

Bride pour montant jusqu'à Ø30

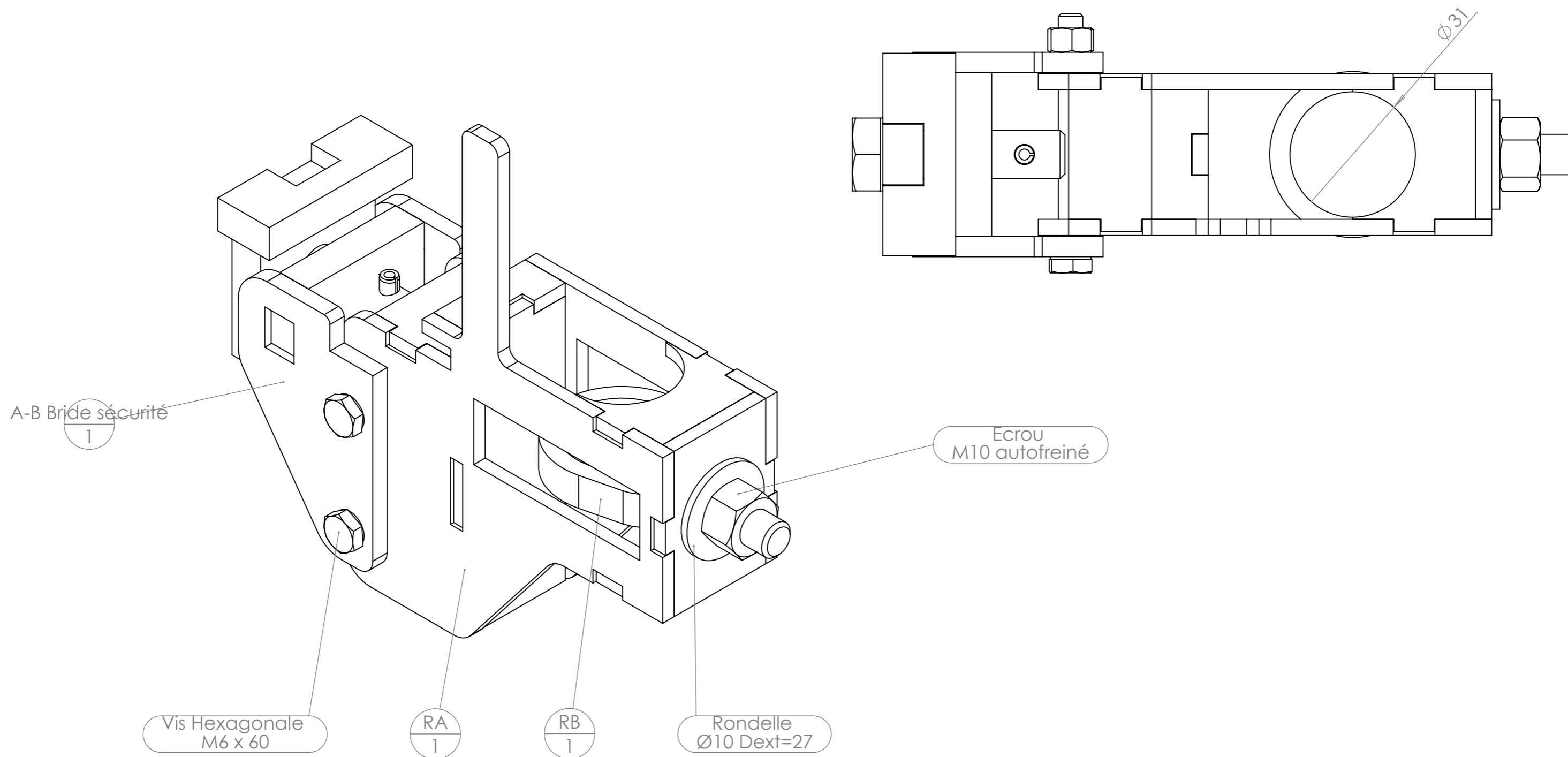

Repère	Désignation	Quantité
A-B Bride sécurité	Bride sécurité	1
RA	Coffret bride rond	1
RB	Serrage bride rond	1
Ecrou	ecrou M6 autofreiné	2
Ecrou	Ecrou M10 autofreiné	1
Vis Hexagonale	Vis hexagonale M6 x 60	2
Rondelle	Rondelle Ø10 série LU	1

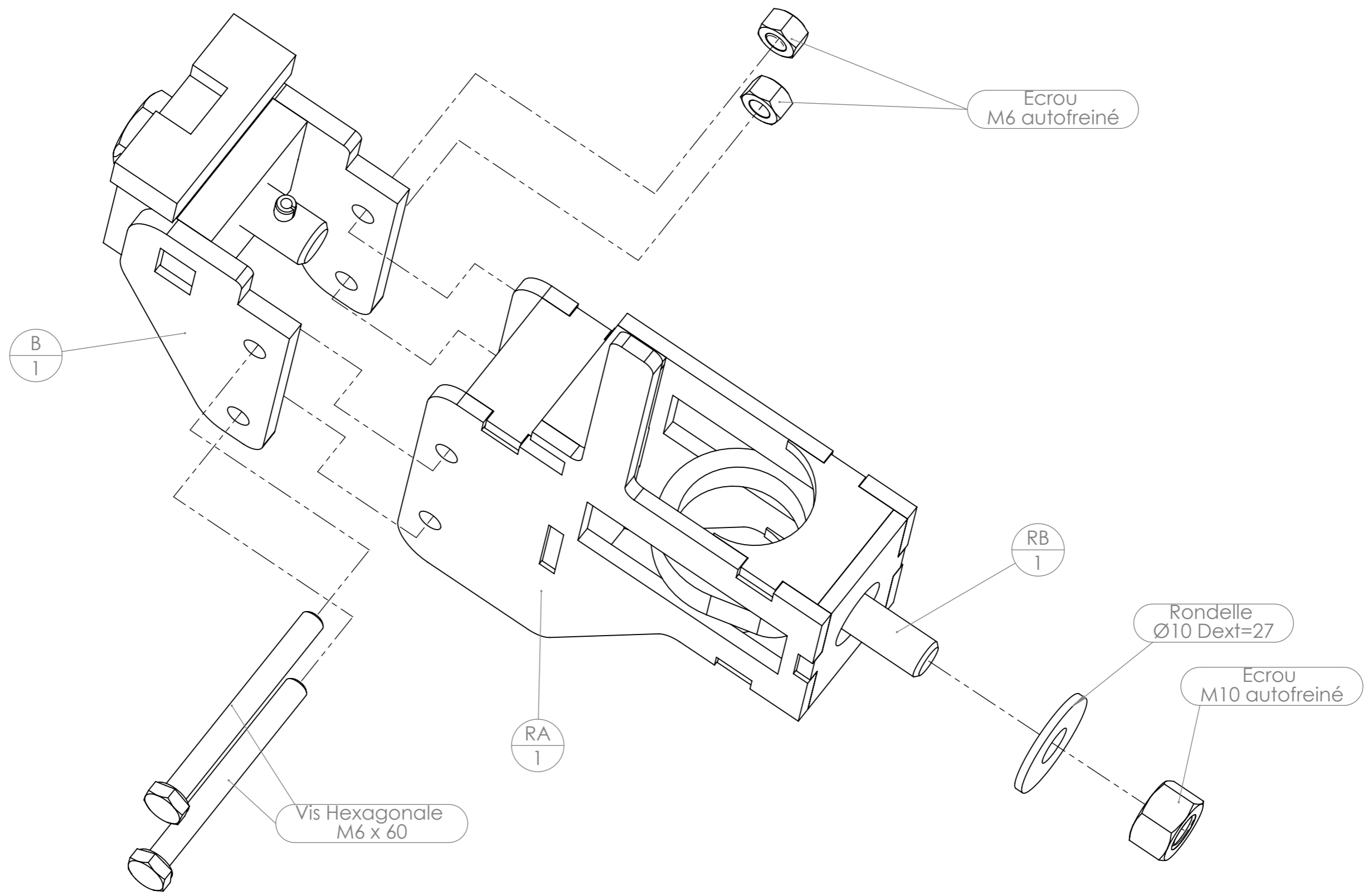

Outil	Bride de sécurité			L'atelier paysan	
Date	06/12/2023	Version	2.1		page n° 1 / 2
Feuille	A-A' - B				

L'assemblage se fait par enboîtement des deux pièces.
Puis soudure bouchon

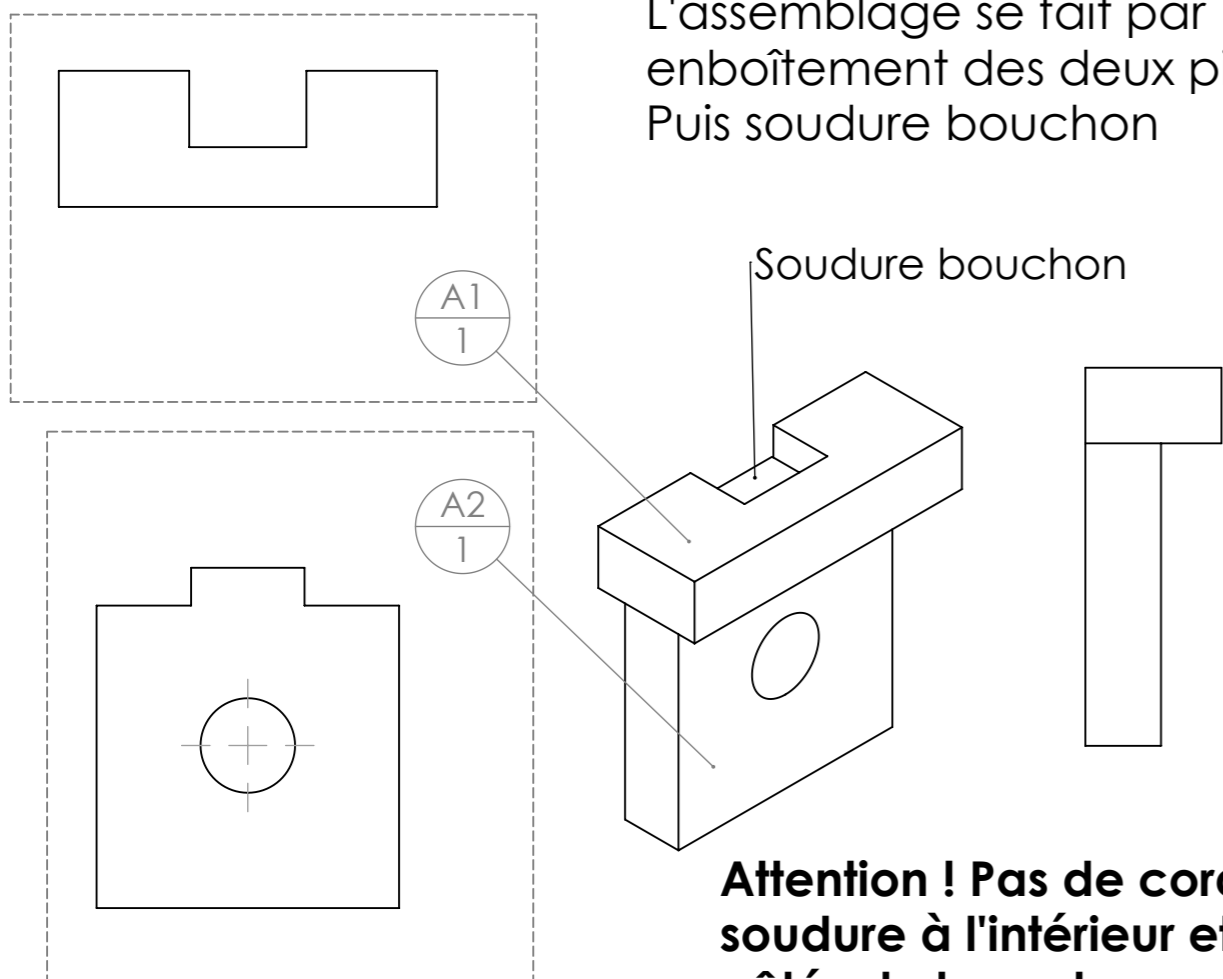

Attention ! Pas de cordons de soudure à l'intérieur et sur les côtés du taquet

repère	Désignation	LONGUEUR	Quantité
A1	A1 taquet bride sécurité basse traction	SPE	1
A2	A2 taquet bride sécurité basse traction	SPE	1

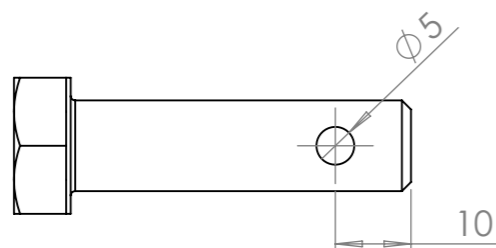

repère	Désignation	P	LONGUEUR	Quantité
A'1	Vis Hexagonale M12 x 45 10.9	1x Ø5 ;	STD	1

L'assemblage se fait par enboîtement des trois pièces.
Puis soudure bouchon

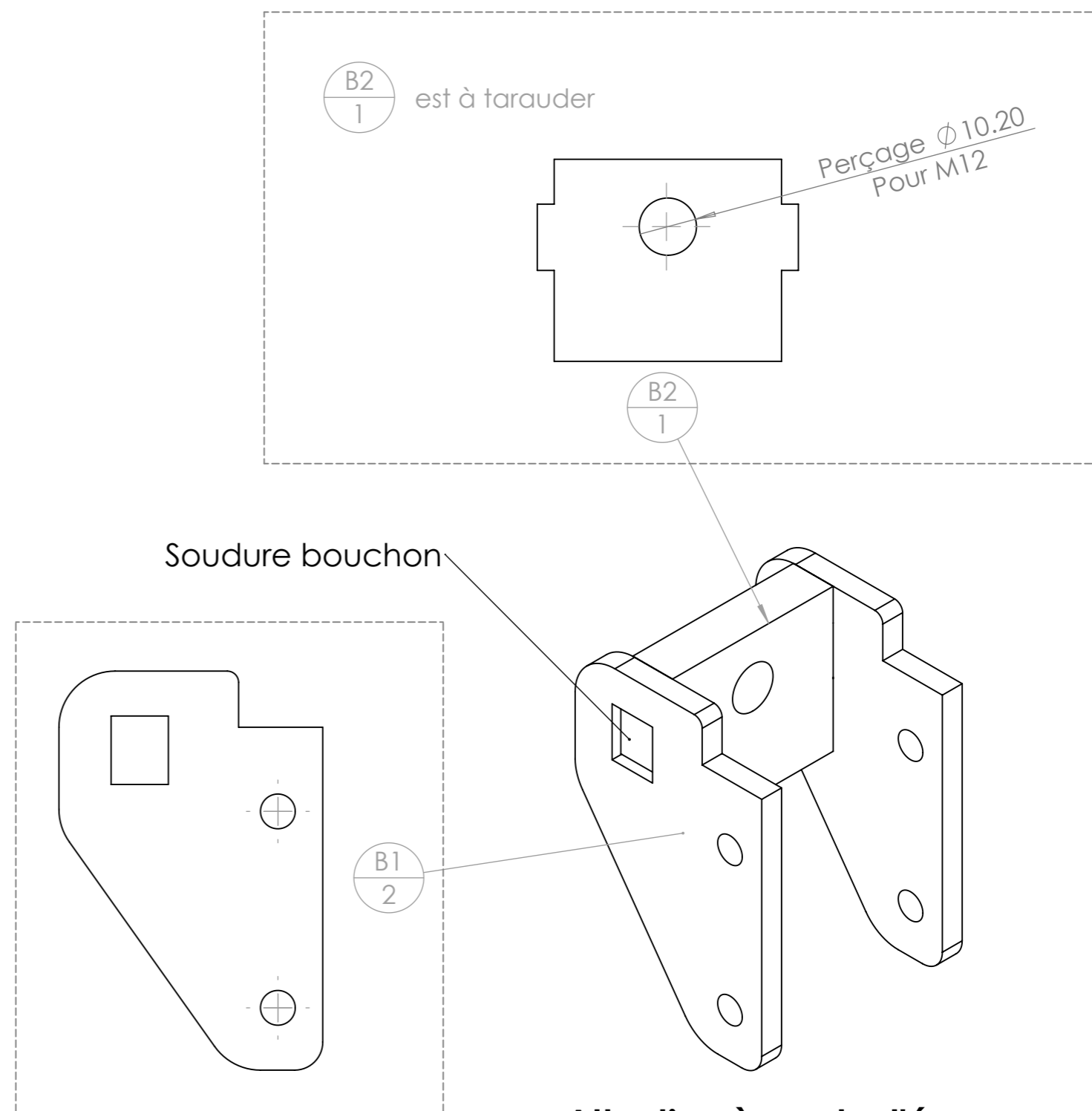

Attention à garder l'équerrage lors de la soudure

repère	Désignation	P	LONGUEUR	Quantité
B1	B1 bride sécurité basse traction		SPE	2
B2	B2 bride sécurité basse traction	M12	SPE	1

La goupille élastique vient s'insérer dans le perçage de la vis

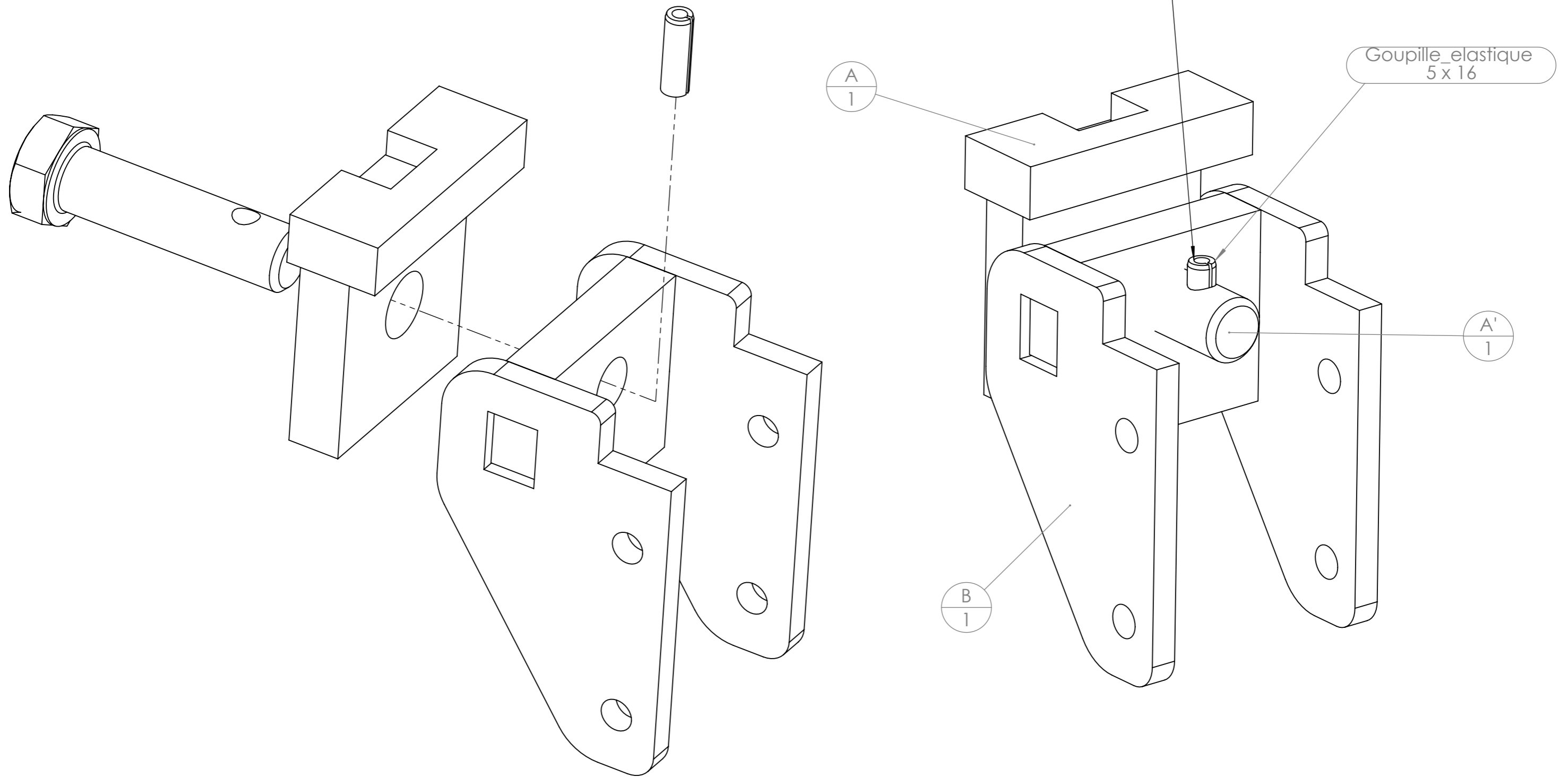

La goupille élastique permet le desserrage sans risquer d'enlever le taquet de la bride

Repère	Désignation	Quantité
A	Taquet bride	1
B	Coffret de sécurité	1
A'	Vis pour goupille élastique	1
Goupille_elastique	Goupille élastique 5 x 16	1

Outil	RB			L'atelier paysan	
Date	24/11/2023	Version	2.0		page n° 1 / 1
Feuille	RB				

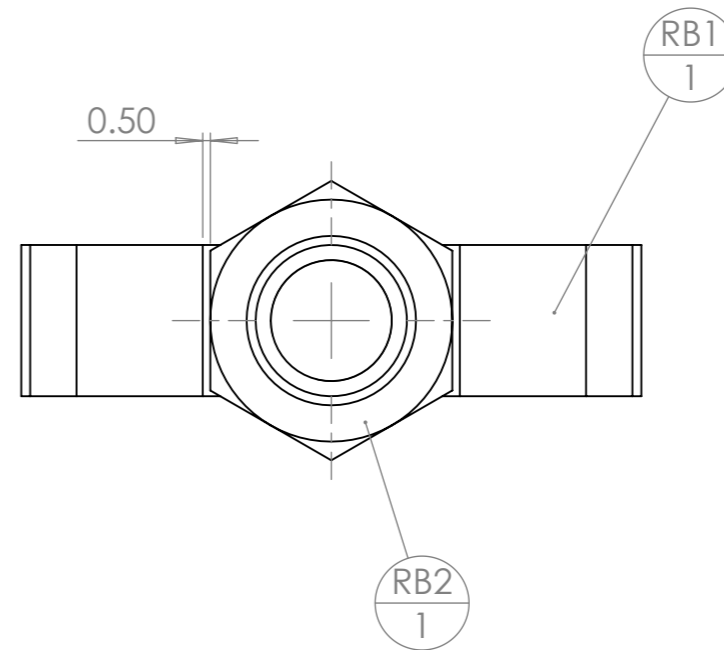
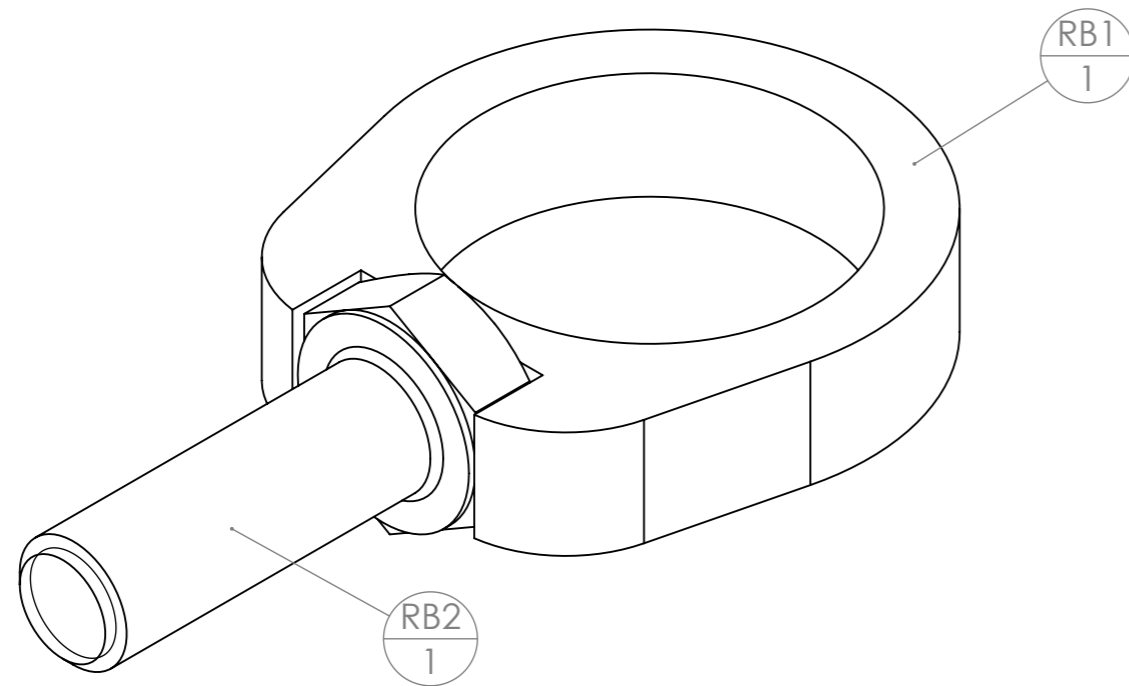

repère	Désignation	ANGLE1	ANGLE2	P	LONGUEUR	Quantité
RB1	RB1 serrage bride rond outils basse traction				SPE	1
RB2	Vis Hexagonale M10 x 30				STD	1

Ordre d'assemblage :

- Emboiter les pièces lasers
- Faire des soudures bouchon comme indiqué

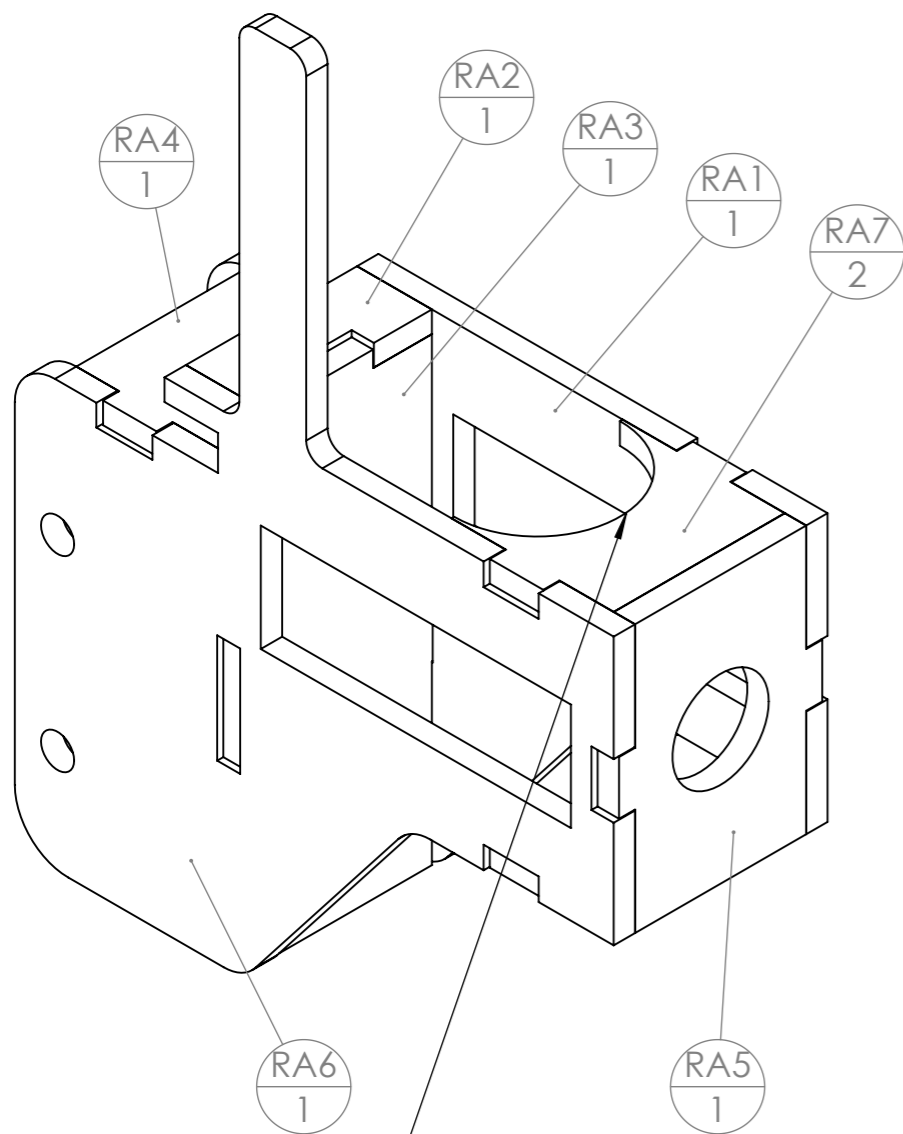

Veiller à aligner les deux demi-cercles en utilisant un tube de 30 et ne pas faire de soudure sur la zone mince des demi-cercles

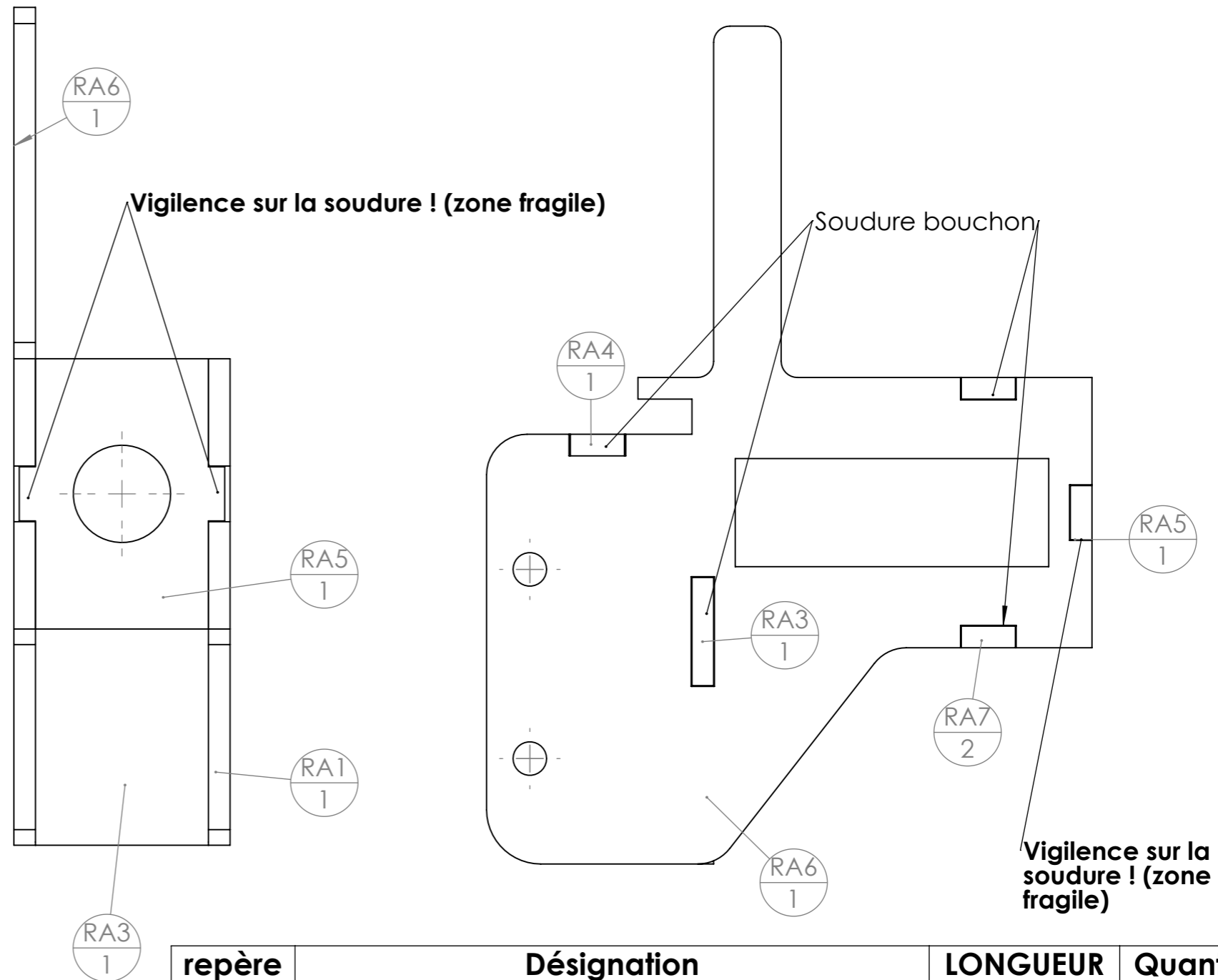

repère	Désignation	LONGUEUR	Quantité
RA1	RA1 bride rond basse traction	SPE	1
RA2	Pièce 2 commune bride basse traction	SPE	1
RA3	Pièce 3 commune bride basse traction	SPE	1
RA4	Pièce 4 commune bride basse traction	SPE	1
RA5	RA5 bride rond basse traction	SPE	1
RA6	RA6 bride rond basse traction	SPE	1
RA7	RA7 bride rond basse traction	SPE	2

Outil	Bride fixe rond 30				
Date	06/12/2023	Version	2.0		page n° 4 / 4
Feuille	Fournitures globales				

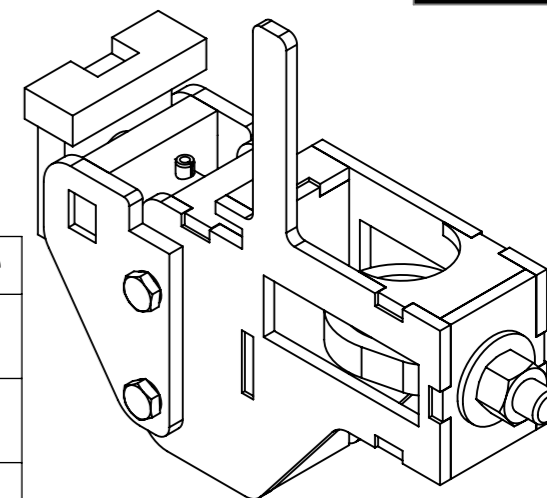

repère	Désignation	ANGLE1	ANGLE2	P	LONGUEUR	Quantité
A1	A1 taquet bride sécurité basse traction				SPE	1
A2	A2 taquet bride sécurité basse traction				SPE	1
B1	B1 bride sécurité basse traction				SPE	2
B2	B2 bride sécurité basse traction			M12	SPE	1
A'1	Vis Hexagonale M12 x 45 10.9			1x Ø5 ;	STD	1
Goupille_elastique	Goupille élastique 5 x 16				STD	1
RA2	Pièce 2 commune bride basse traction				SPE	1
RA3	Pièce 3 commune bride basse traction				SPE	1
RA4	Pièce 4 commune bride basse traction				SPE	1
RB1	RB1 serrage bride rond outils basse traction				SPE	1
RB2	Vis Hexagonale M10 x 30				STD	1
Ecrou	ecrou M6 autofreiné				STD	2
Vis Hexagonale	Vis hexagonale M6 x 60				STD	2
Rondelle	Rondelle Ø10 série LU				STD	1
Ecrou	Ecrou M10 autofreiné				STD	1
RA1	RA1 bride rond basse traction				SPE	1
RA5	RA5 bride rond basse traction				SPE	1
RA7	RA7 bride rond basse traction				SPE	2
RA6	RA6 bride rond basse traction				SPE	1

Outil	Pièces sous-traitées communes brides			
Date	06/12/2023	Version	page n° 1 / 3	
Feuille	Pièce 2			

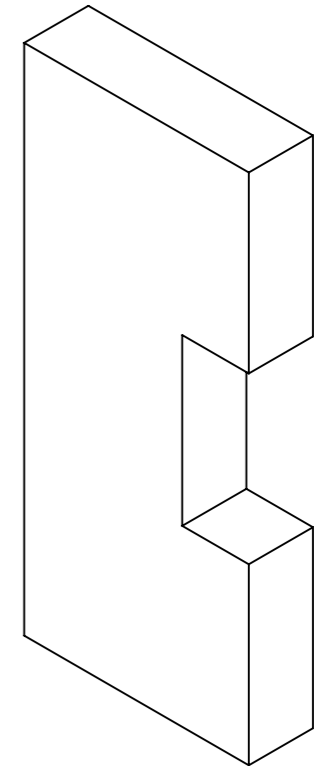
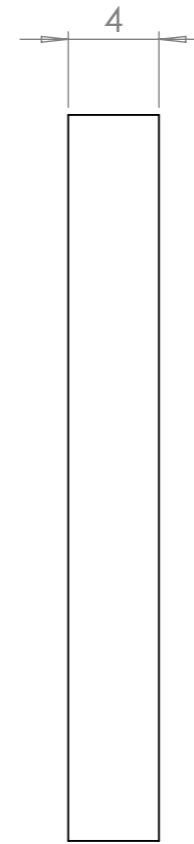
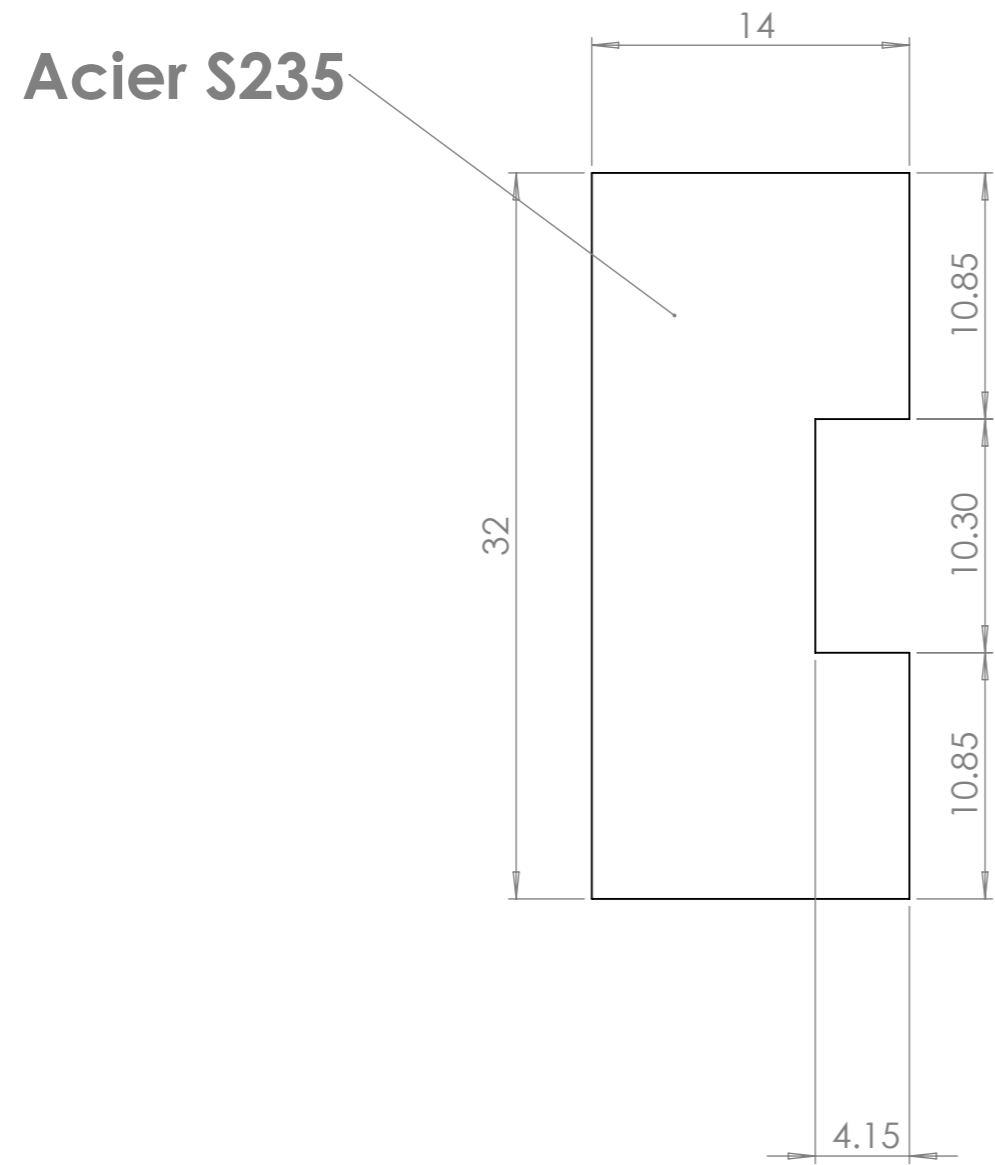

Outil	Pièces sous-traitées communes brides			
Date	06/12/2023	Version	page n° 2 / 3	
Feuille	Pièce 3			



Acier S235

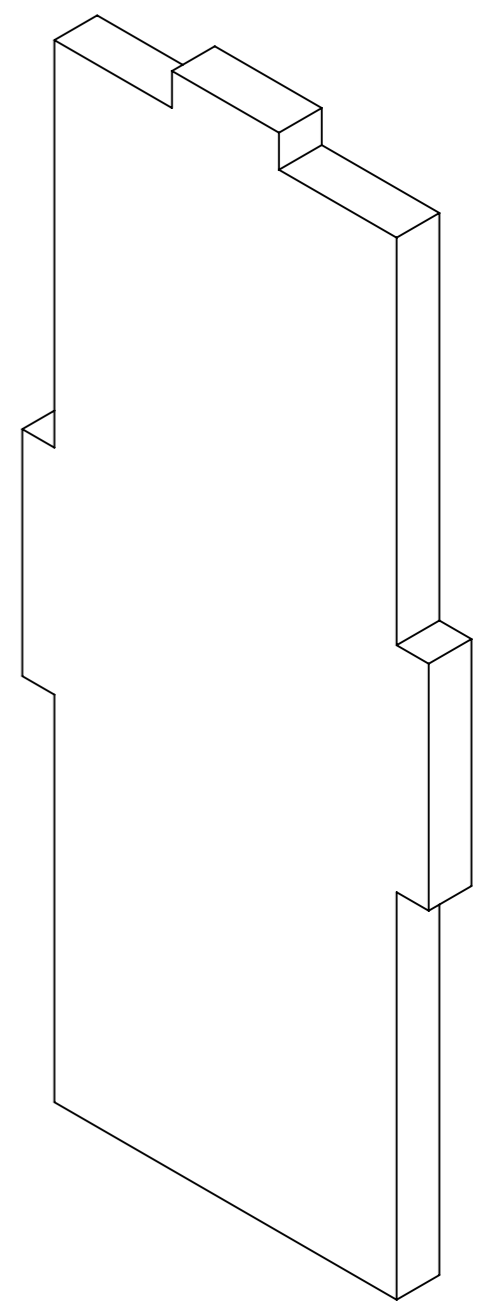
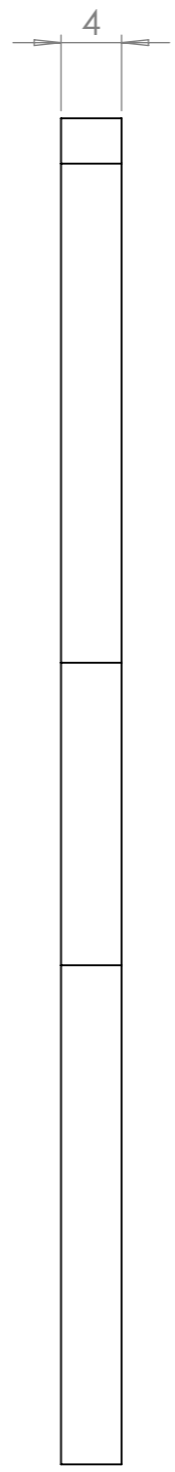
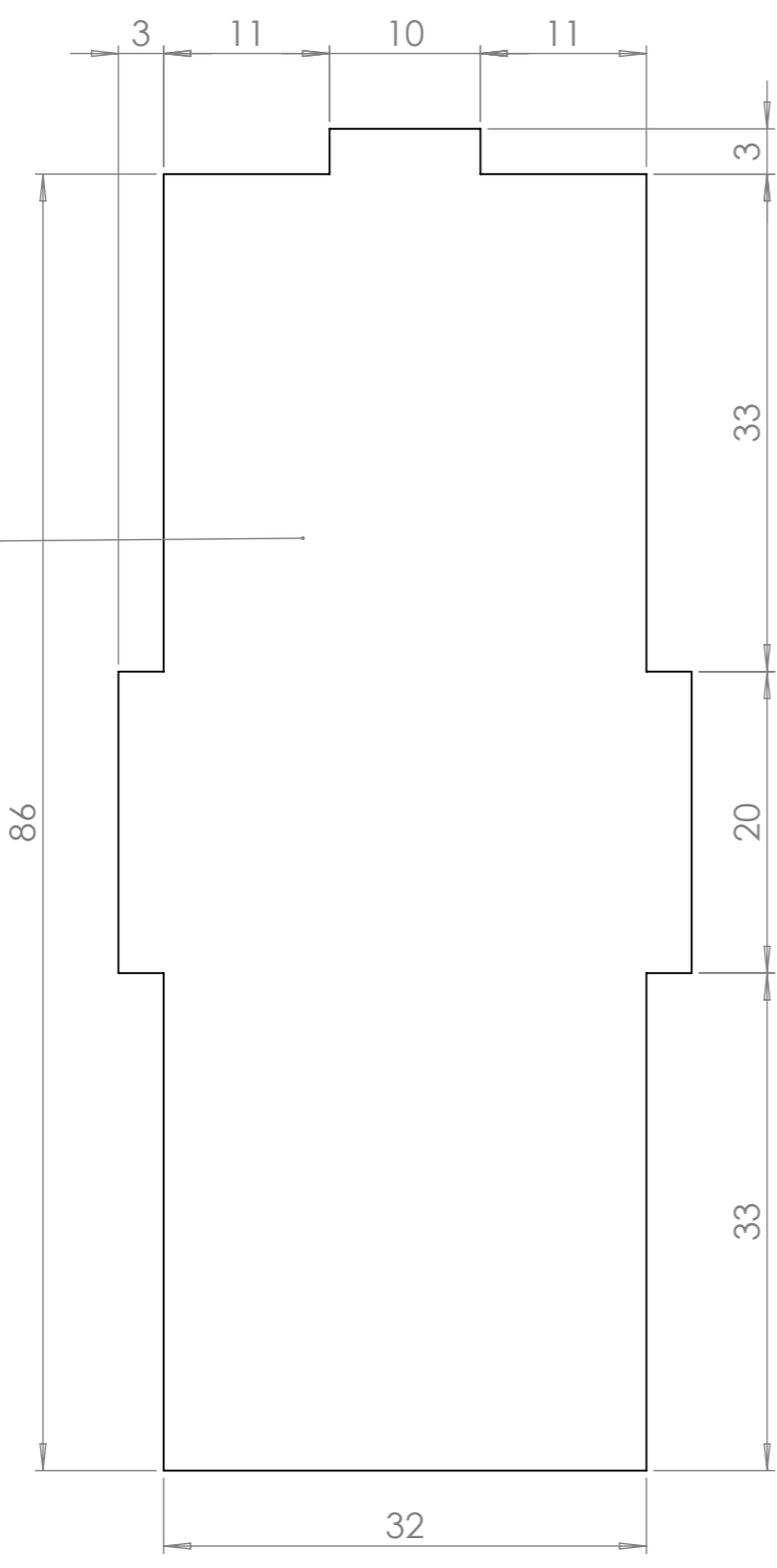

Outil	Pièces sous-traitées communes brides			L'atelier paysan
Date	06/12/2023	Version	page n° 3 / 3	
Feuille	Pièce 4			

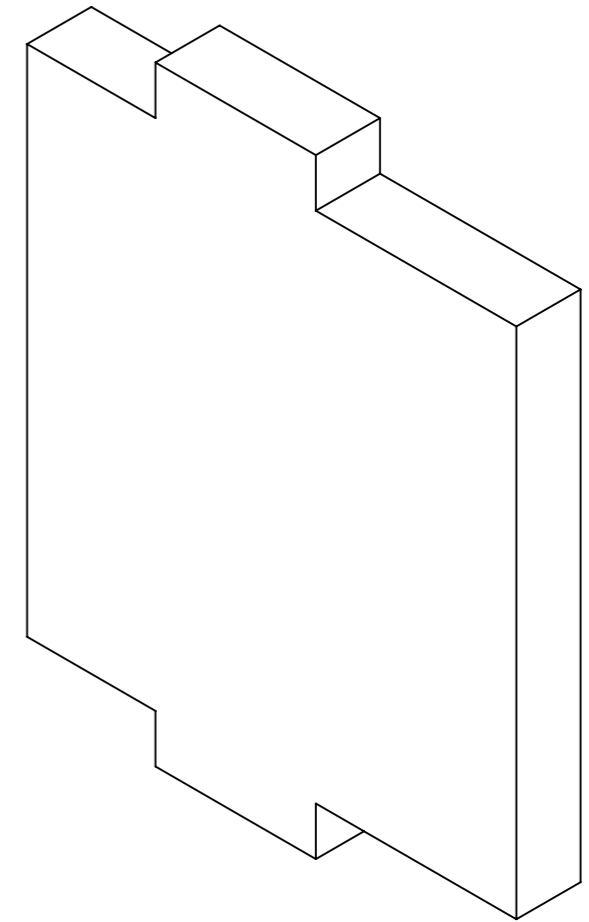
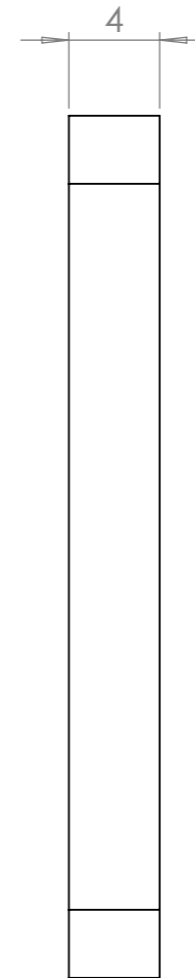
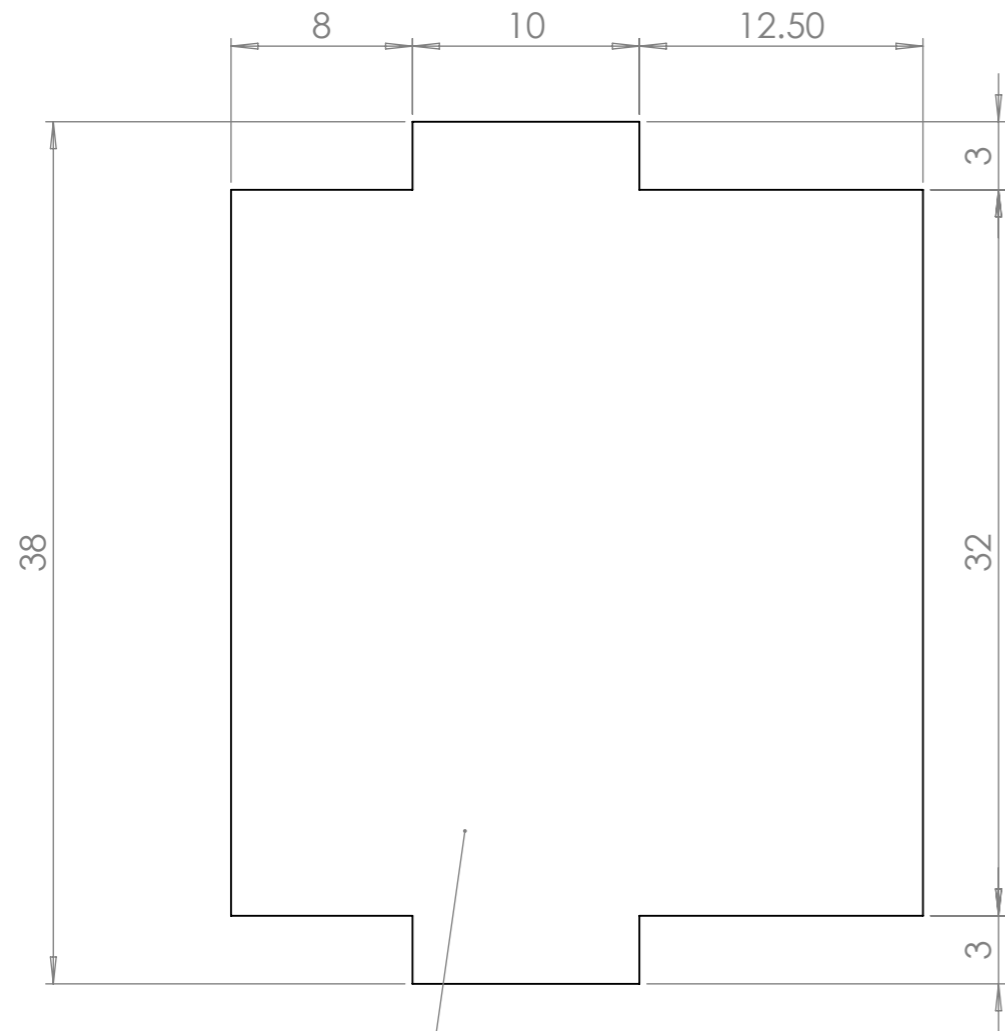

Acier S235

Outil	Pièces sous-traitées Bride rond 30			L'atelier paysan	
Date	06/12/2023	Version	2.0		page n° 1 / 4
Feuille	RA1				

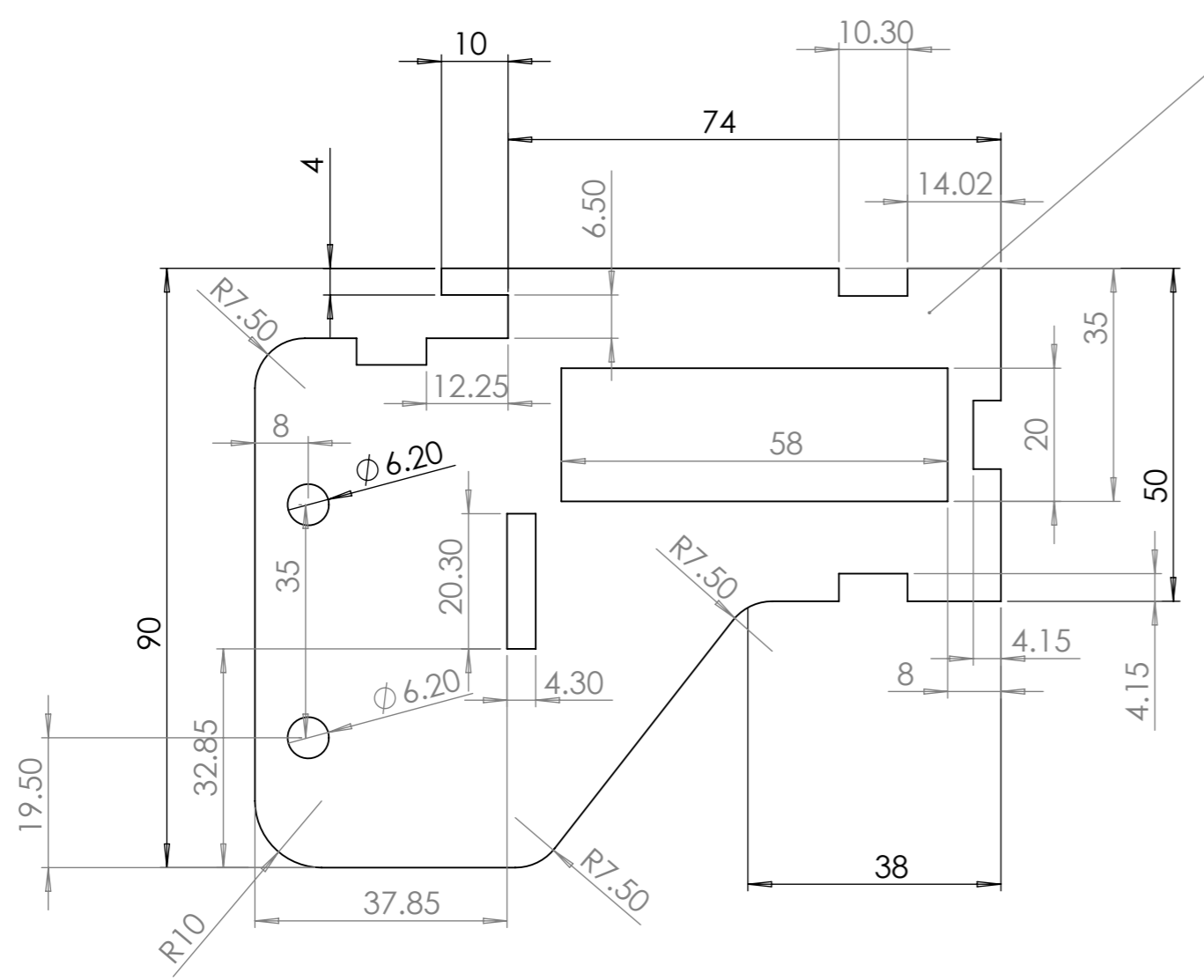

RA1

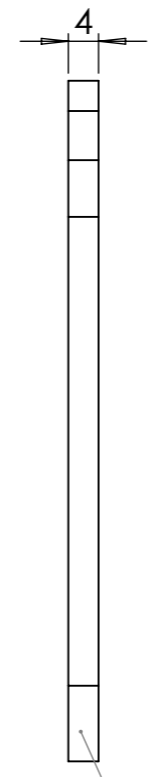

Acier S235

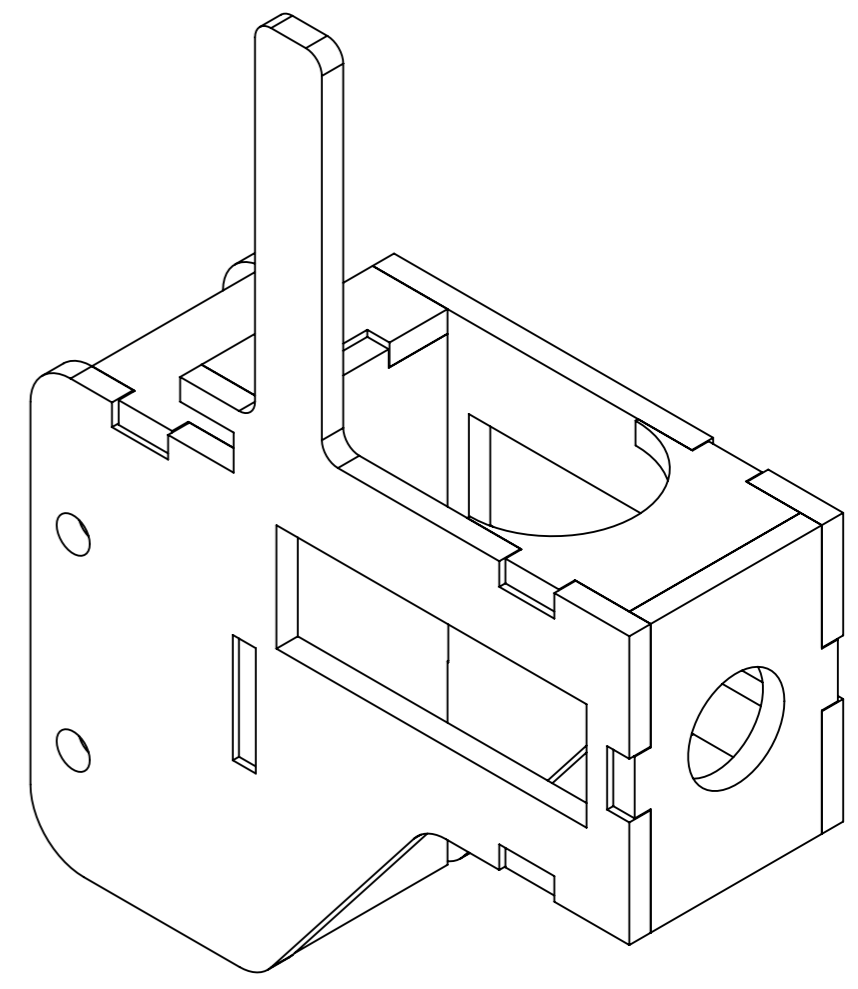

Outil	Pièces sous-traitées Bride rond 30				
Date	06/12/2023	Version	2.0		page n° 2 / 4
Feuille	RA5				

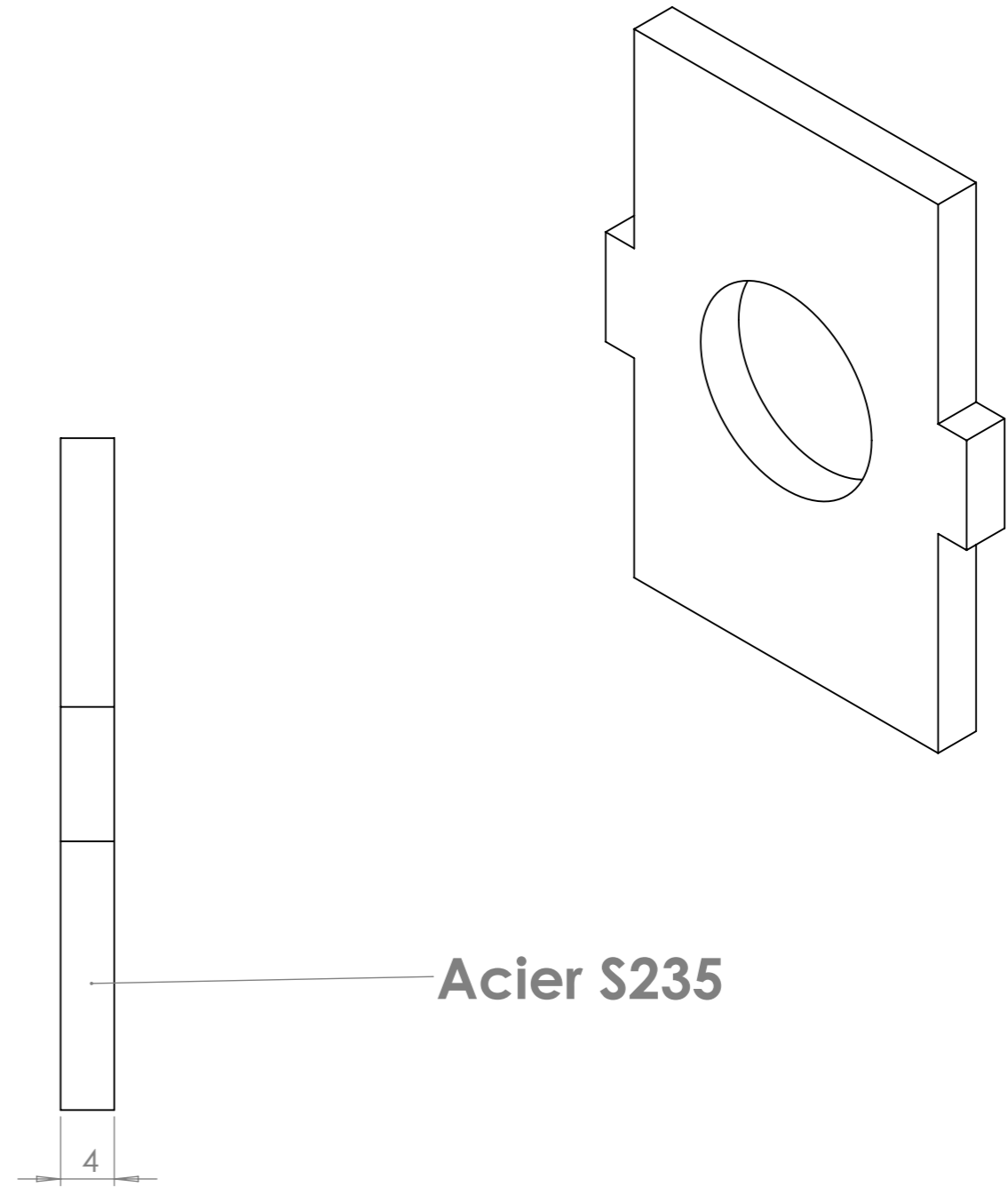
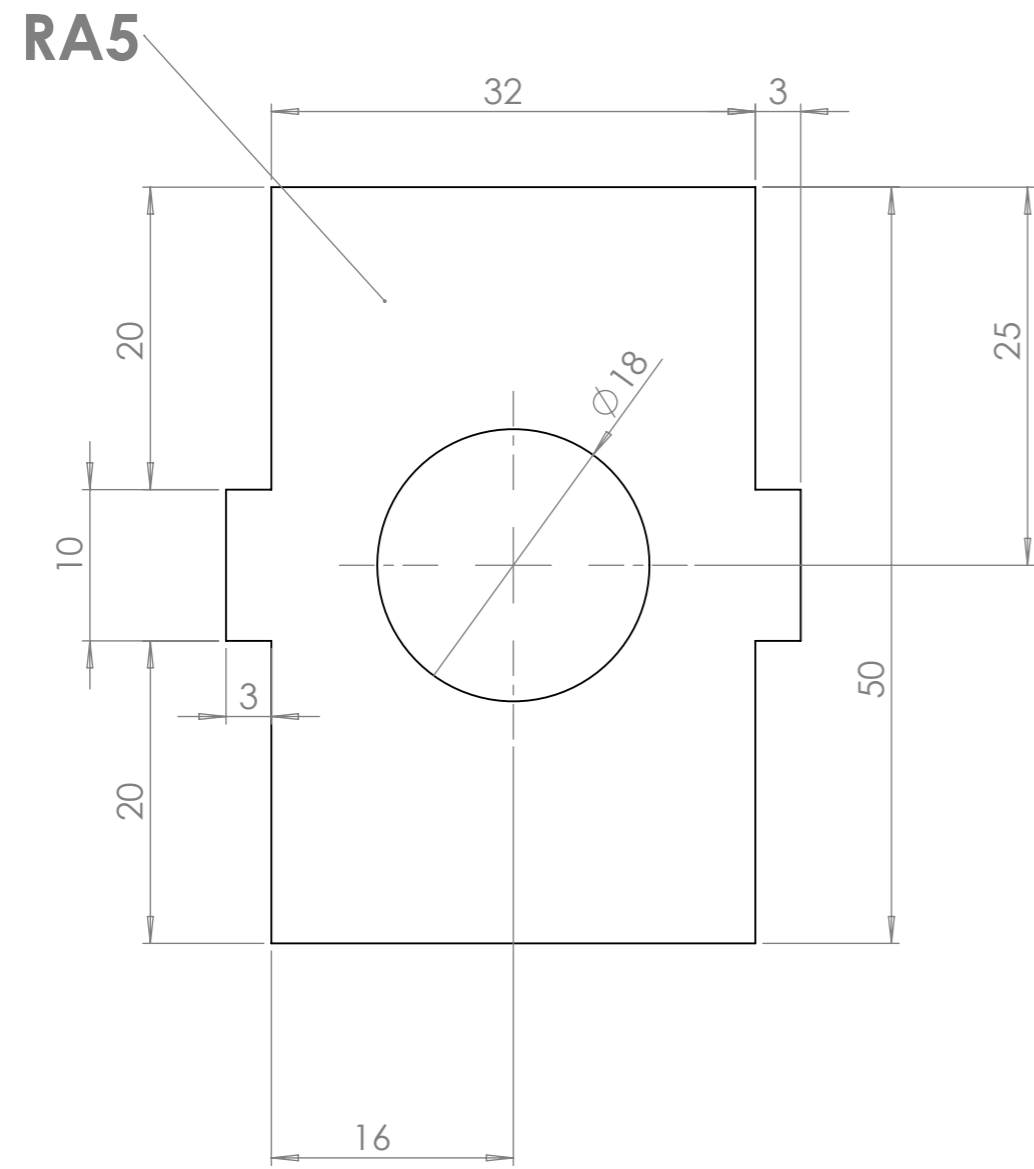

Outil	Pièces sous-traitées Bride rond 30				
Date	06/12/2023	Version	2.0		page n° 3 / 4
Feuille	RA6				

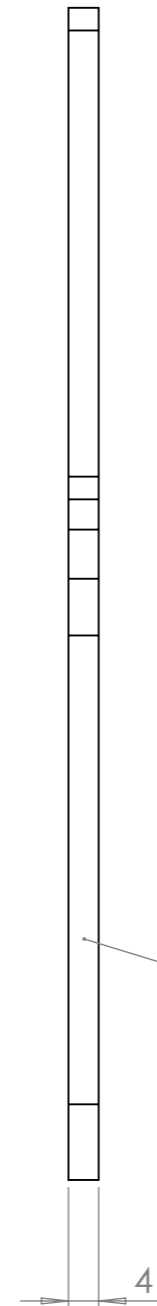
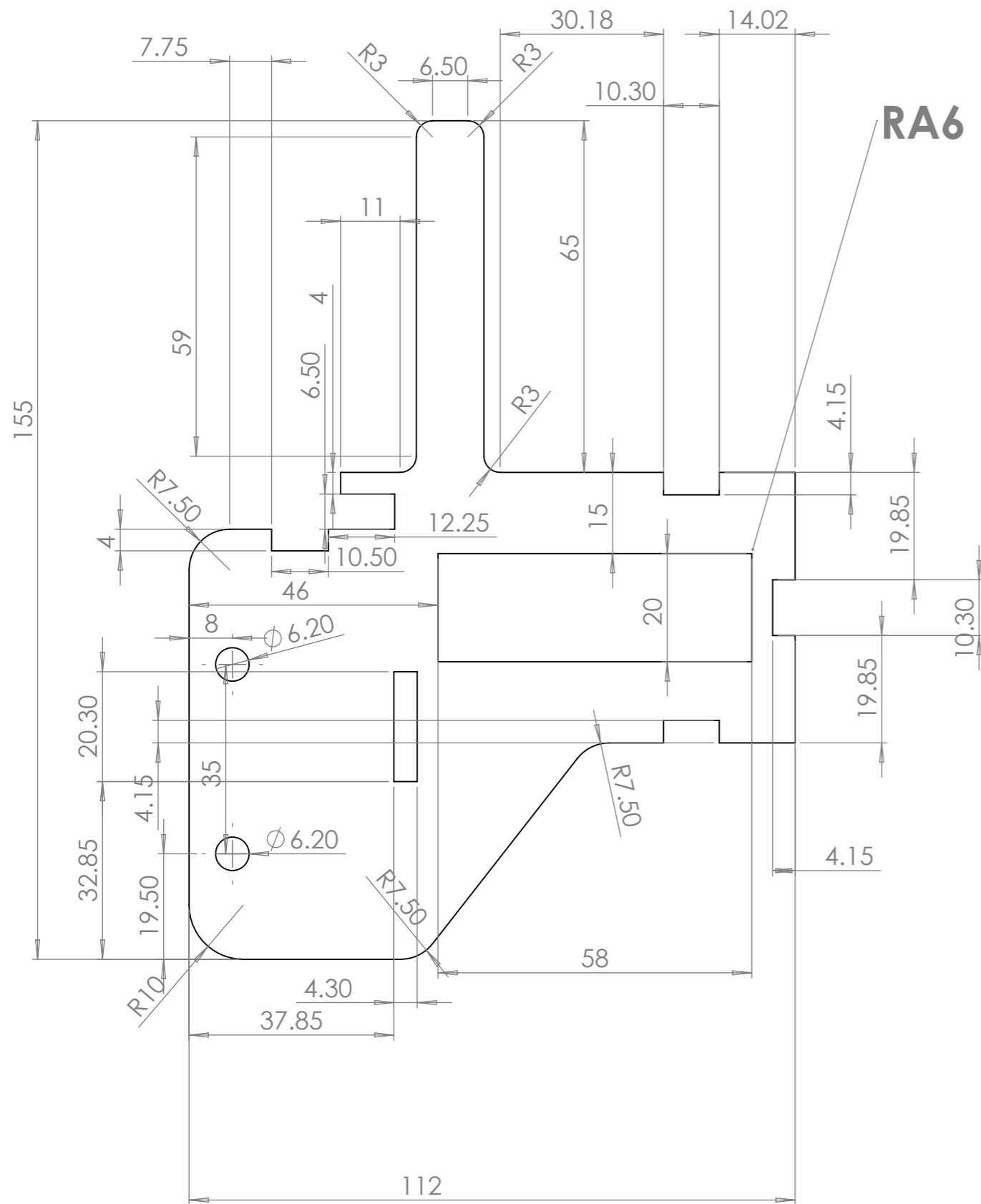

Acier S235

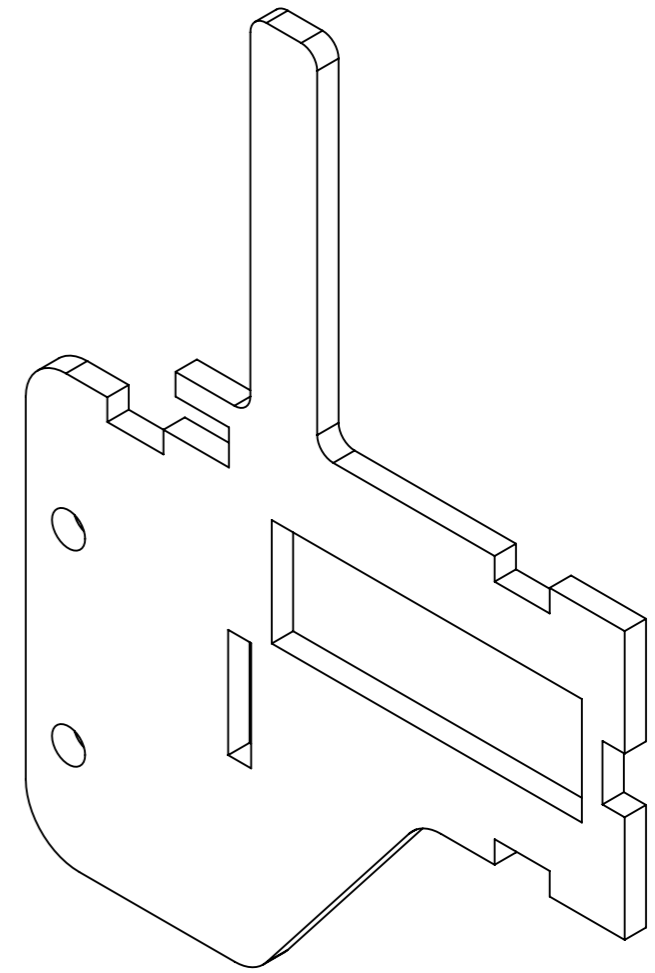

Outil	Pièces sous-traitées Bride rond 30			L'atelier paysan	
Date	06/12/2023	Version	2.0		page n° 4 / 4
Feuille	RA7				

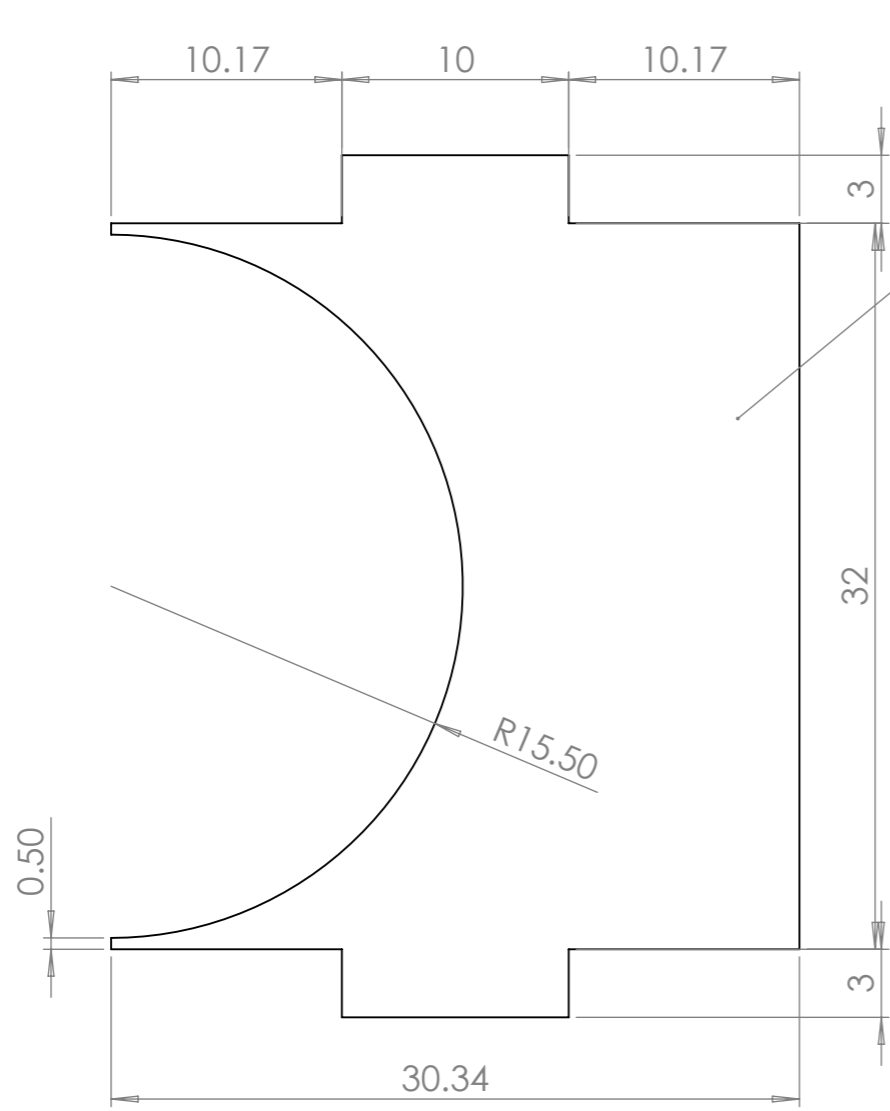

RA7

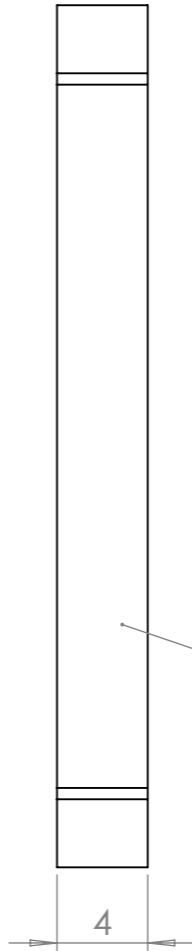

Acier S235

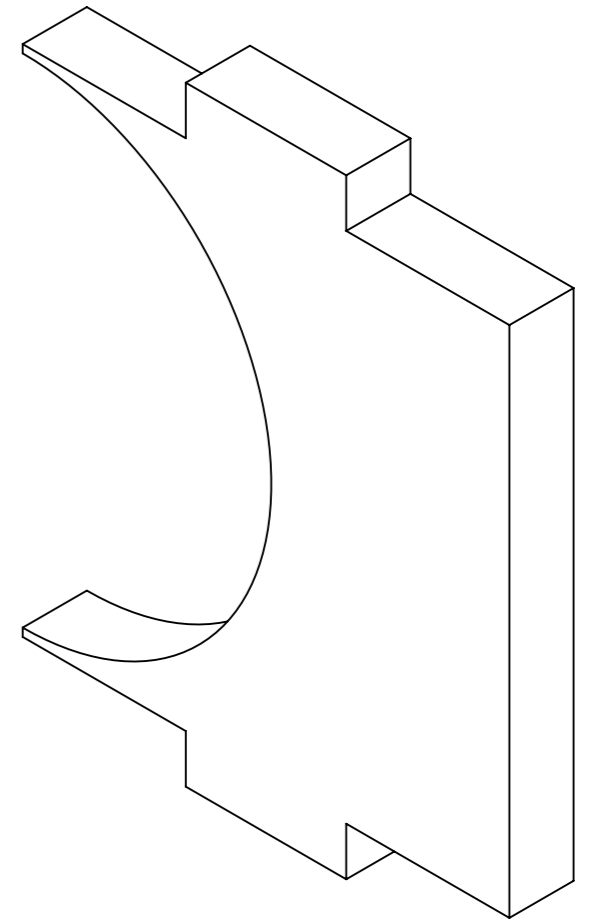

Outil	Pièces sous-traitées Bride de sécurité		
Date	06/12/2023	Version	2.1
Feuille	A1		



A1

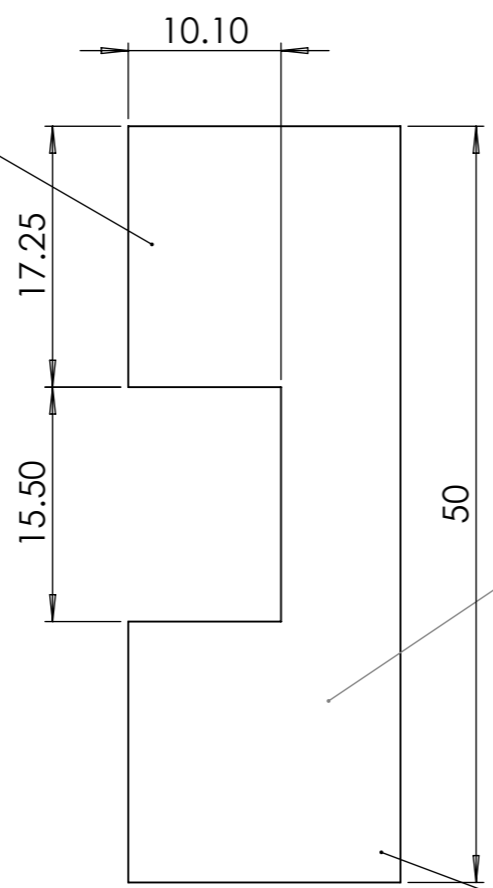

Acier S235

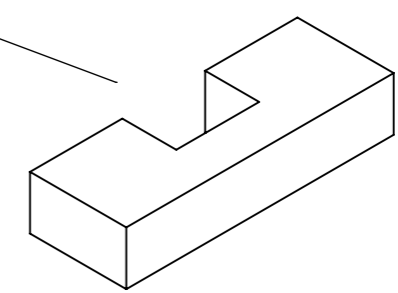
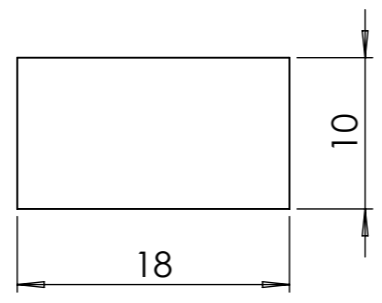

Outil	Pièces sous-traitées Bride de sécurité			
Date	06/12/2023	Version	2.1	
Feuille	A2			



A2

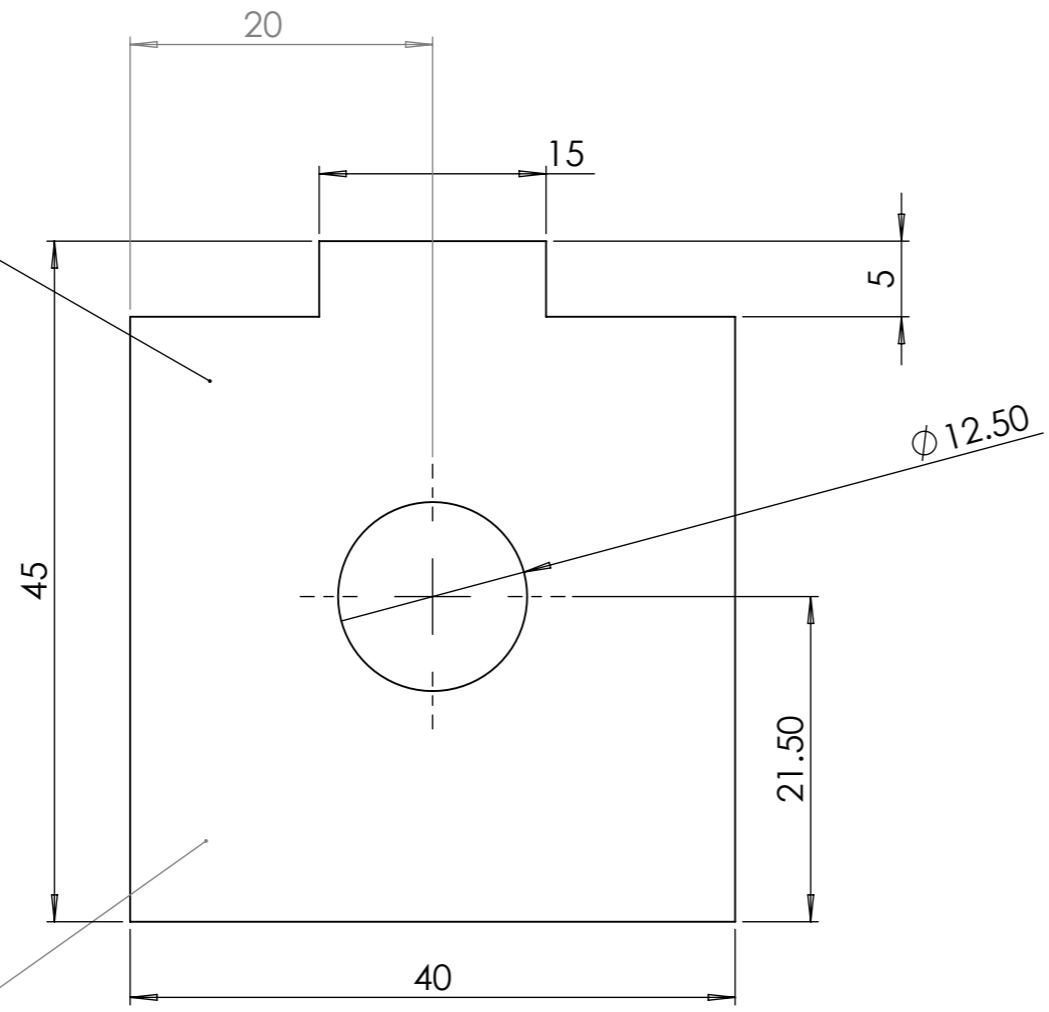

Acier S235

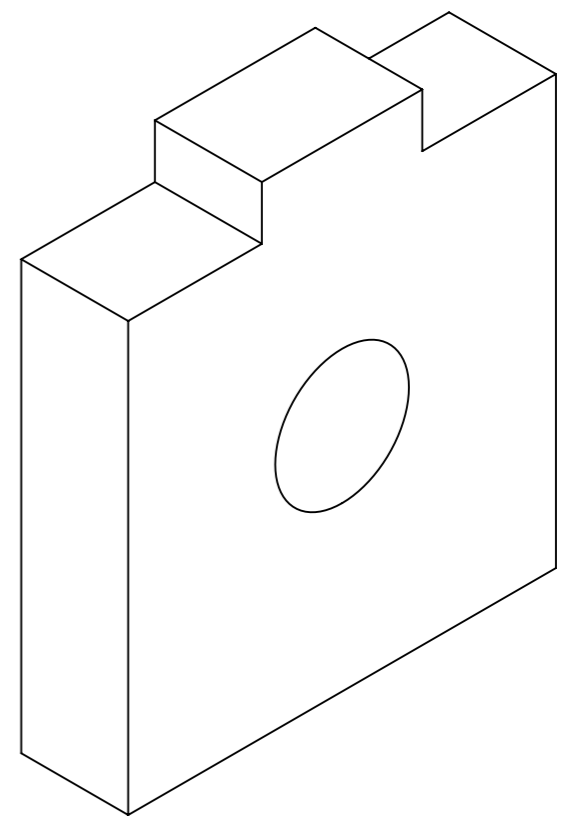
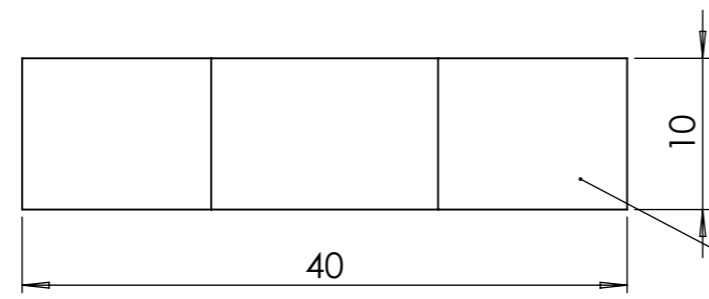

Outil	Pièces sous-traitées Bride de sécurité		
Date	06/12/2023	Version	2.1
Feuille	B1		

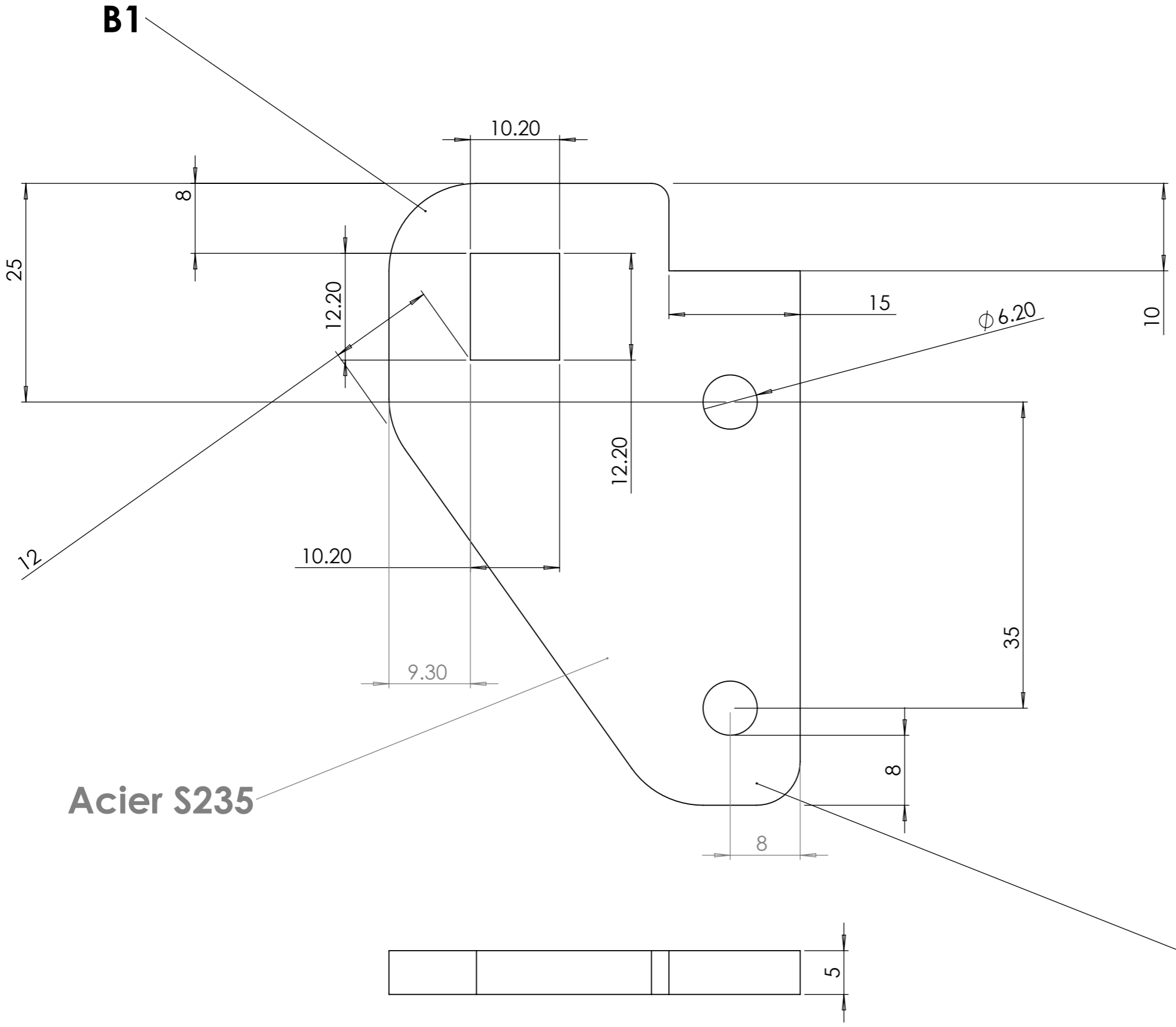

Acier S235

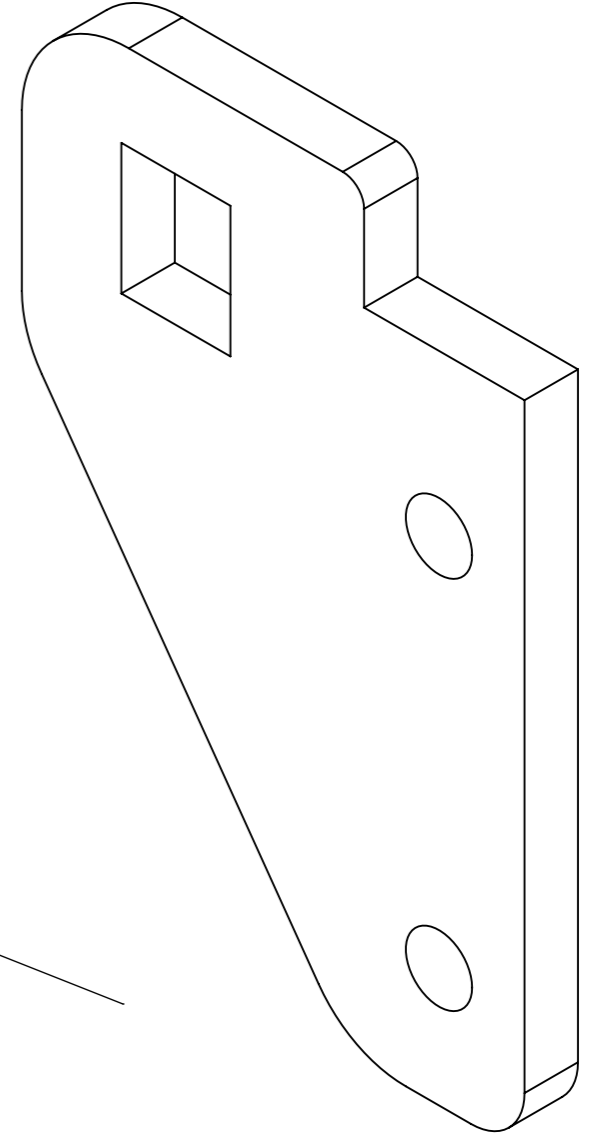

Outil	Pièces sous-traitées Bride de sécurité			
Date	06/12/2023	Version	2.1	
Feuille	B2			



B2

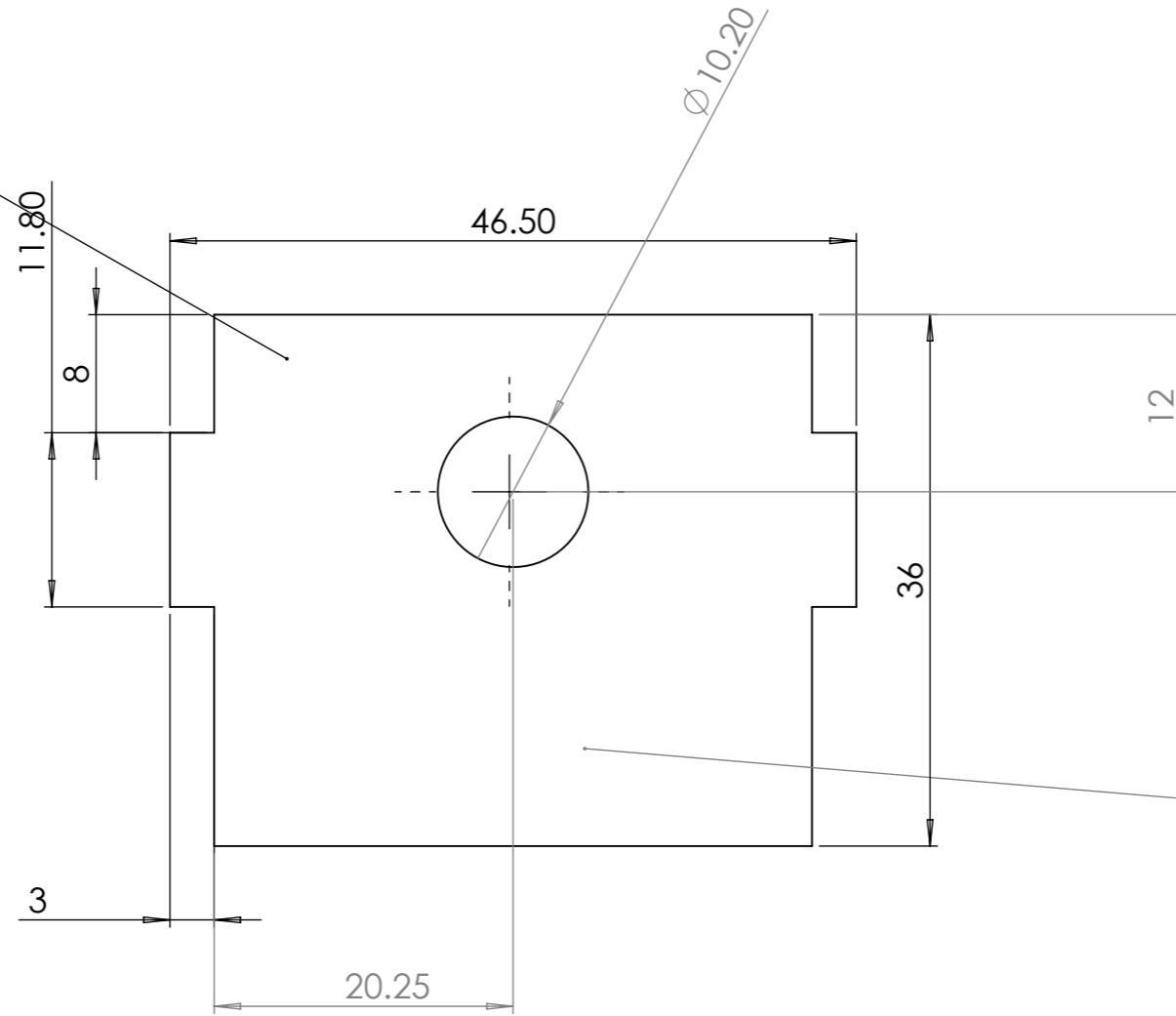

Acier S235

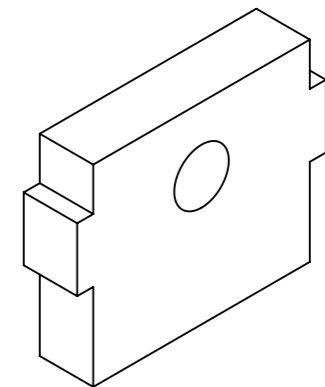

Outil	RB1		
Date	17/11/2023	Version	2.0
Feuille	RB1		

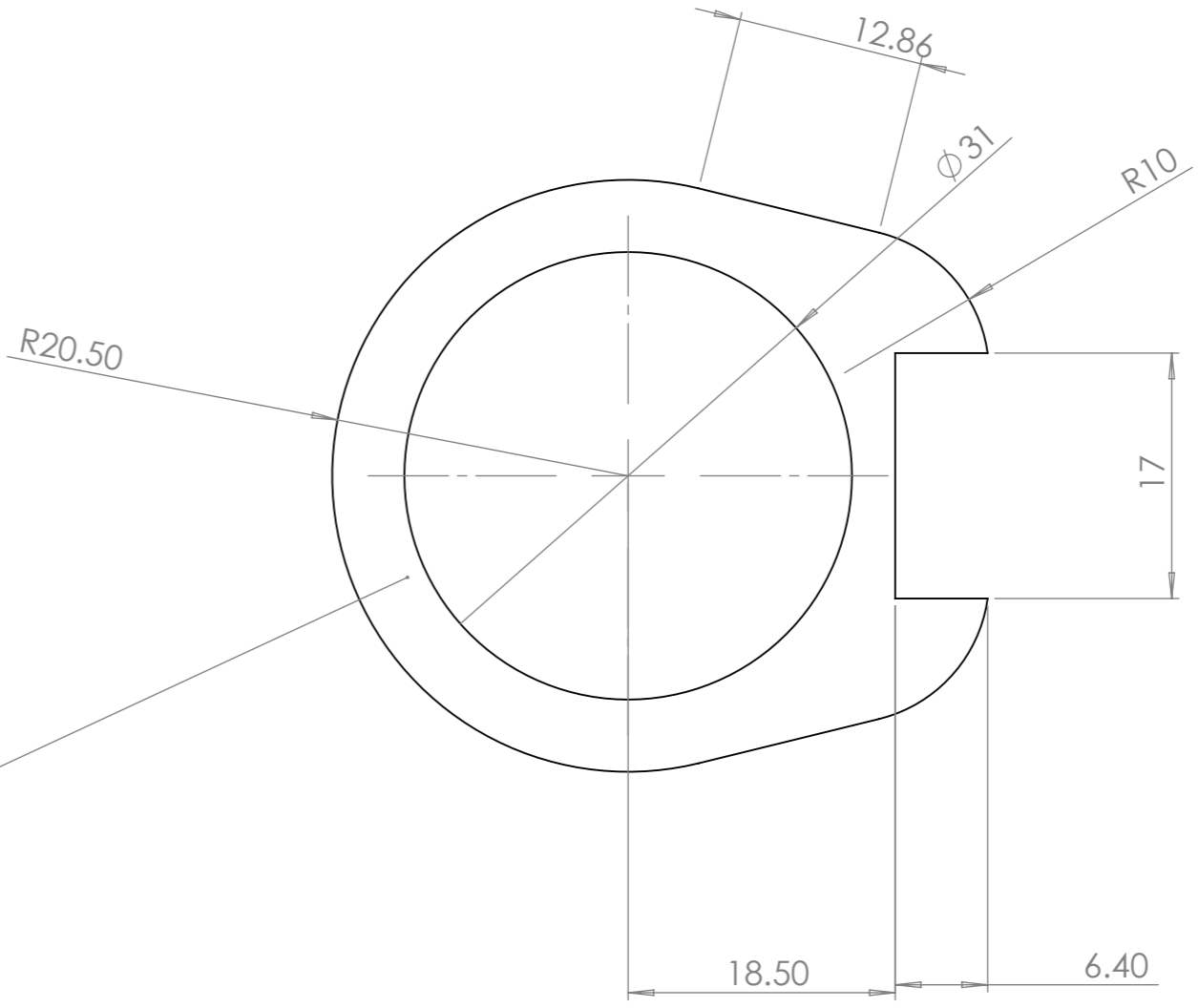

Acier S235

