

roue monokit serre

Repère	Désignation	Quantité
A		1
B		1
roue monokit serre	Roue brouette 400x100 axe 20 mm	1

Outil	Monokit			
Date	03/07/2023	Version	page n° 2 / 9	
Feuille	Encombrement			

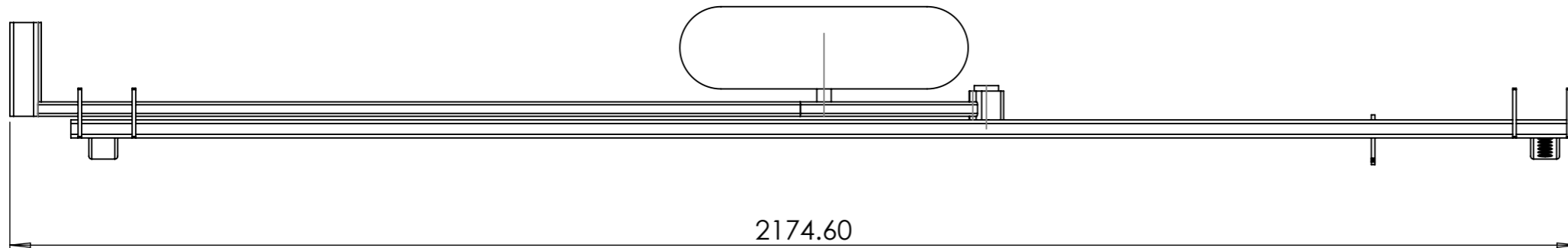

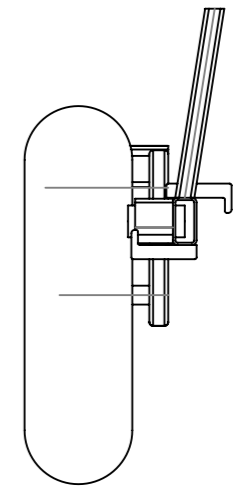
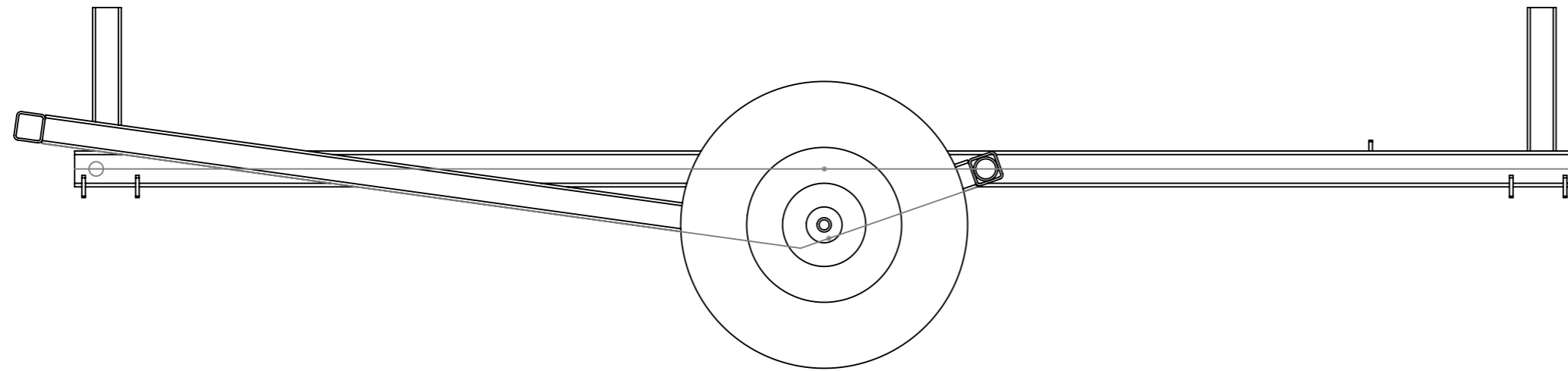
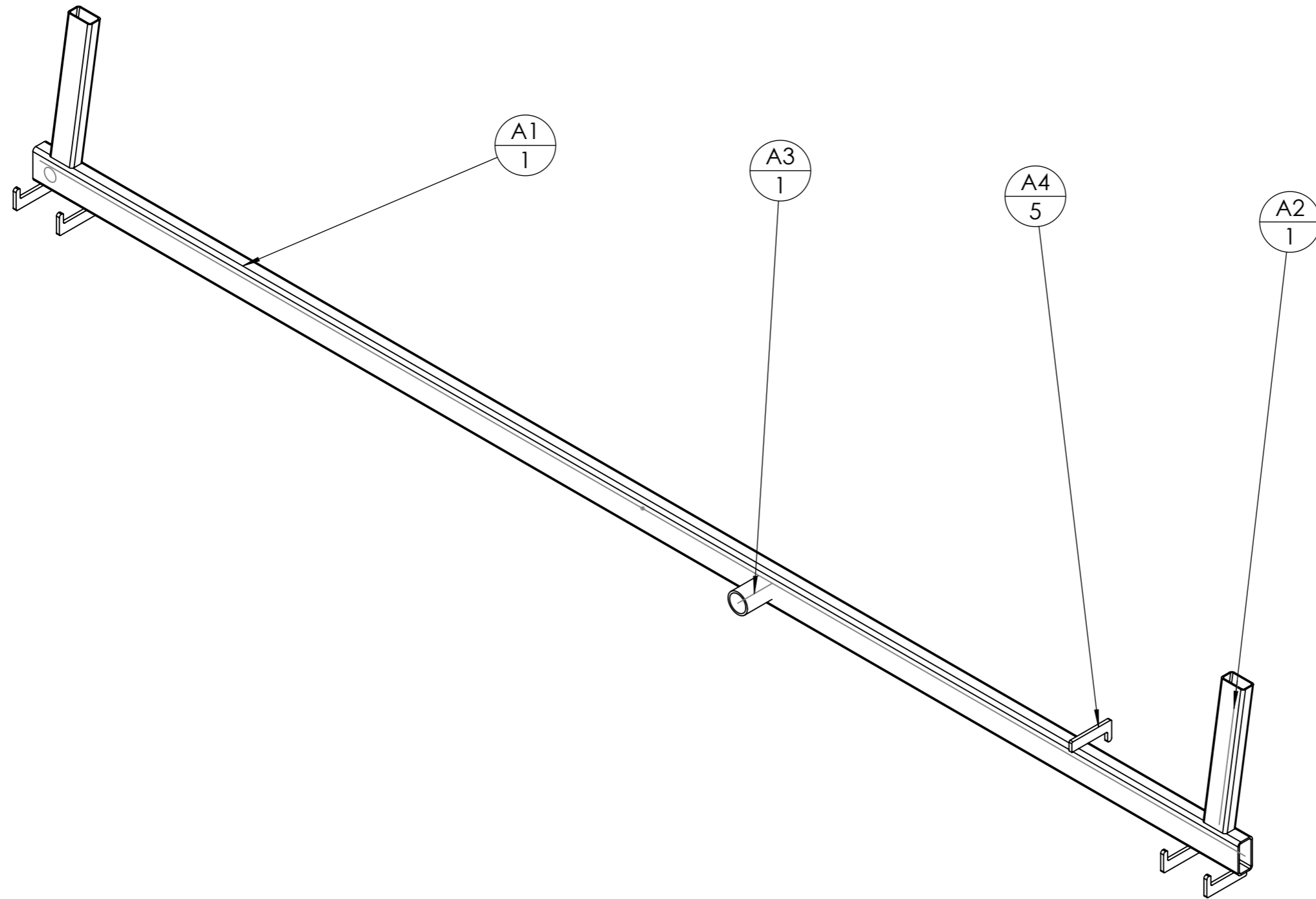

repère	Désignation	ANGLE1	ANGLE2	p	LONGUEUR	Quantité
A1	tube rectangulaire 50 x 25 x 2.5	0°	0°		2090	1
A2	tube rectangulaire 40 x 20 x 2	9°	9°	6 percages d20	205.6607	1
A3	tube rond 33.7 x 2.9	0°	0°		60	1
A4					SPE	5
A	tube rectangulaire 40 x 20 x 2	9°	9°		205.6607	1

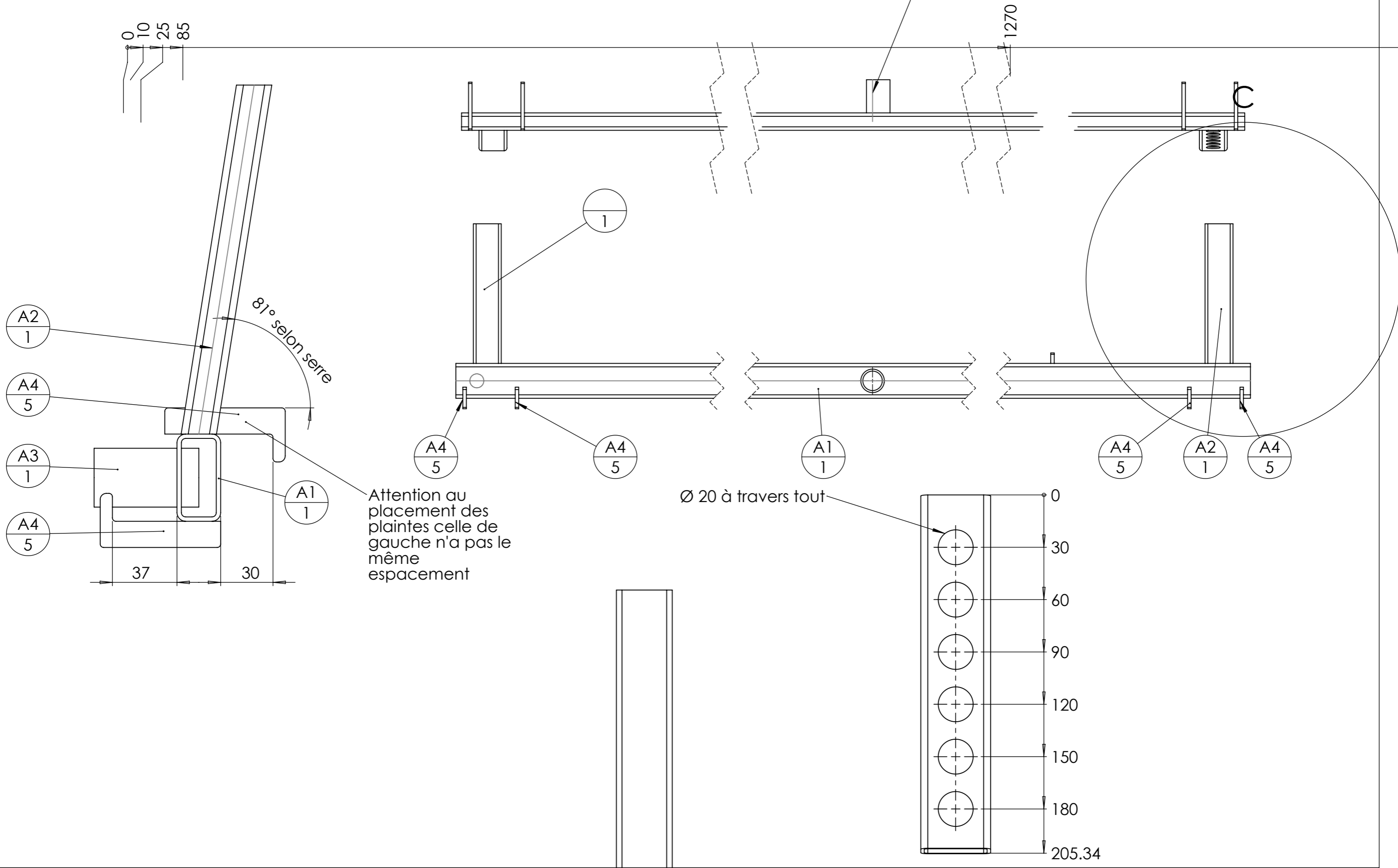

Outil	Monokit			
Date	03/07/2023	Version	page n° 5 / 9	
Feuille	B-Vue générale			

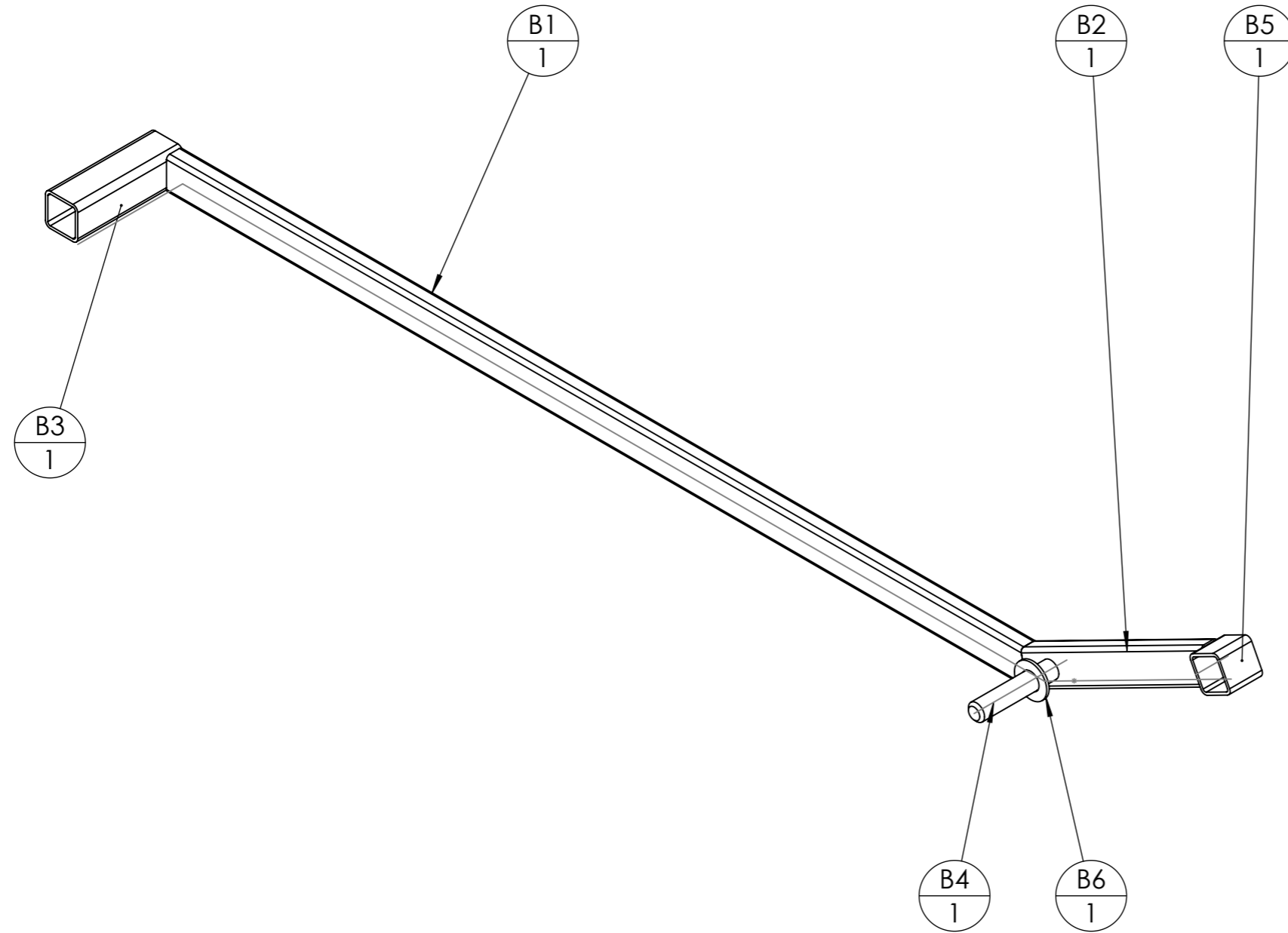

repère	Désignation	ANGLE1	ANGLE2	p	LONGUEUR	Quantité
B1	tube rectangulaire 40 x 20 x 2	13.50	0.00		1067.9	1
B2	tube rectangulaire 40 x 20 x 2	0.00	13.50	20	260	1
B3	tube carré 40 x 3	0.00	0.00		130	1
B4	étiré rond Ø20	0.00	0.00		115	1
B5	tube carré 40 x 3	0.00	0.00		40	1
B6	Rondelle Ø20 série MU				STD	1

Outil	Monokit			
Date	03/07/2023	Version	page n° 6 / 9	
Feuille	B-Plan assemblage			

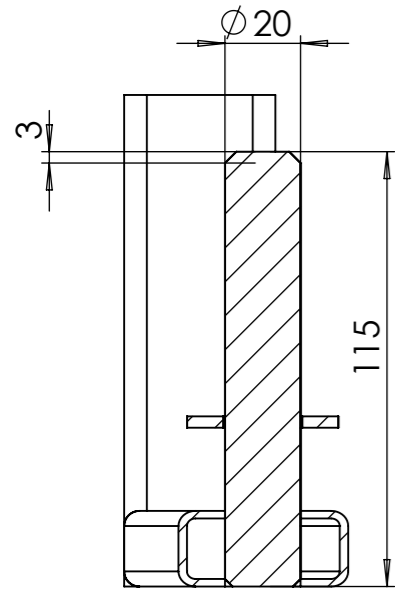

COUPE B-B
ECHELLE 1 : 2

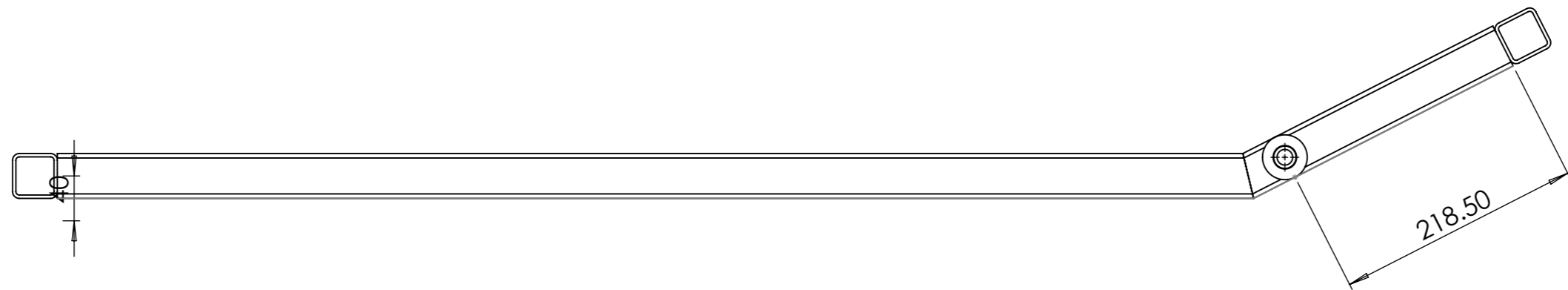
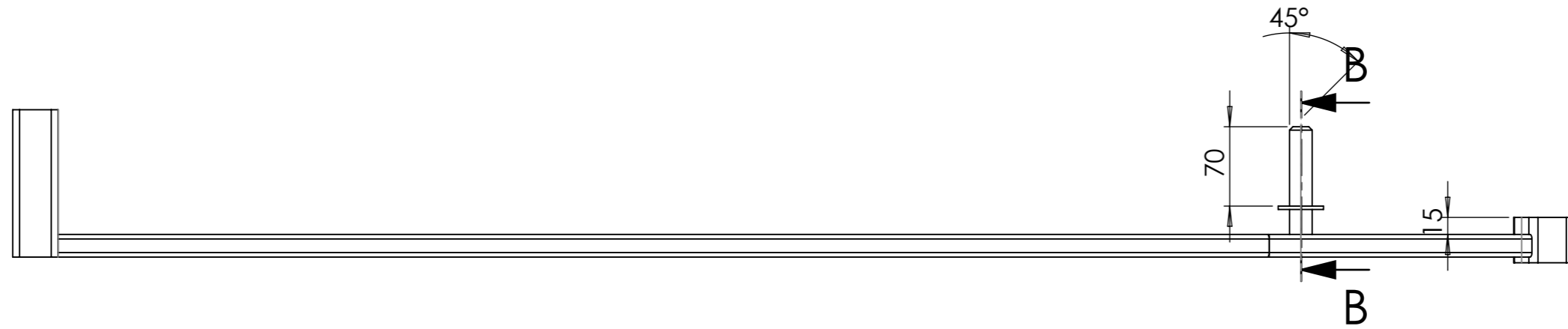

Outil	Monokit			
Date	03/07/2023	Version	page n° 7 / 9	
Feuille	B-detail			

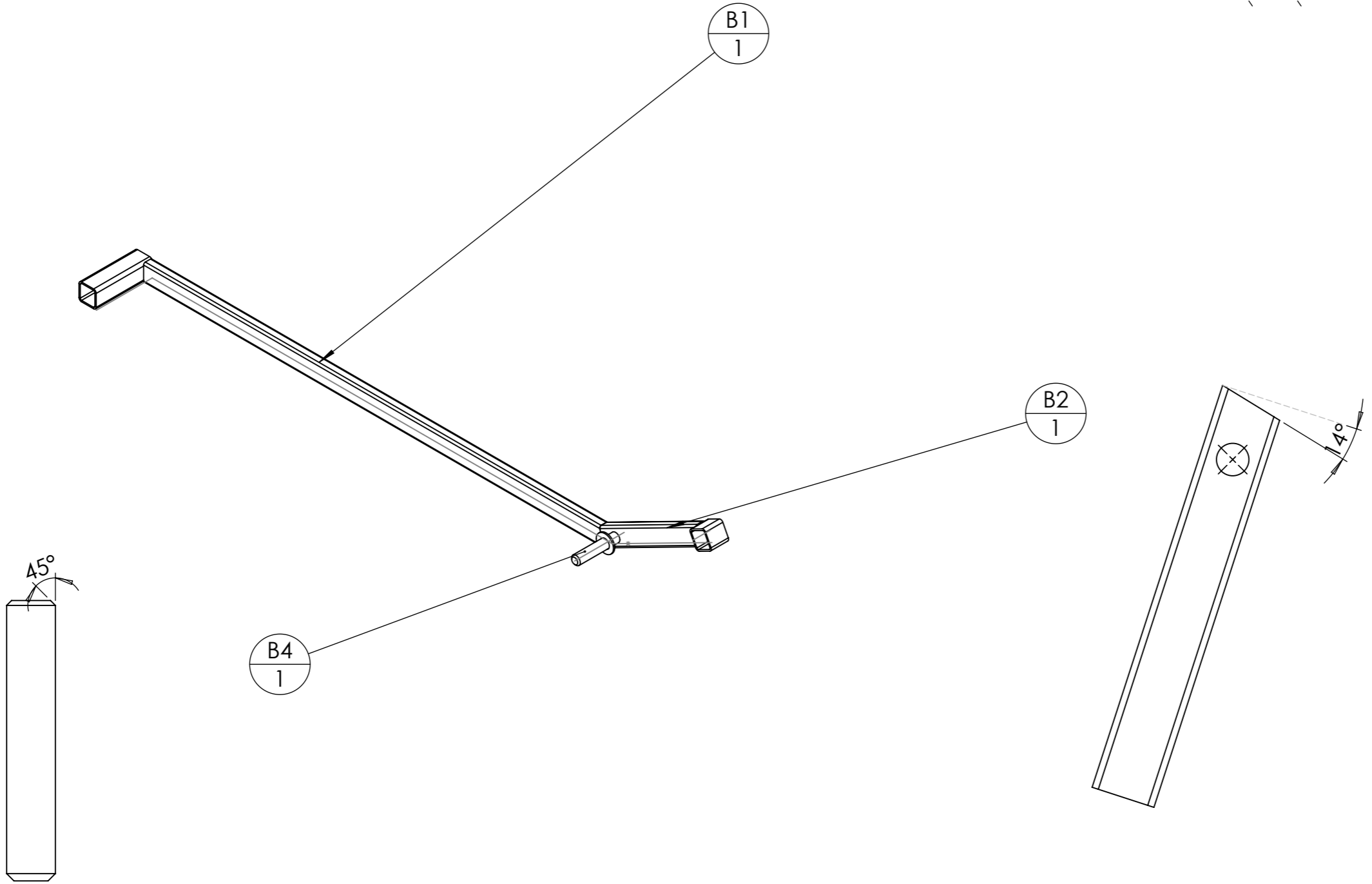
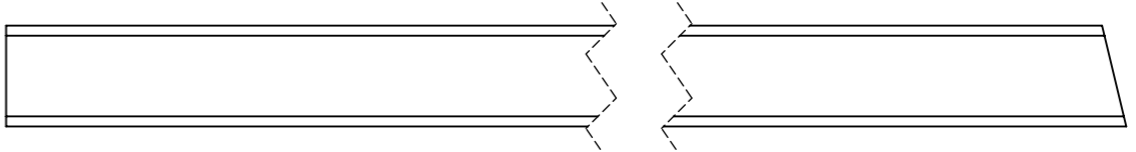

Outil	Monokit			
Date	03/07/2023	Version	page n° 8 / 9	
Feuille	Platine			



Platine pouvant être réalisée à partir d'un fer plat

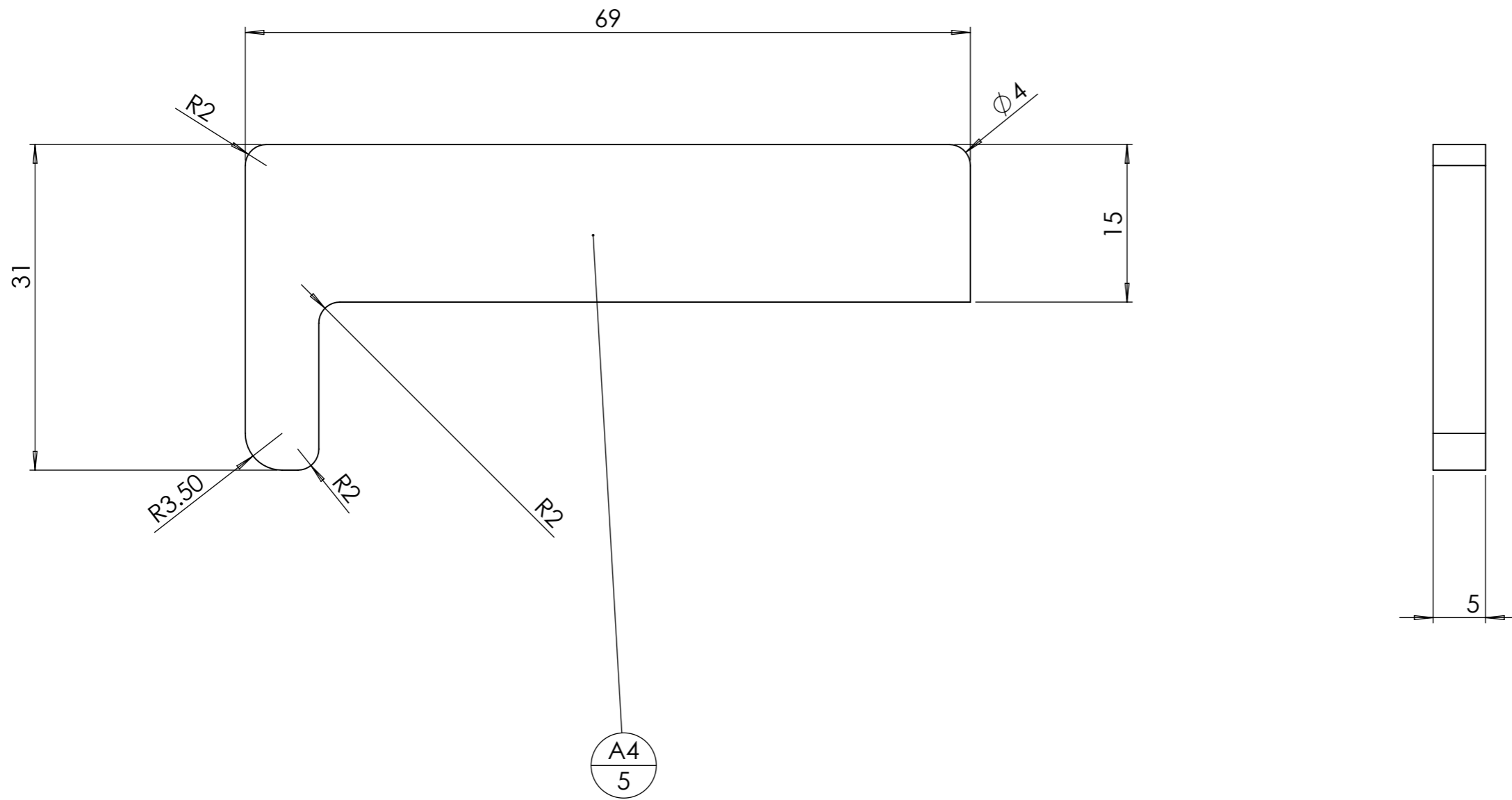

Outil	Monokit			
Date	03/07/2023	Version	page n° 9 / 9	
Feuille	Pièces			

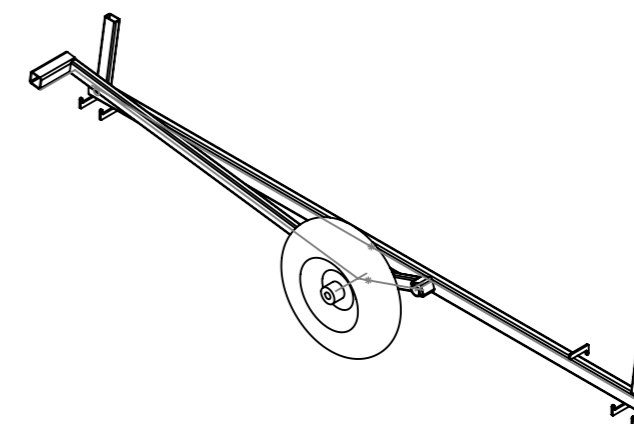

repère	Désignation	ANGLE1	ANGLE2	p	LONGUEUR	Quantité
roue monokit serre	Roue brouette 400x100 axe 20 mm				STD	1
B1	tube rectangulaire 40 x 20 x 2	13.50	0.00		1067.9	1
B2	tube rectangulaire 40 x 20 x 2	0.00	13.50	20	260	1
B3	tube carré 40 x 3	0.00	0.00		130	1
B4	étiré rond Ø20	0.00	0.00		115	1
B5	tube carré 40 x 3	0.00	0.00		40	1
B6	Rondelle Ø20 série MU				STD	1
A1	tube rectangulaire 50 x 25 x 2.5	0°	0°		2090	1
A2	tube rectangulaire 40 x 20 x 2	9°	9°	6 percages d20	205.6607	1
A3	tube rond 33.7 x 2.9	0°	0°		60	1
A4					SPE	5
A	tube rectangulaire 40 x 20 x 2	9°	9°		205.6607	1