

repère	Désignation	Quantité
A	Barre de maintien	1
B	Barre de roue	1
roue mono kit serre	Roue brouette 400x100 axe 20 mm	1

Outil	Monokit		
Date	16/11/2022	Version	page n° 2 / 9
Feuille	Encombrement		

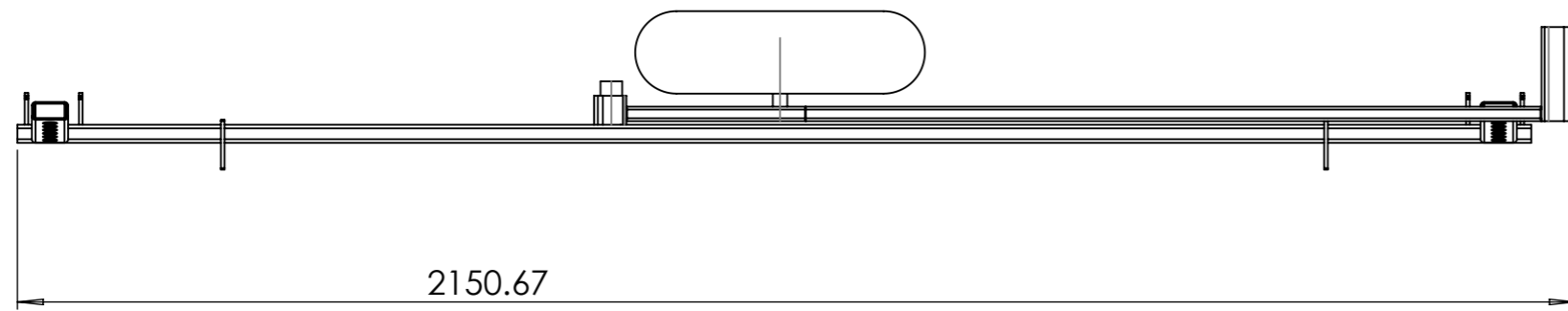

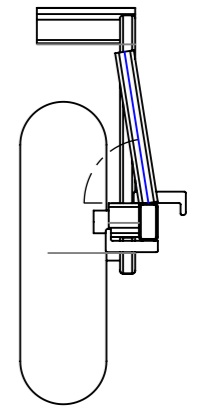

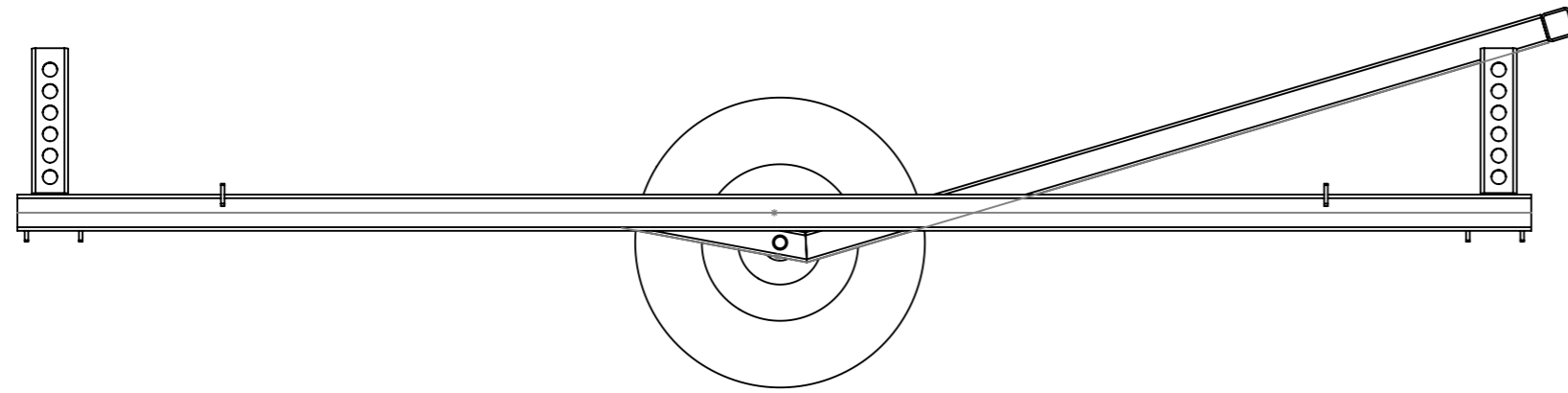
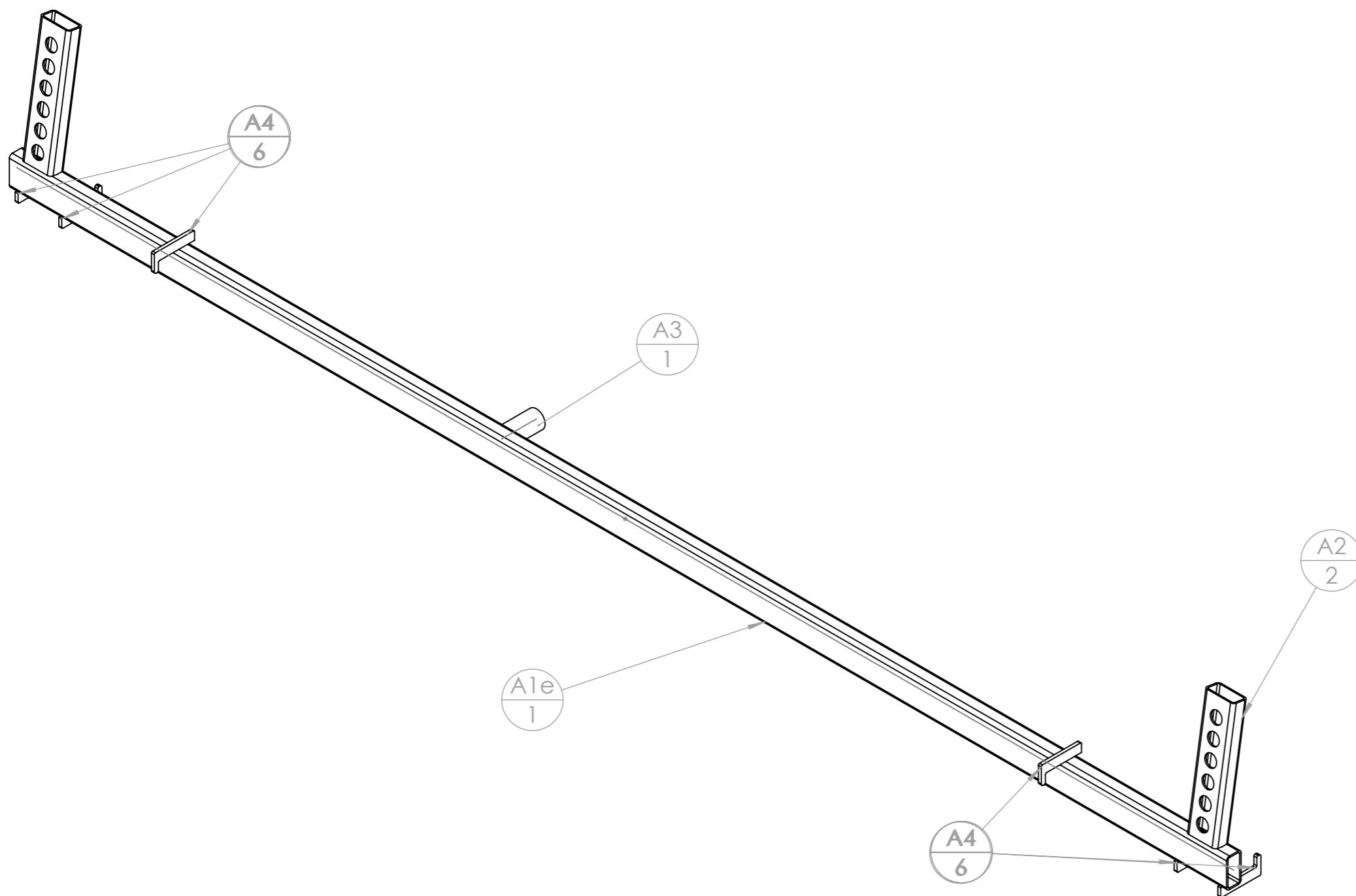

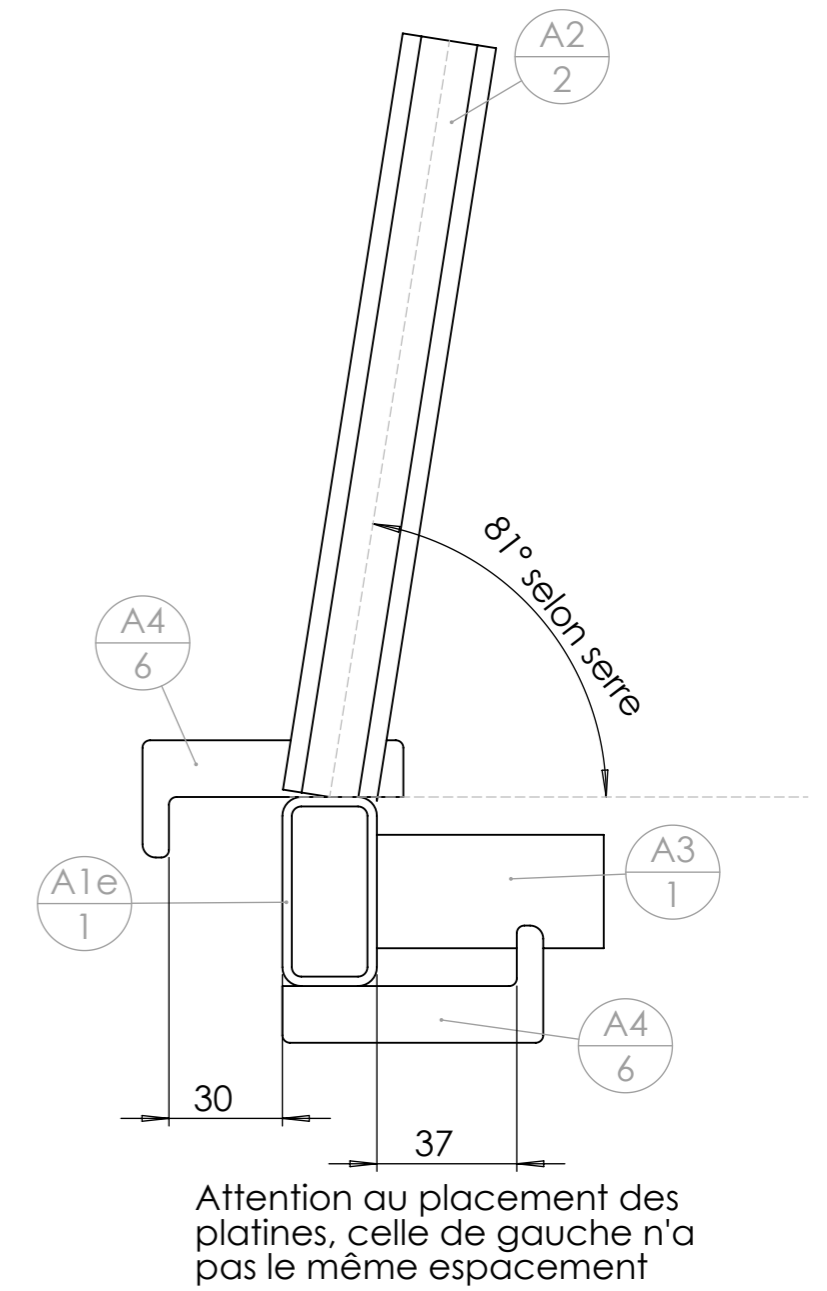
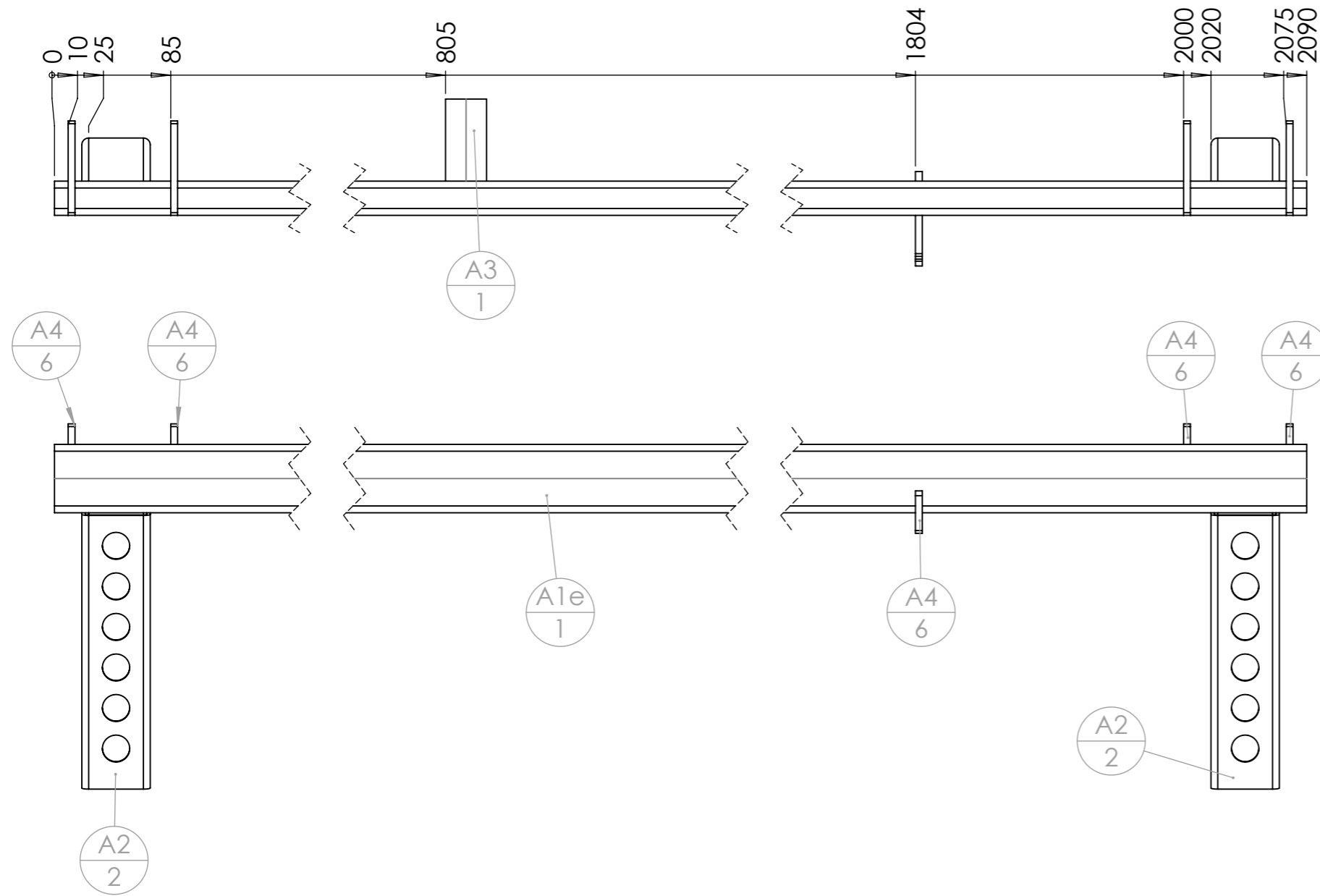
repère	Désignation	ANGLE1	ANGLE2	p	LONGUEUR	Quantité
A1e	tube rectangulaire 50 x 25 x 2.5	0°	0°		2090	1
A3	tube rond 30 x 2	0°	0°		60	1
A4	A4 platine Monokit				SPE	6
A2	tube rectangulaire 50 x 25 x 2.5	0°	-	20	202.493	2



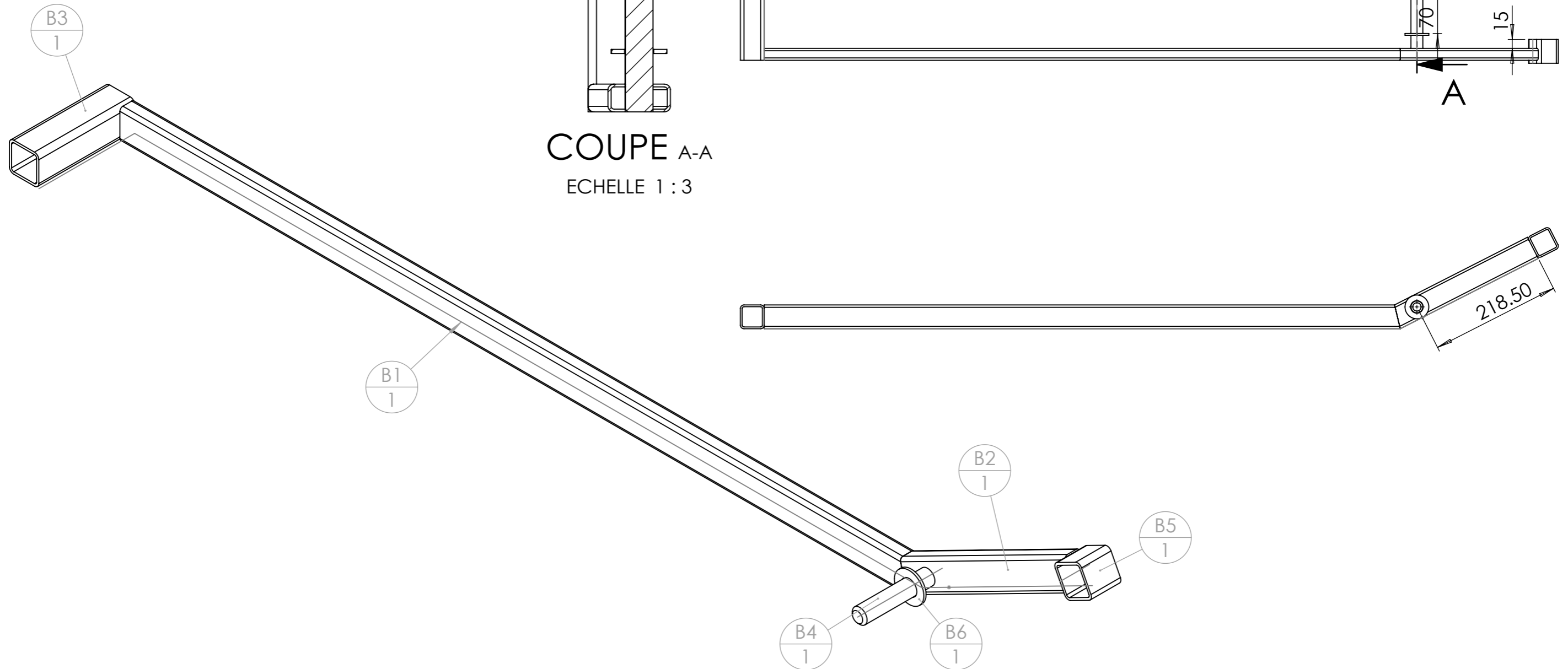

No.ARTICLE	QUANTITÉ	DESCRIPTION	LONGUEUR
1	1	tube rectangulaire 50 x 25 x 2.5	2090
2	2	tube rectangulaire 50 x 25 x 2.5	202.493
3	1	tube rond 30 x 2	60
4	6	A4 platine Monokit	

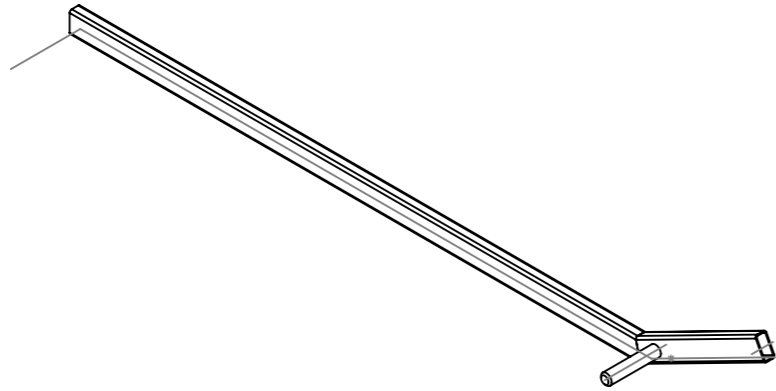

repère	Désignation	ANGLE1	ANGLE2	p	LONGUEUR	Quantité
B					STD	1
B1	tube rectangulaire 40 x 20 x 2	13.50	0.00		1067.9	1
B2	tube rectangulaire 40 x 20 x 2	0.00	13.50	20	260	1
B3	tube carré 40 x 3	0.00	0.00		130	1
B4	étiré rond Ø20	0.00	0.00		115	1
B5	tube carré 40 x 3	0.00	0.00		40	1
B6	Rondelle Ø20 série MU				STD	1

Outil	Monokit			
Date	16/11/2022	Version	page n° 6 / 9	
Feuille	B - Détail			



Outil	Monokit			
Date	16/11/2022	Version	page n° 7 / 9	
Feuille	Platine			

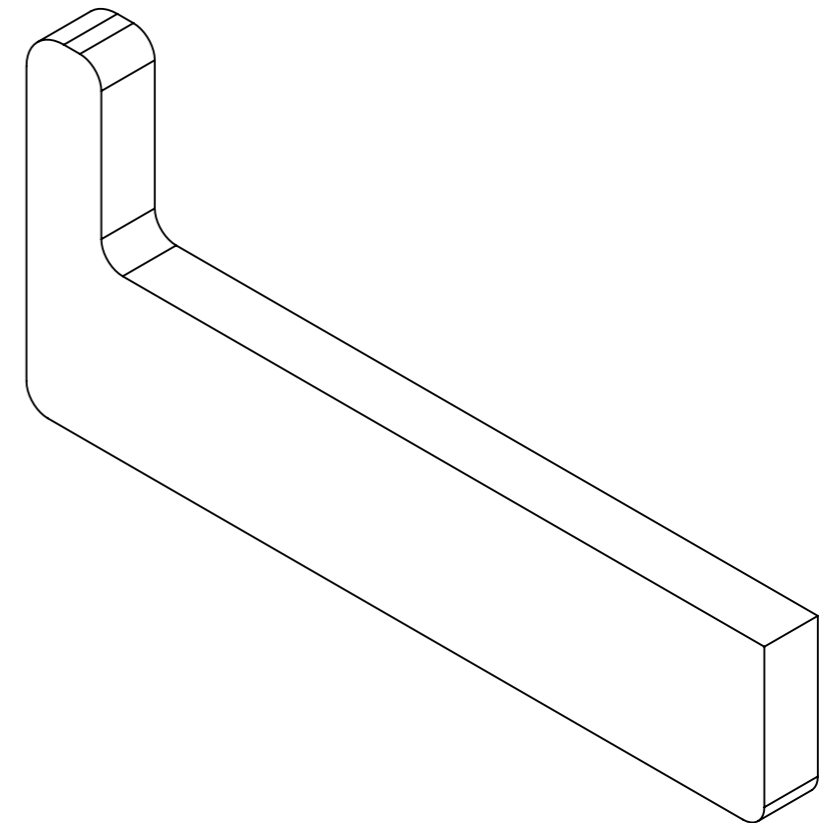
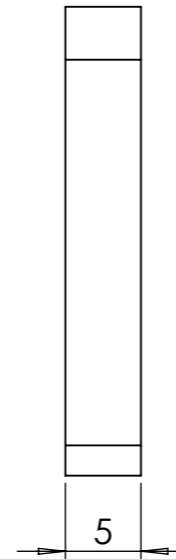
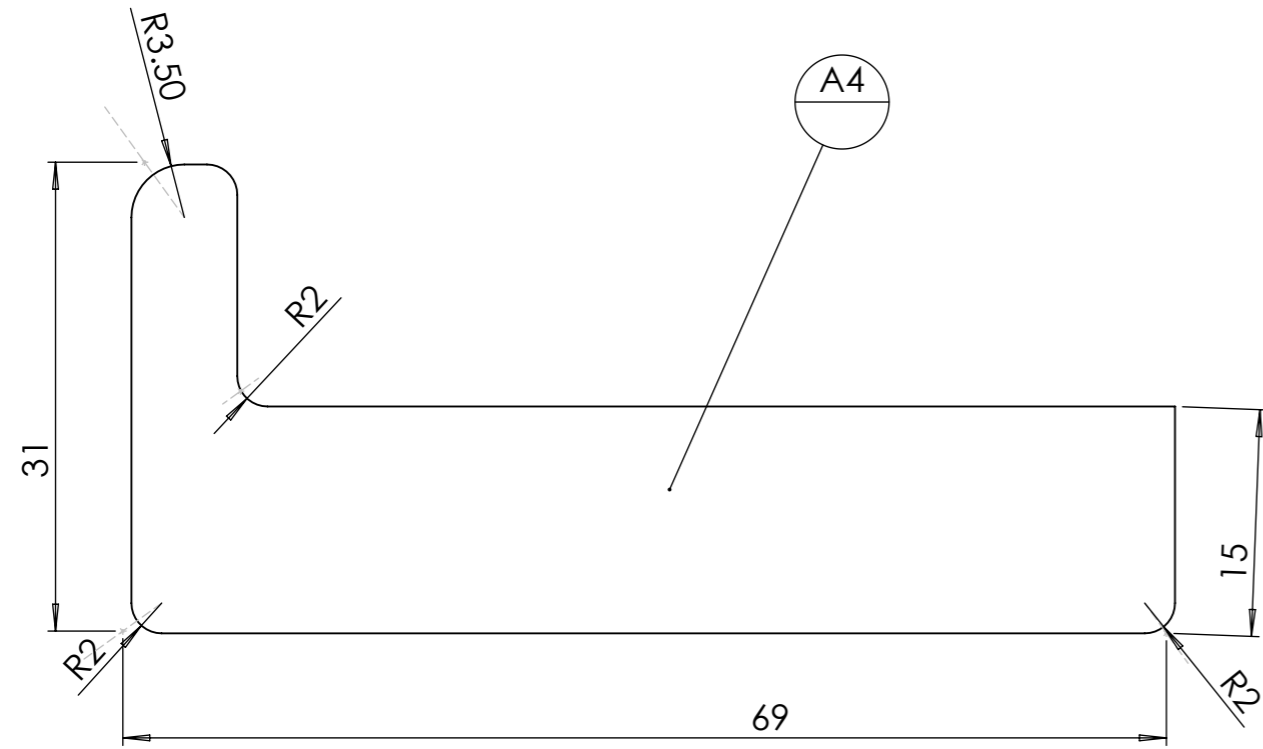

Platine pouvant être réalisé à partir d'un fer plat.

Outil	Monokit			
Date	16/11/2022	Version	page n° 8 / 9	
Feuille	Pièce			

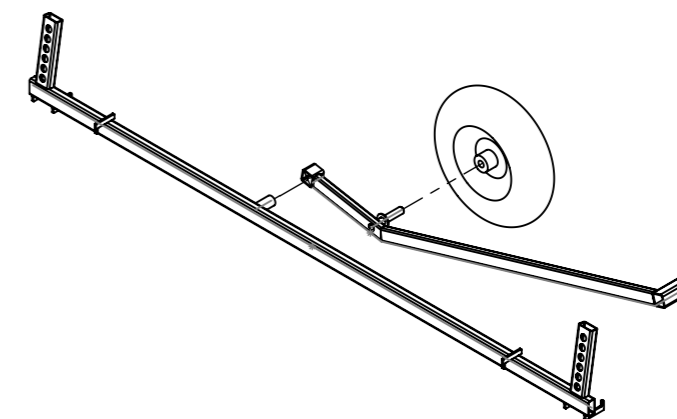



Table de nomenclature (restructuré)

repère	Désignation	ANGLE1	ANGLE2	p	LONGUEUR	Quantité
A1e	tube rectangulaire 50 x 25 x 2.5	0°	0°		2090	1
A2	tube rectangulaire 50 x 25 x 2.5	0°	-	20	202.493	2
A3	tube rond 30 x 2	0°	0°		60	1
A4	A4 platine Monokit				SPE	6
B1	tube rectangulaire 40 x 20 x 2	13.50	0.00		1067.9	1
B2	tube rectangulaire 40 x 20 x 2	0.00	13.50	20	260	1
B3	tube carré 40 x 3	0.00	0.00		130	1
B4	étiré rond Ø20	0.00	0.00		115	1
B5	tube carré 40 x 3	0.00	0.00		40	1
B6	Rondelle Ø20 série MU				STD	1
roue monokit serre	Roue brouette 400x100 axe 20 mm				STD	1

Outil	Monokit			
Date	16/11/2022	Version	page n° 9 / 9	
Feuille	Feuille9			



repère	Désignation	ANGLE1	ANGLE2	p	LONGUEUR	Quantité
A						1
A1e	tube rectangulaire 50 x 25 x 2.5	0°	0°		2090	1
A2	tube rectangulaire 50 x 25 x 2.5	0°	-	20	202.493	2
A3	tube rond 30 x 2	0°	0°		60	1
A4	A4 platine Monokit					6
B						1
B1	tube rectangulaire 40 x 20 x 2	13.50	0.00		1067.9	1
B2	tube rectangulaire 40 x 20 x 2	0.00	13.50	20	260	1
B3	tube carré 40 x 3	0.00	0.00		130	1
B4	étiré rond Ø20	0.00	0.00		115	1
B5	tube carré 40 x 3	0.00	0.00		40	1
B6	Rondelle Ø20 série MU					1
roue monokit serre	Roue brouette 400x100 axe 20 mm					1