

Date	08/10/2014	  			
Version	2.0				
Outil	Tréteaux	Pièce	Vue d'ensemble	Qté	1

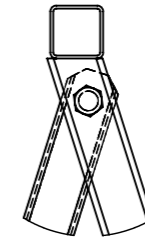

DÉTAIL A
ECHELLE 1 : 5

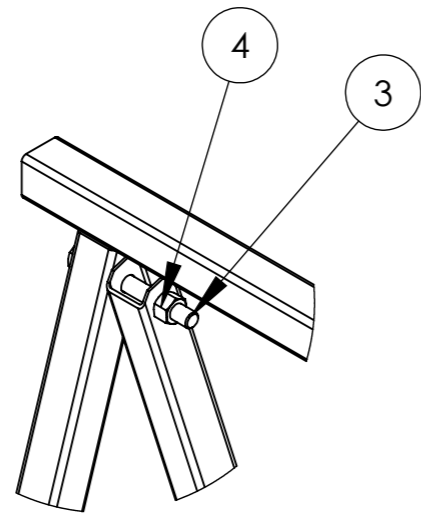
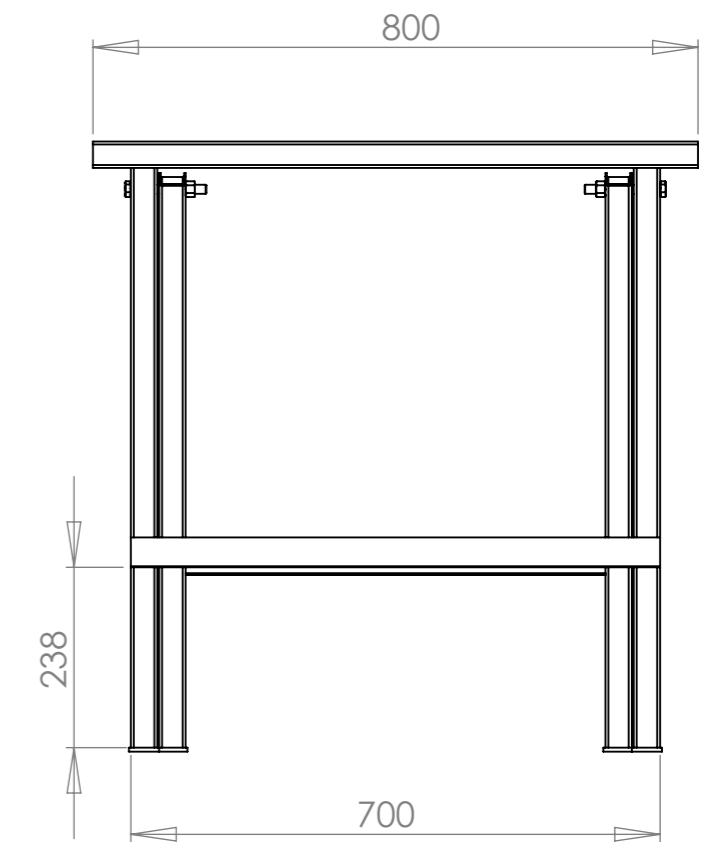
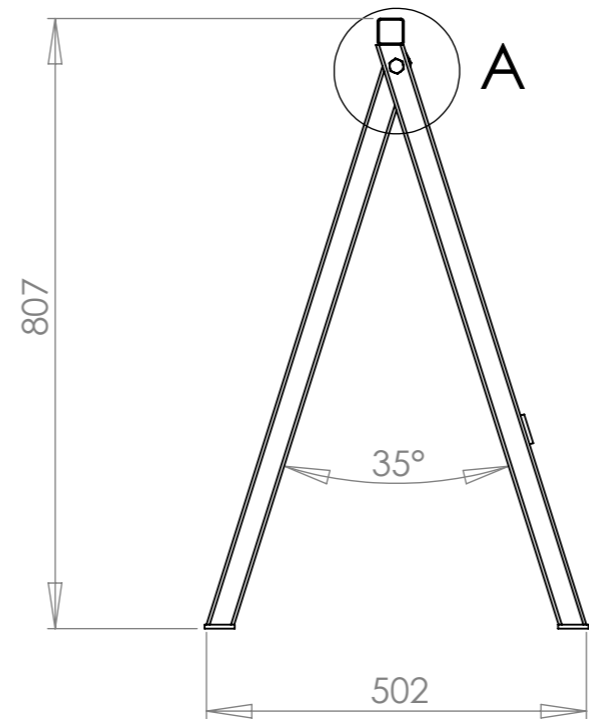
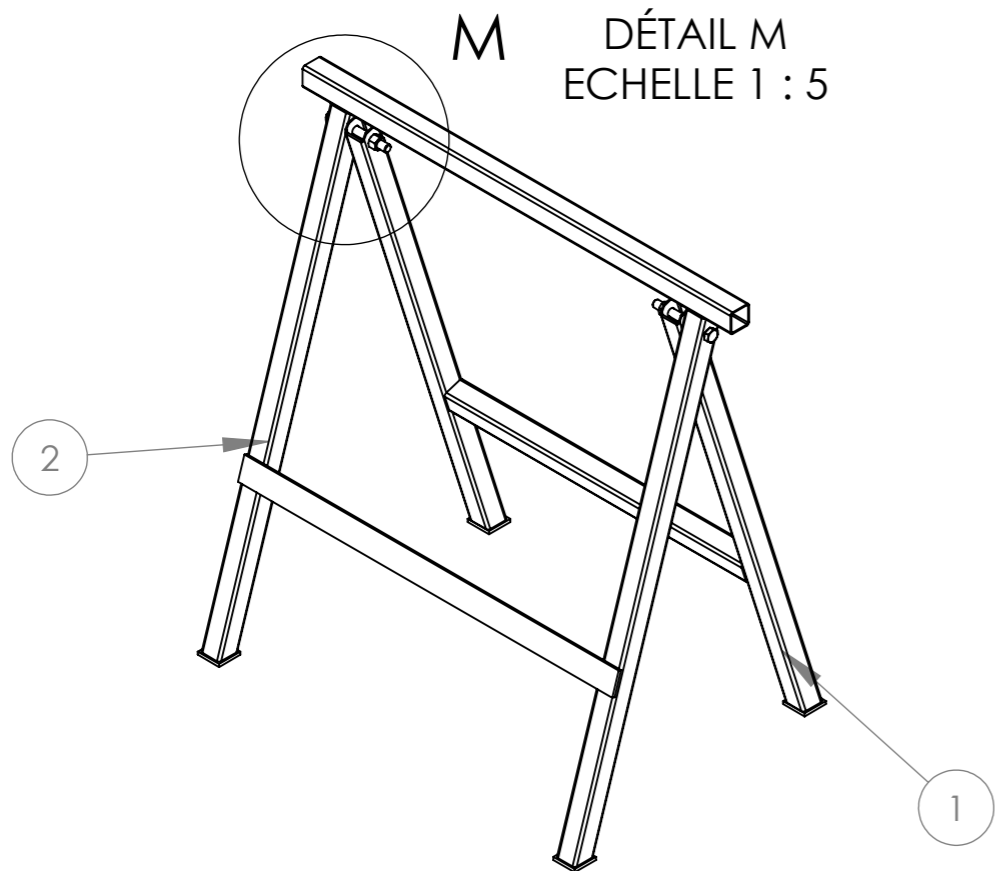

N°	Désignation	Qté
1	A - Pieds extérieurs	1
2	B - Pieds intérieurs	1
3	Vis hexagonale M12 x 100	2
4	Ecrou M12	2

N°	Désignation	Longueur	Qté
A1	tube carré 35 x 2	800	1
A2	tube carré 35 x 2	815	2
A3	Fer plat 40 x 5	700	1
A4	Fer plat 40 x 5	40	4
B1	tube carré 35 x 2	555	1
B2	tube carré 35 x 2	800	2
Vis Hexagonale	Vis hexagonale M12 x 100		2
Ecrou	Ecrou M12		2

Date	08/10/2014				
Version	2.0				
Outil	Tréteaux	Pièce	A et B	Qté	1

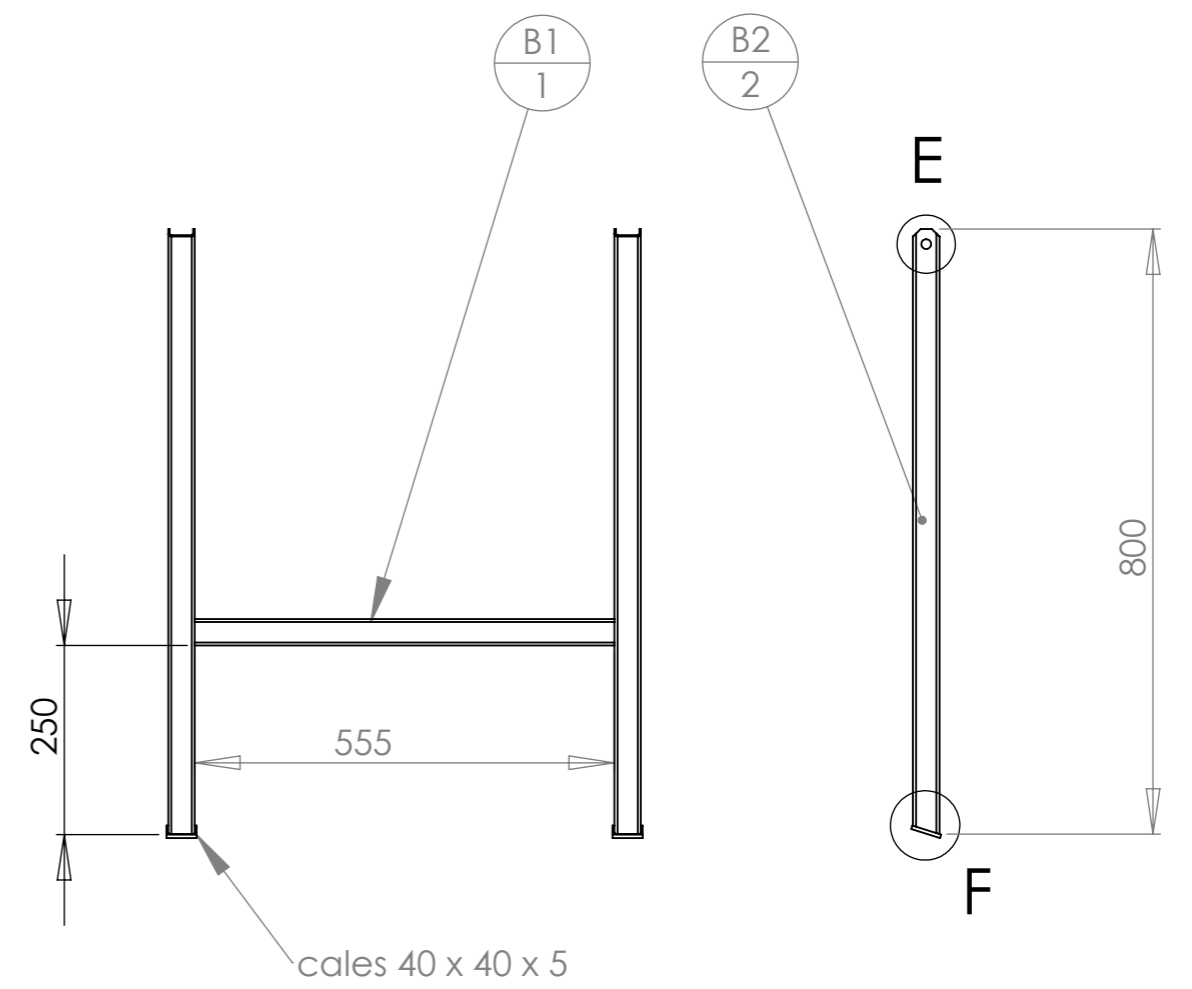
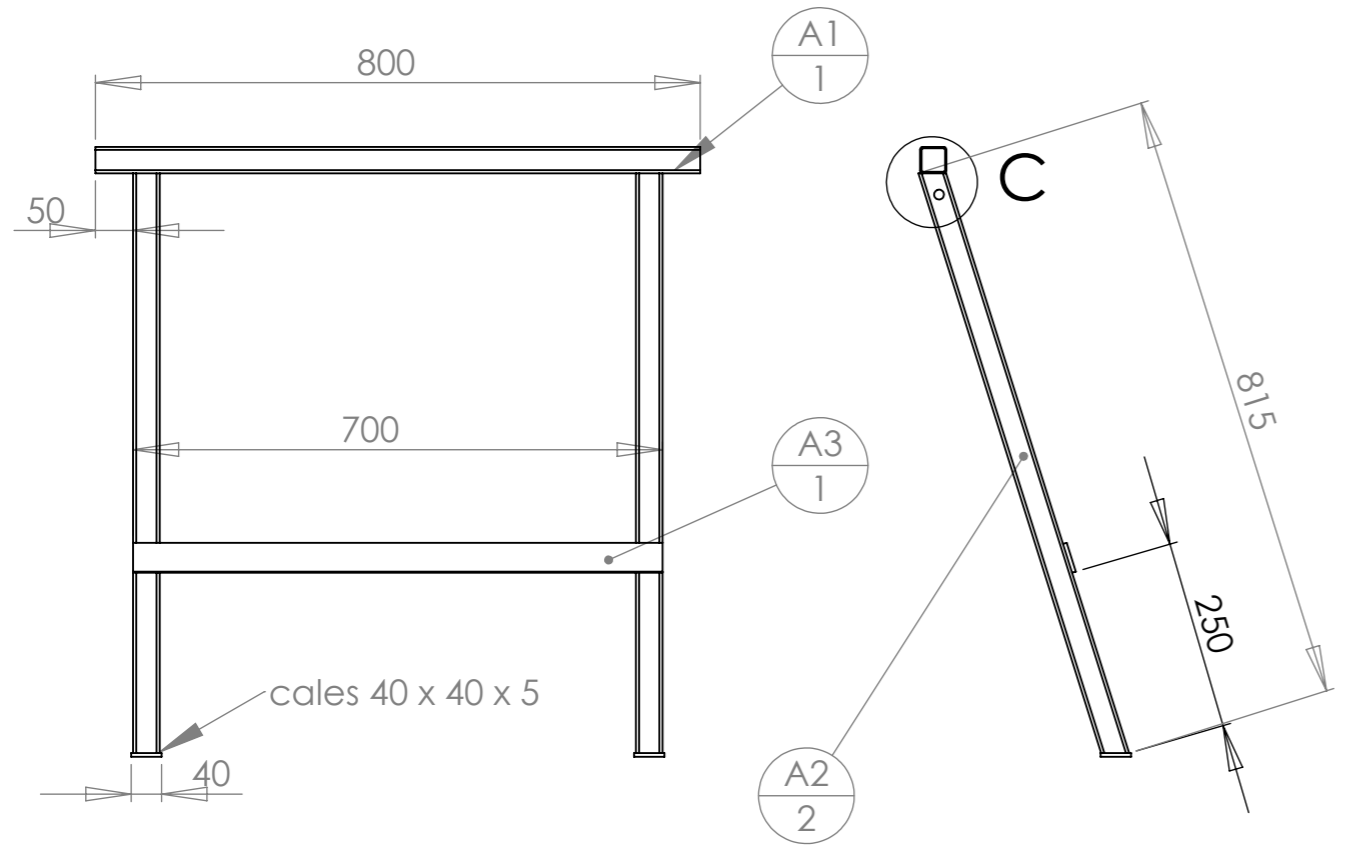
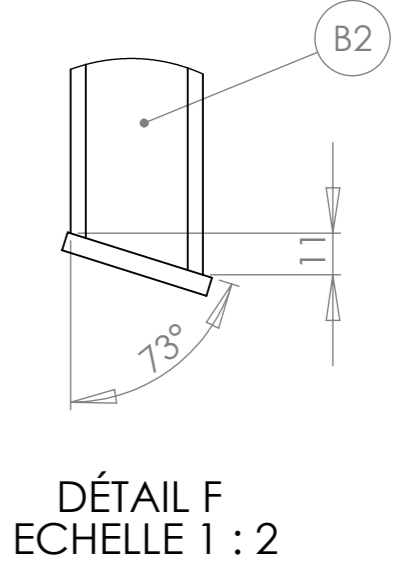
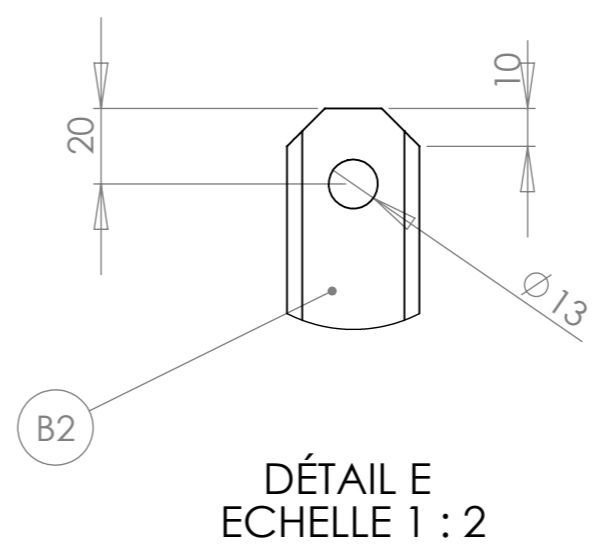
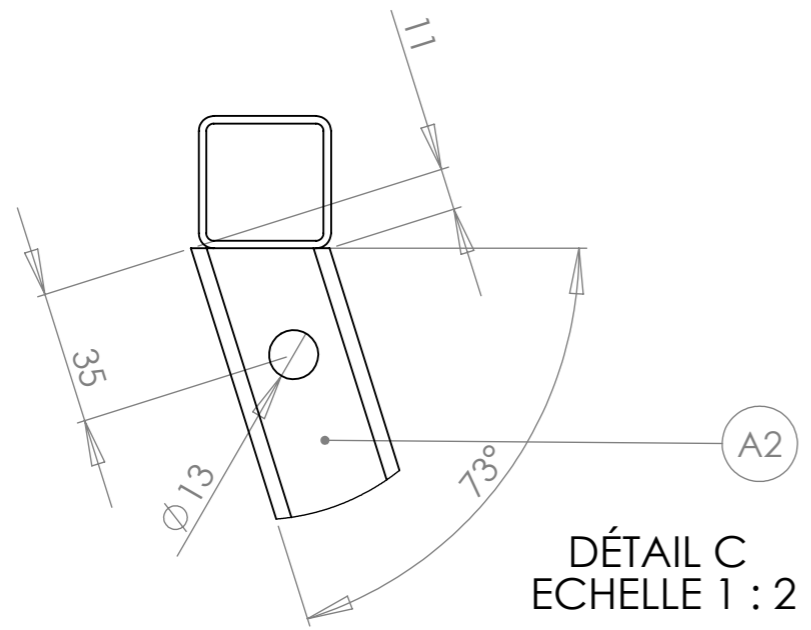

N°	Désignation	Longueur	Qté
A1	tube carré 35 x 2	800	1
A2	tube carré 35 x 2	815	2
A3	Fer plat 40 x 5	700	1
A4	Fer plat 40 x 5	40	2

N°	Désignation	Longueur	Qté
B1	tube carré 35 x 2	555	1
B2	tube carré 35 x 2	800	2
A4	Fer plat 40 x 5	40	2