

Outil	dérouleuse enrouleuse textile				
Date	05/10/2020	Version	0.5	page n° 1 / 11	
Pièce	Préambule		Qté	1	

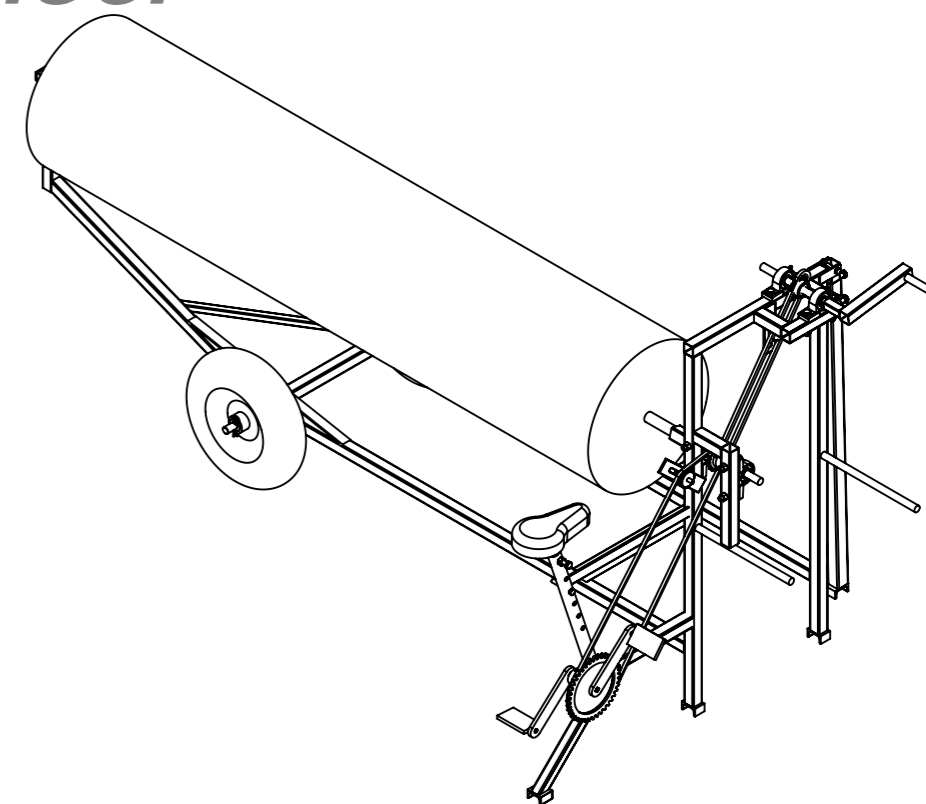

# Avant de commencer



La présente version est le résultat des évolutions par l'usage, d'expérimentations paysannes quotidiennes, des ajustements pratiques issus des retours des participants aux nombreuses formations et journées de terrain collectives.

L'autoconstruction de votre outil à l'aide de ce tutoriel n'est que le début de votre aventure. Si cette machine est pertinente en l'état pour de nombreux contextes, vous allez devoir l'adapter, la régler, la modifier pour l'ajuster à votre projet agronomique, vos itinéraires techniques, vos conditions pédo-climatiques. Vous allez donc faire vivre cette machine.

Merci de nous faire parvenir vos retours, vos découvertes, vos réussites. Vos expériences individuelles, vos tâtonnements de terrain viendront enrichir le pot commun paysan, sous même licence libre que les présents plans.

<http://www.latelierpaysan.org/>



<http://forum.latelierpaysan.org>

Outil	<b>dérouleuse enrouleuse textile</b>				
Date	05/10/2020	Version	0.5		page n° 2 / 11
Feuille	<b>mise au point</b>				



Outil sans option

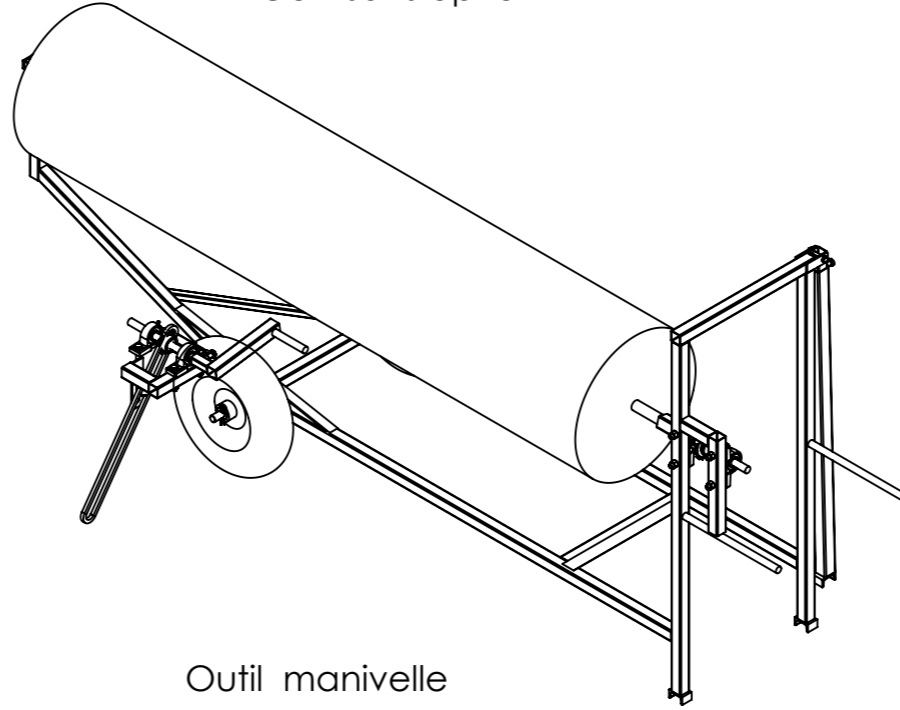

Outil manivelle

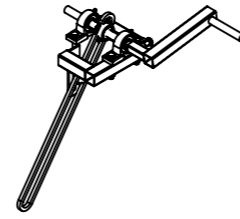



Option Balaie

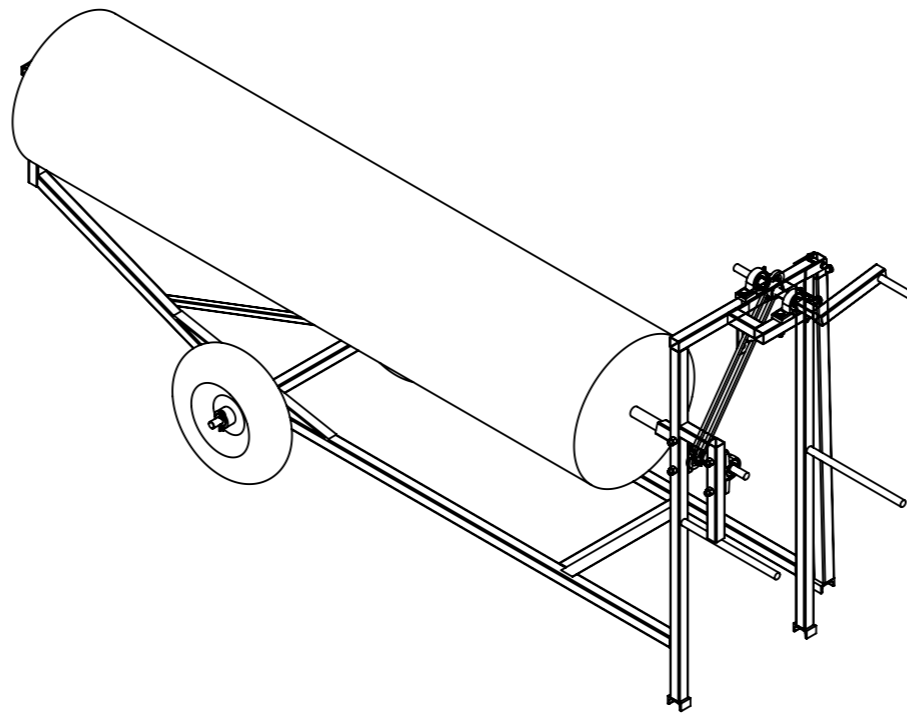
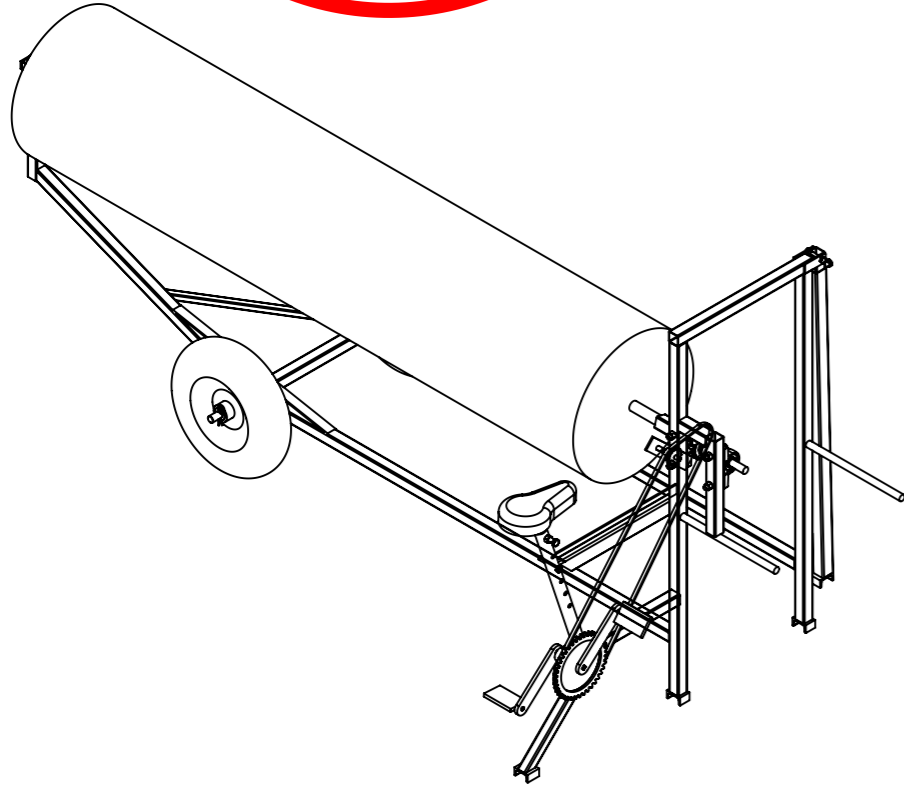
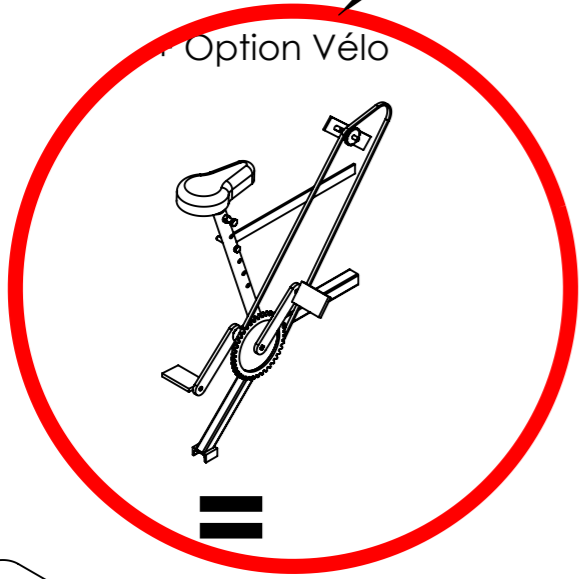

Plan de cet élément

Option Vélo



Outil	<b>dérouleuse enrouleuse textile</b>				
Date	05/10/2020	Version	0.5	page n° 3 / 11	
Pièce	<b>présentation</b>			Qté	

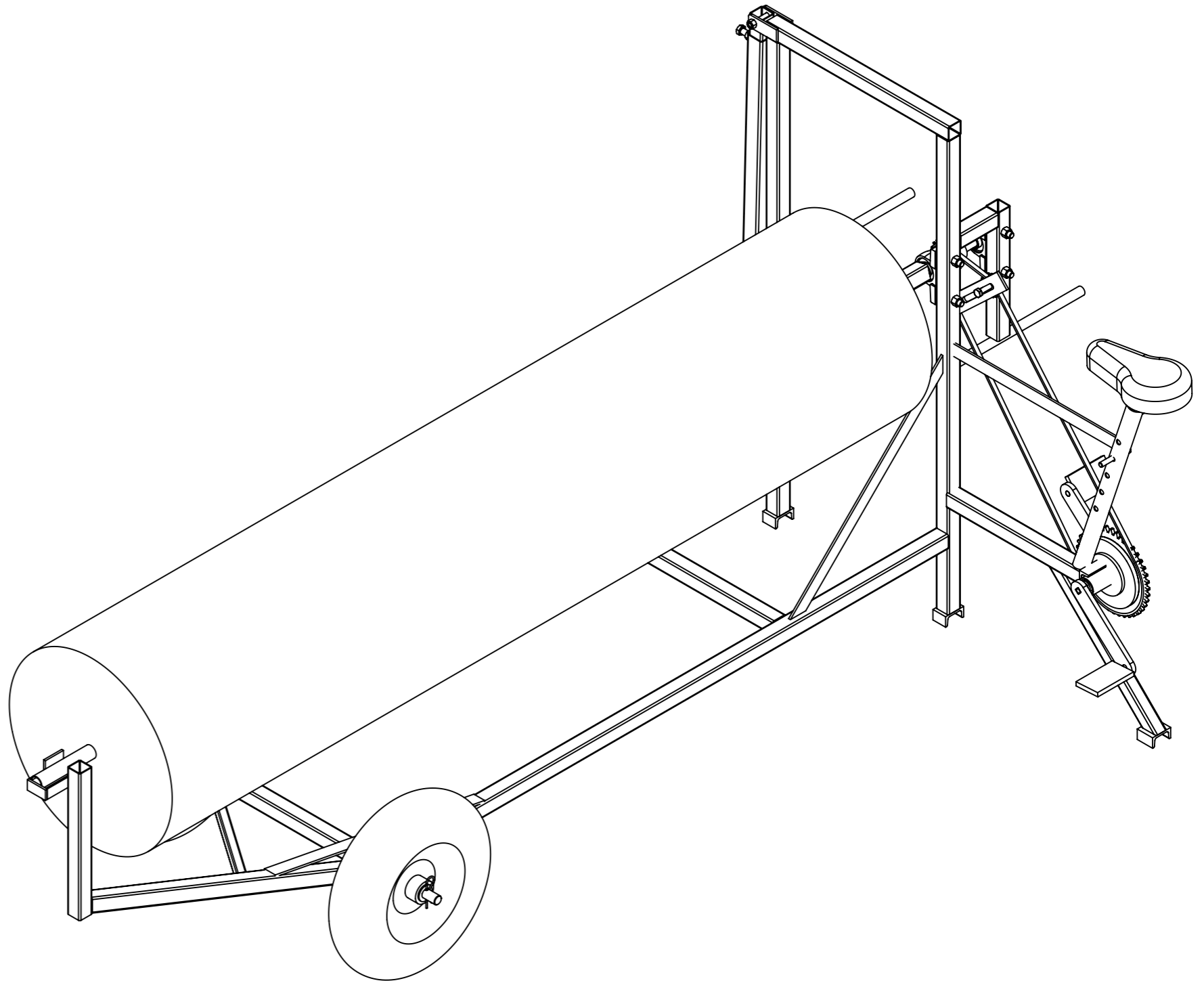
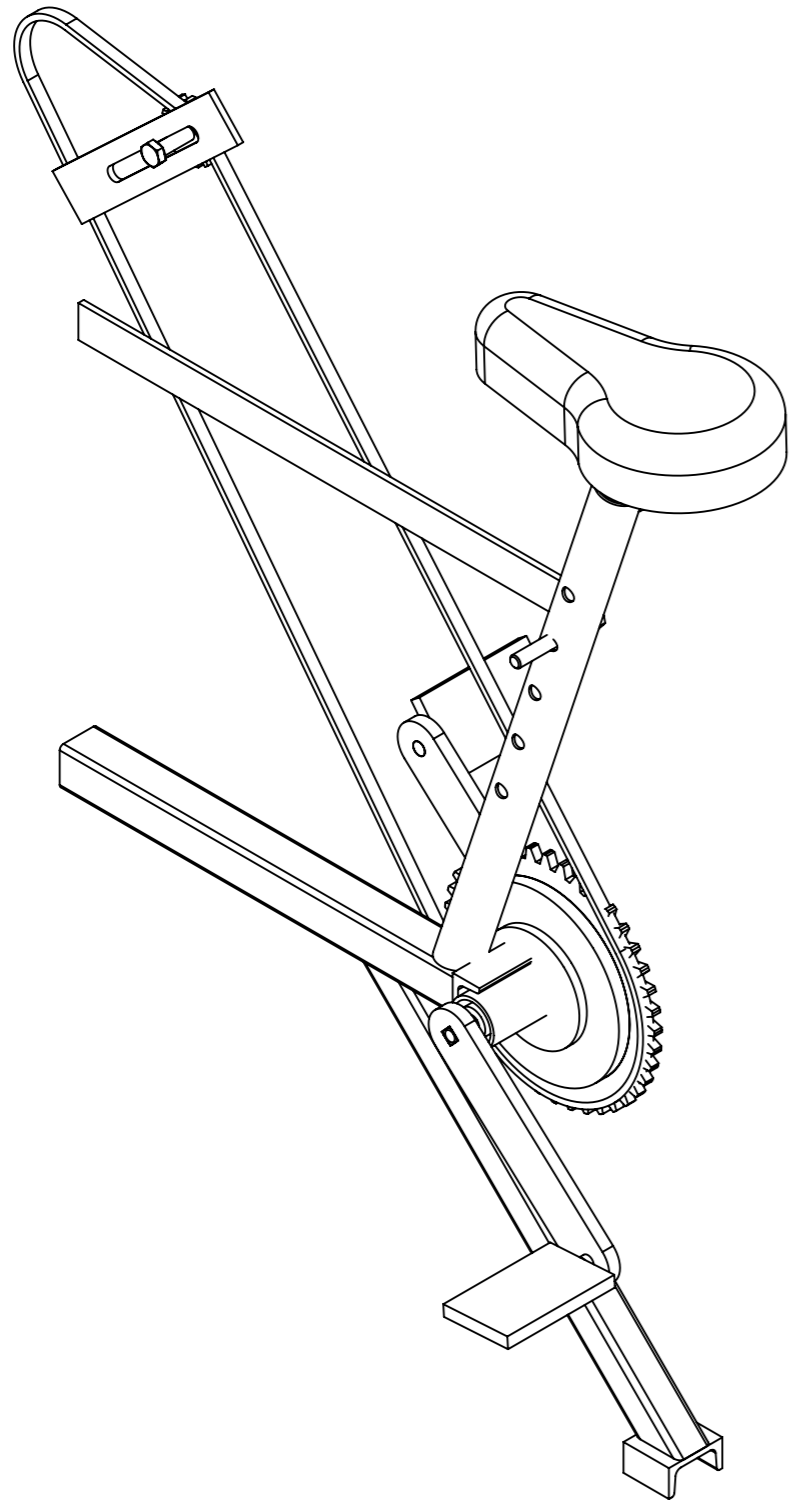

Outil	<b>dérouleuse enrouleuse textile</b>		
Date	05/10/2020	Version	0.5
page n°	4	/ 11	
Feuille	<b>Eclaté général</b>		

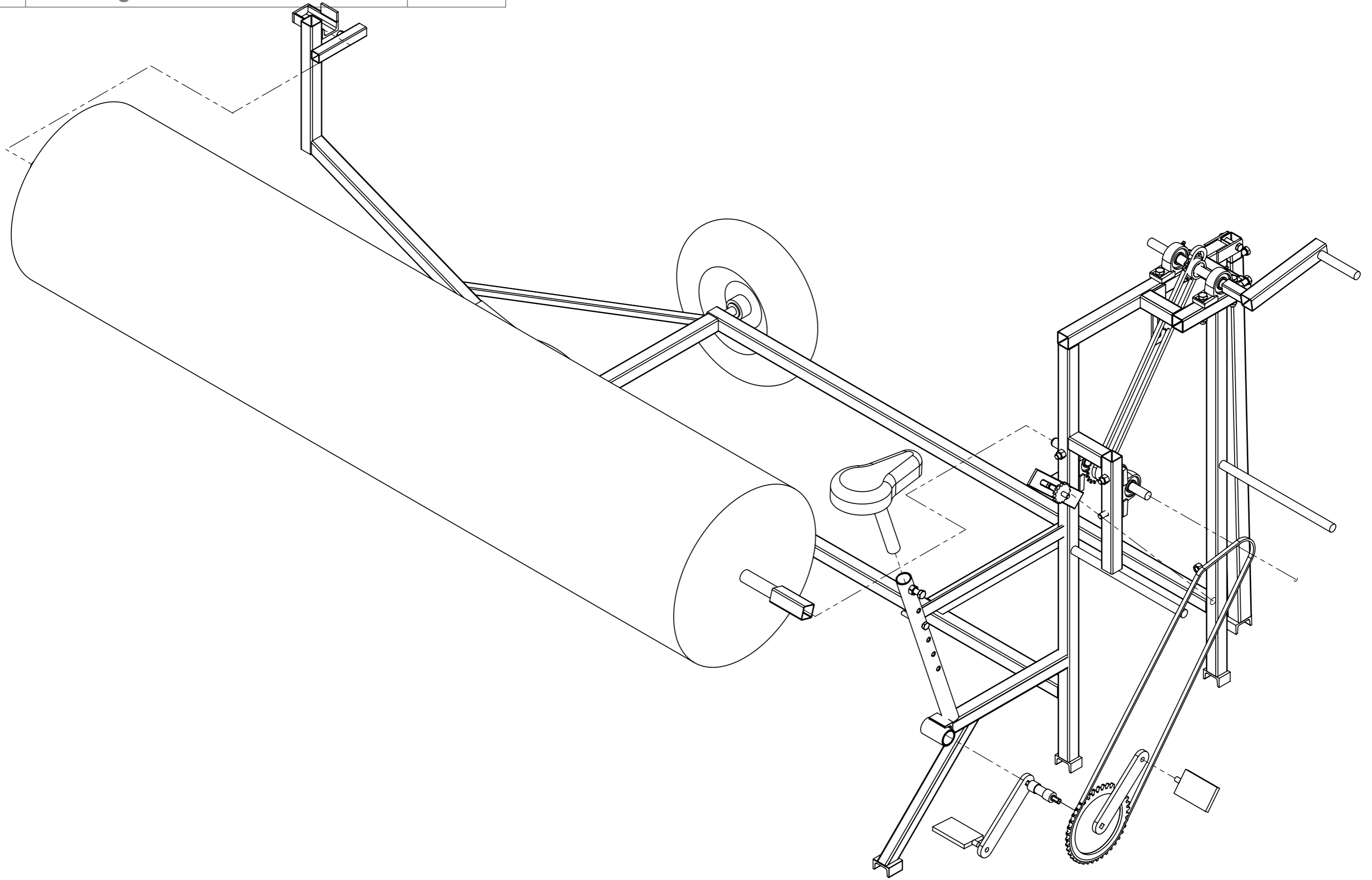

Outil	<b>dérouleuse enrouleuse textile</b>				
Date	05/10/2020	Version	0.5		page n° 5 / 11
Feuille	<b>Encombrement</b>				

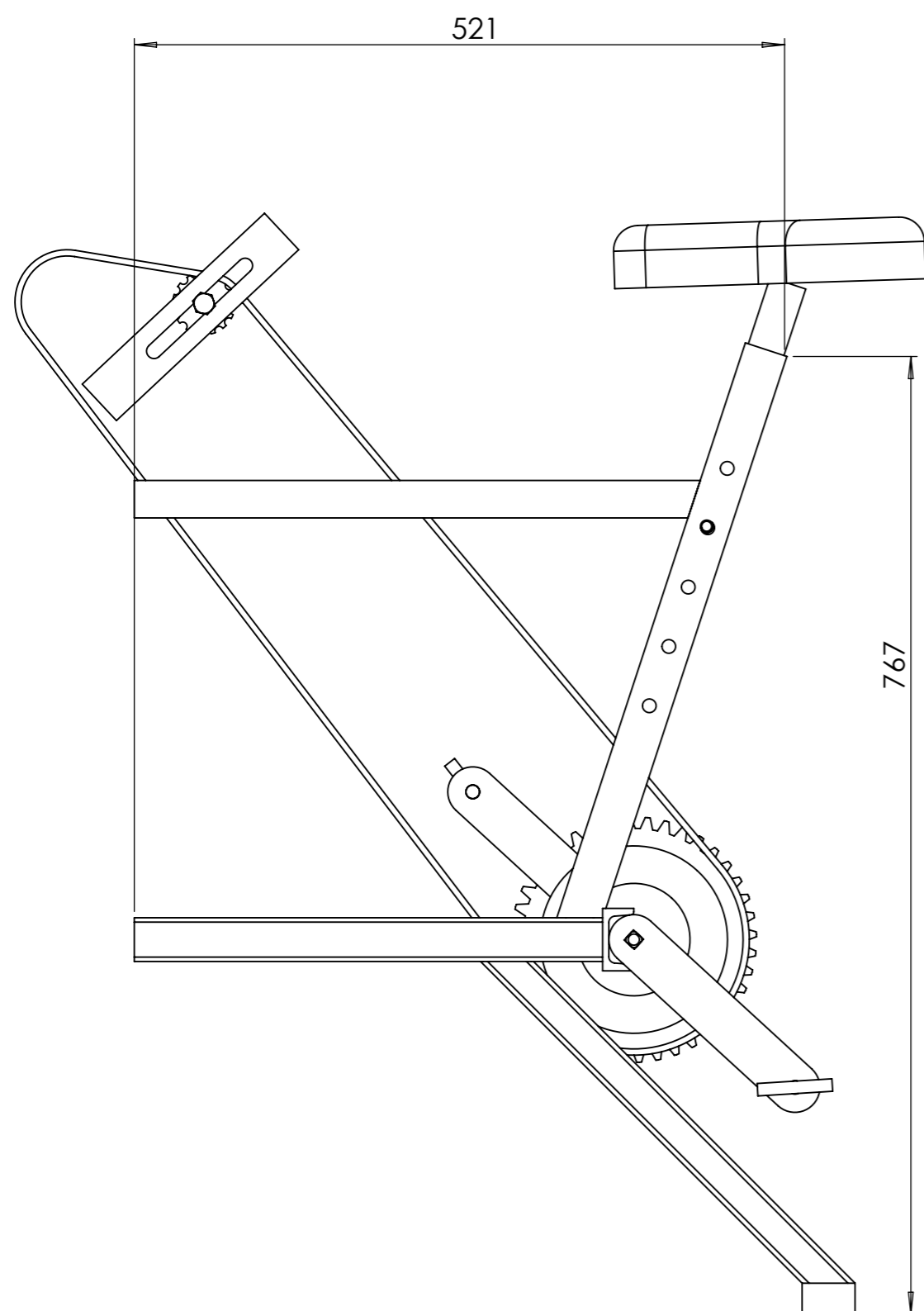

repère	Désignation	Quantité
Vis Hexagonale	Vis hexagonale M12 x 30	1
tendeur simple 15 dents	tendeur simple 08B1	1
selle	selle + tige velo 26mm	1
boitier de pedalier bsa 110-68-un26	Boitier de pédalier	1
pédalier droit	Pédalier	1
pédale	Pédales BMX	2
chaîne	Chaîne à rouleau, 08B1, 1,4m	1
Vis Hexagonale	vis hexagonale M10 x 70	1
A17	tube carré 35 x 2	1
A18	Fer U 50 x 25 x 5	1
A19	tube rond 35 x 2	1
A20	Tube carré 30 x 2	1
A21	fer plat 40 x 5	1
A24	Fer plat 30 x 5	1
A28	Moyeu pédalier	1
A29	Ecrou M12 brut	1
A30	Fer U 50 x 25 x 5	1

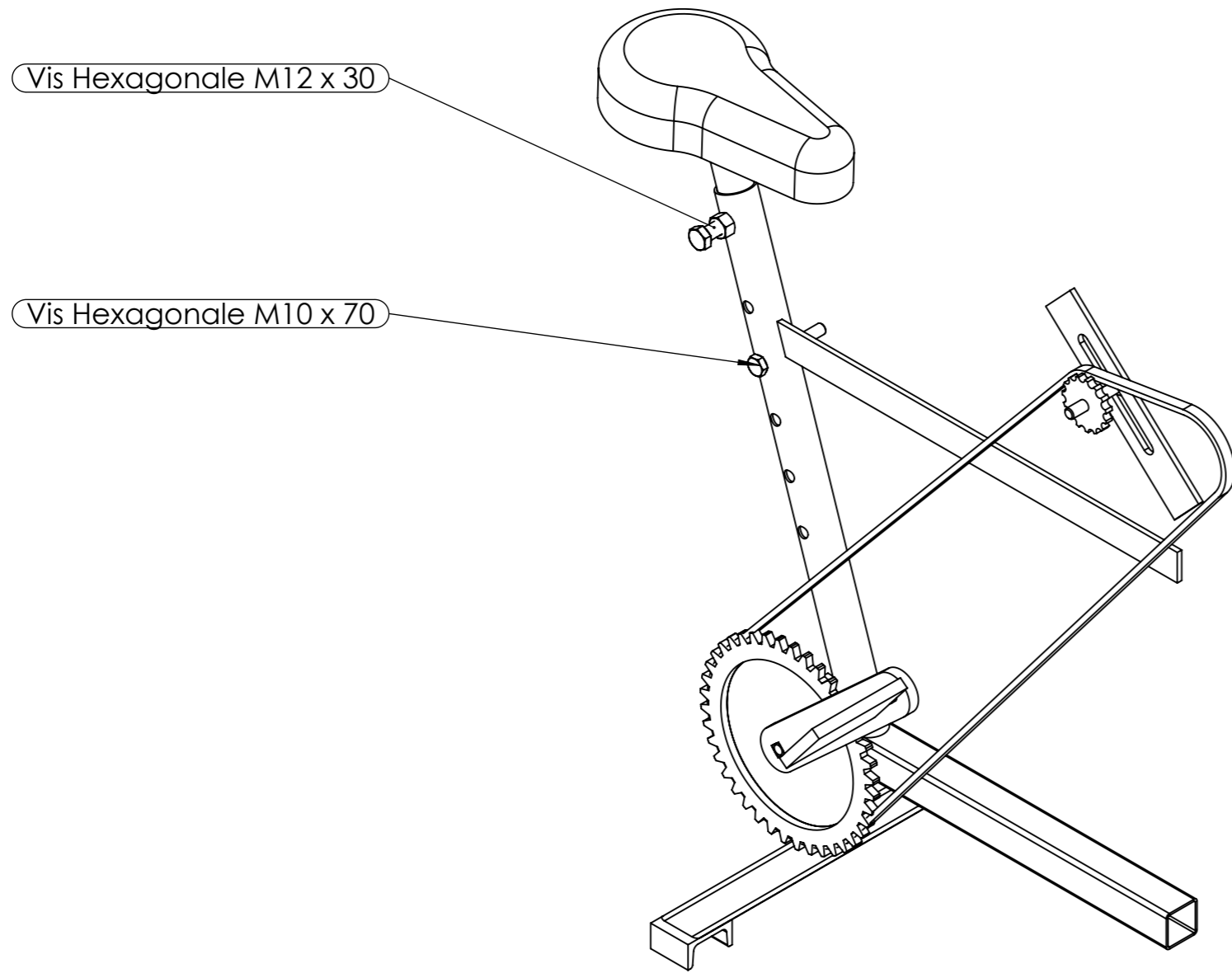

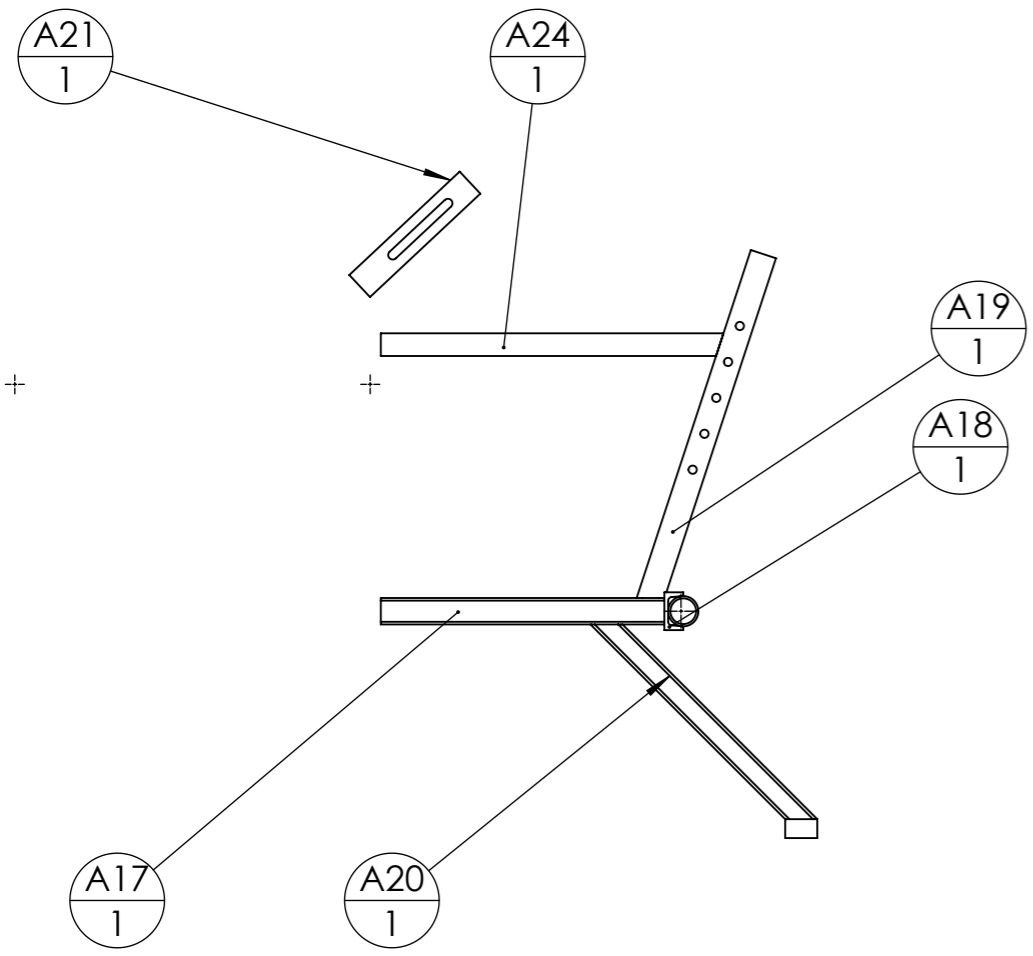

repère	Désignation	Quantité
Vis Hexagonale	Vis hexagonale M12 x 30	1
Vis Hexagonale	vis hexagonale M10 x 70	1

Outil	dérouleuse enrouleuse textile				
Date	05/10/2020	Version	0.5		page n° 7 / 11
Pièce	chassis A		Qté		1

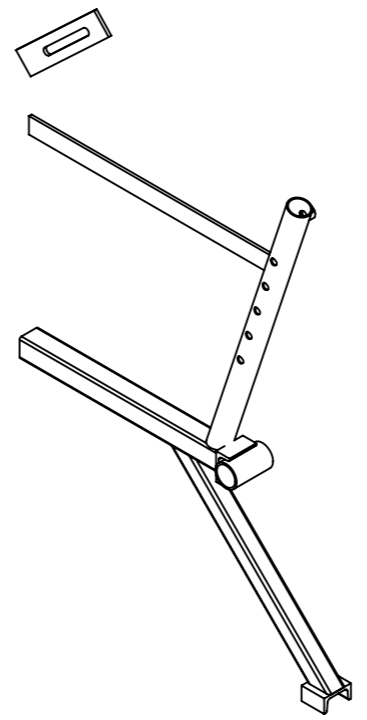

repère	Désignation	ANGLE1	ANGLE2	p	LONGUEUR	Quantité
A17	tube carré 35 x 2	0.00	0.00		375	1
A18	Fer U 50 x 25 x 5	0.00	0.00		50	1
A19	tube rond 35 x 2	18.17	0.00	1x Ø31 ; 1x Ø13 ; 10x Ø11 ;	484	1
A20	Tube carré 30 x 2	45.00	45.00		394	1
A21	fer plat 40 x 5	0.00	0.00		200	1
A24	Fer plat 30 x 5	0.00	-		454	1
A28	Moyeu pédalier					1
A29	Ecrou M12 brut					1
A30	Fer U 50 x 25 x 5	0.00	0.00		42	1



Outil	dérouleuse enrouleuse textile				
Date	05/10/2020	Version	0.5	page n° 8 / 11	
Pièce	Pièce du A		Qté	1	

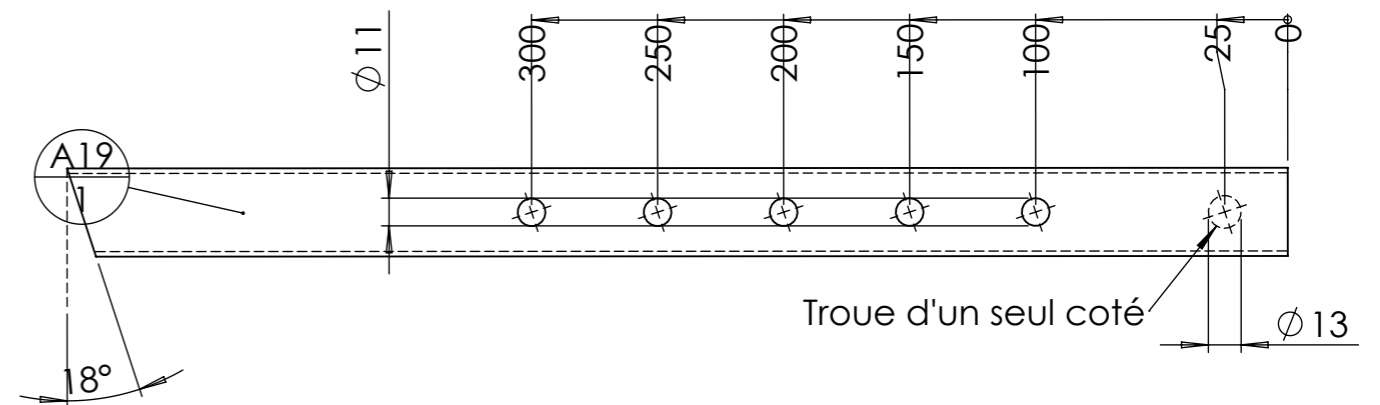
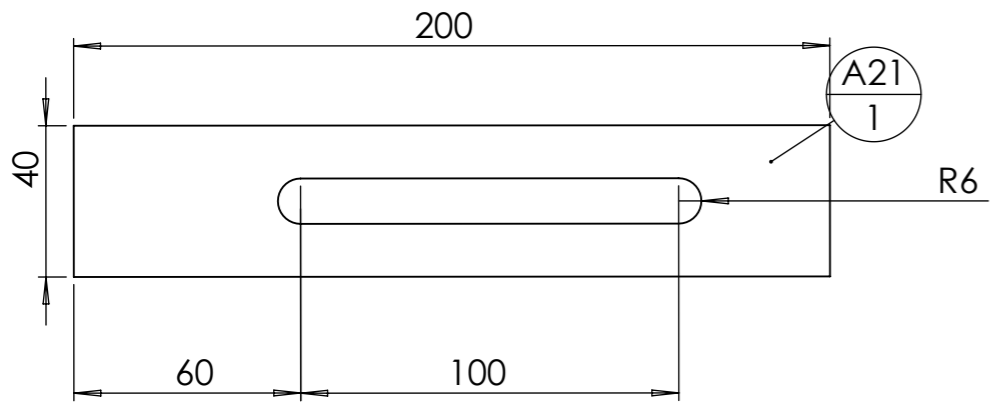
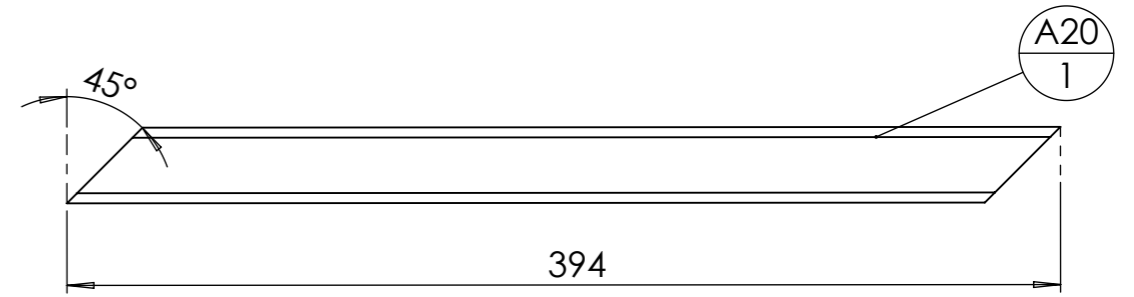
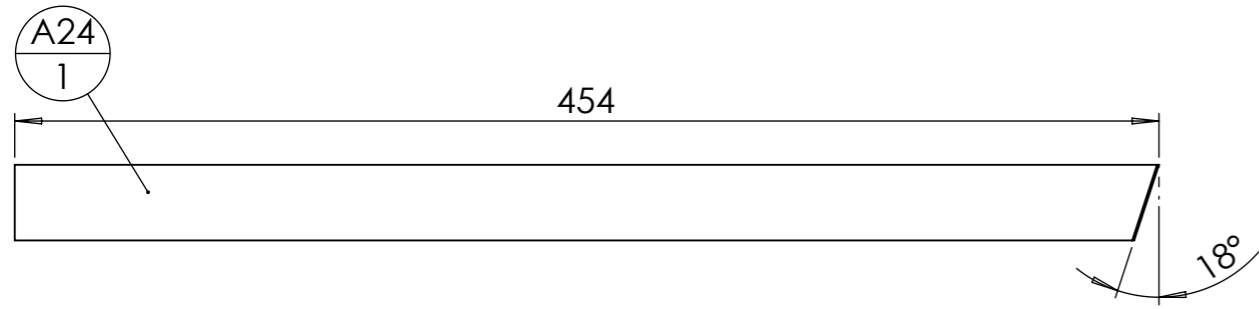
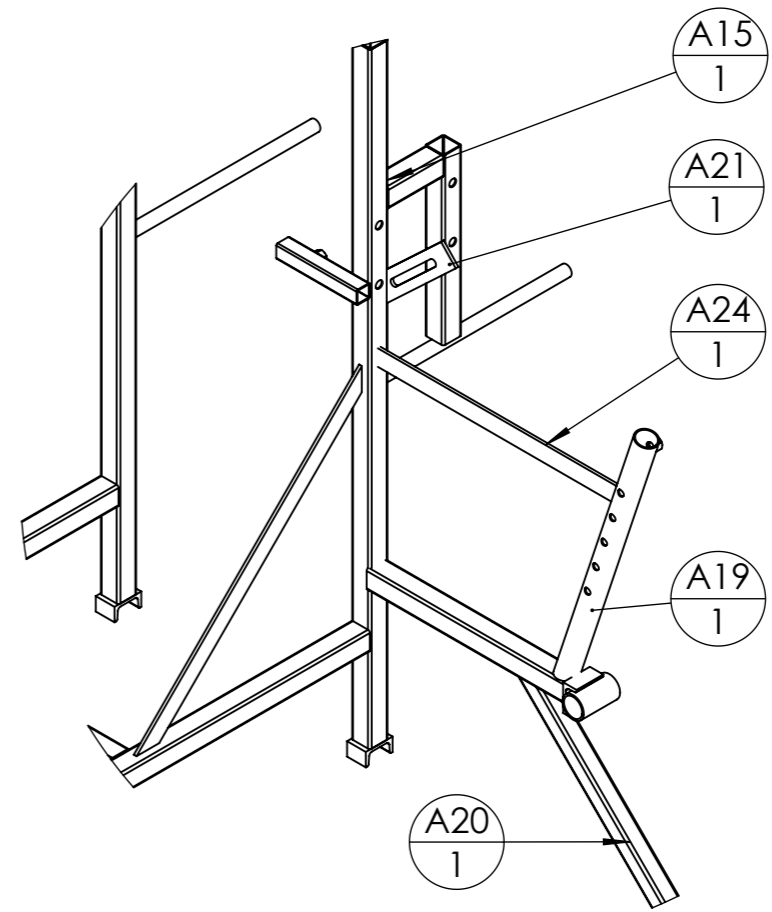



Outil	dérouleuse enrouleuse textile				
Date	05/10/2020	Version	0.5		page n° 9 / 11
Pièce	Point de vigilance		Qté		1



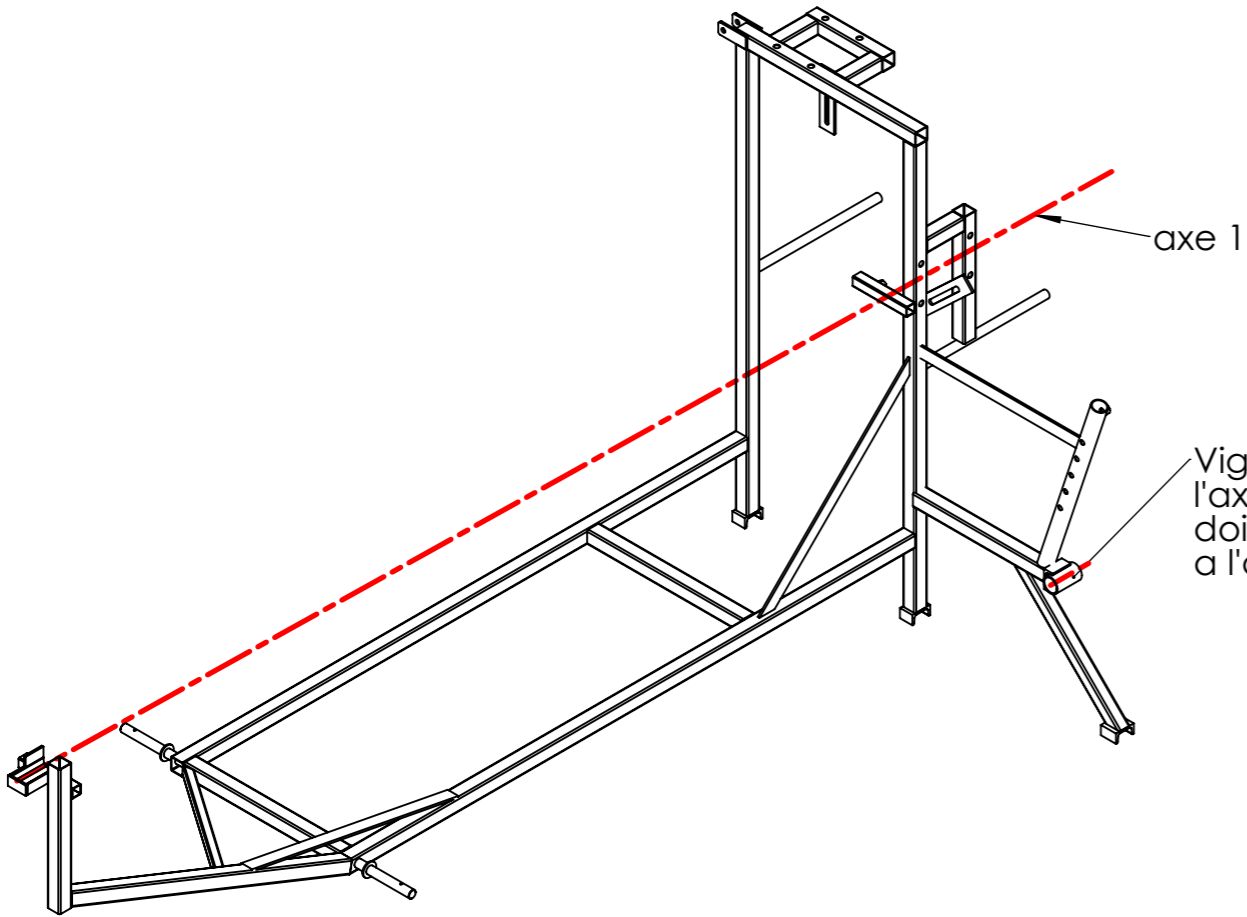
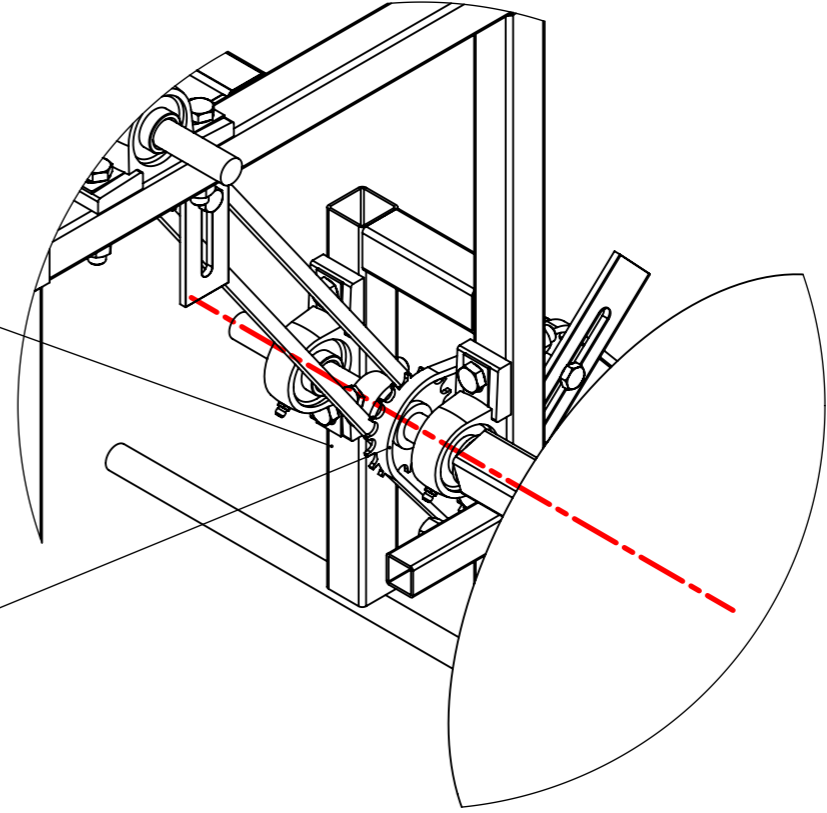
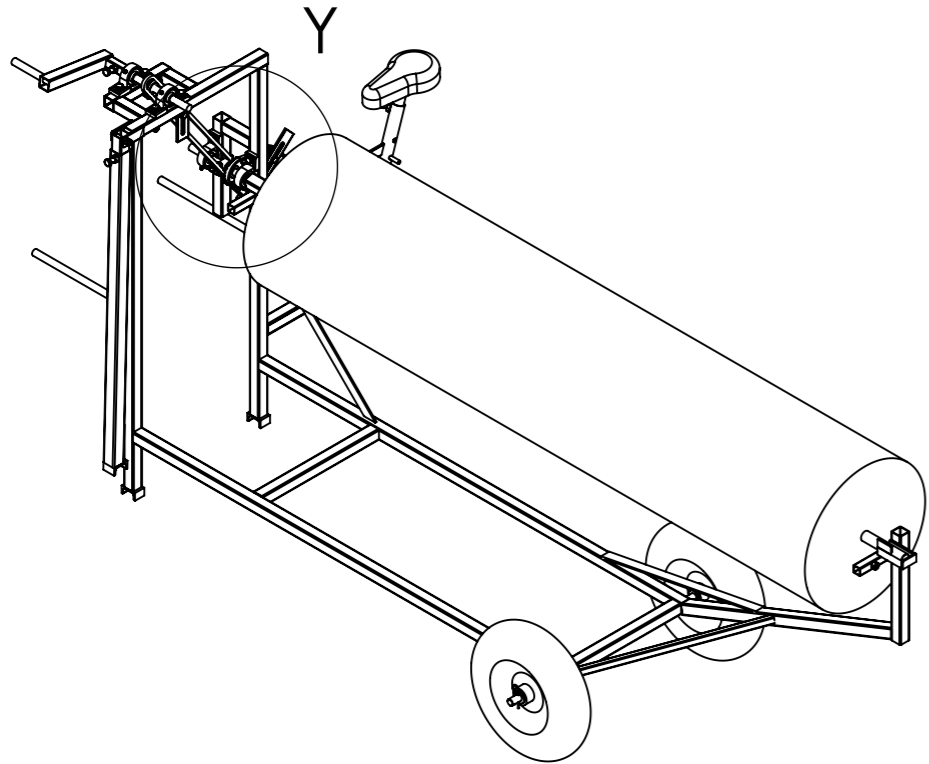

il faut que les trous de cette barre soient aligner avec les trous de la barre de gauche afin que l'alignement de l'axe soit bon

Le pignon libre doit être monté dans le bon sens et dans l'alignement du plateau

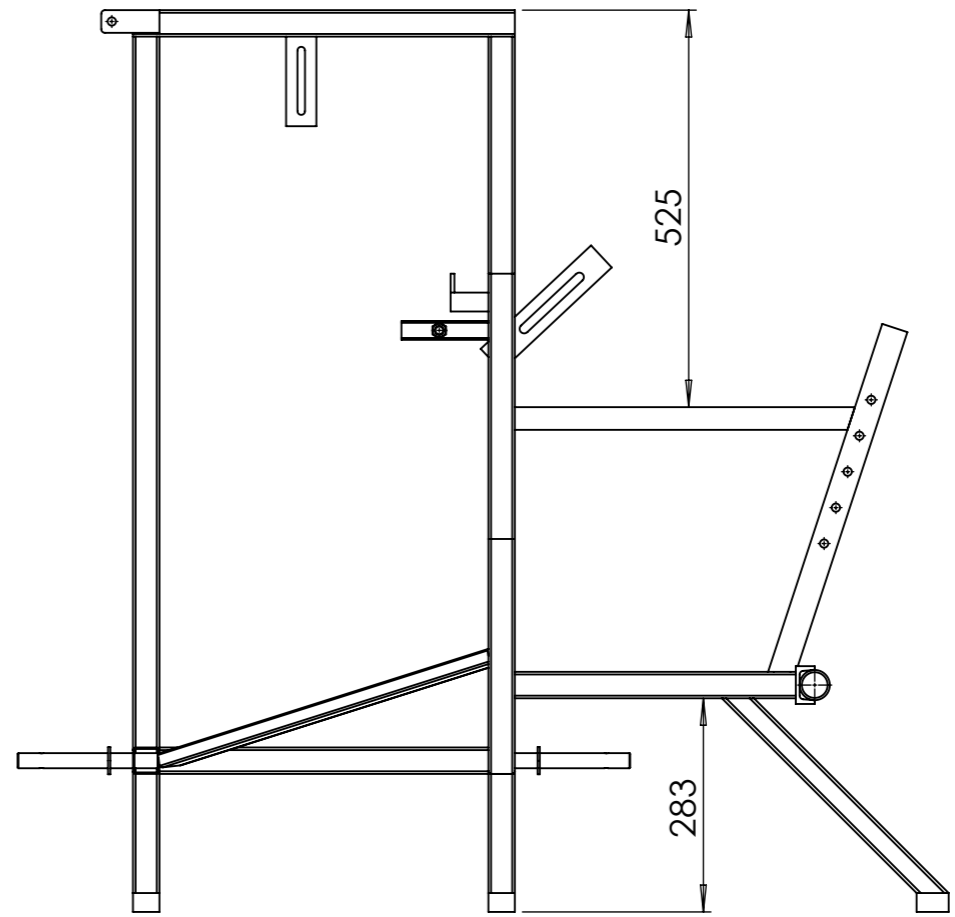

Vigilance soudure : l'axe du pédalier doit être parallèle à l'axe 1 !



Outil	dérouleuse enrouleuse textile				
Date	05/10/2020	Version	0.5		page n° 10 / 11
Feuille	Fournitures globales vélo				



repère	Désignation	ANGLE1	ANGLE2	p	LONGUEUR	Quantité
Vis Hexagonale	Vis hexagonale M12 x 30					1
tendeur simple 15 dents	tendeur simple 08B1					1
selle	selle + tige velo 26mm					1
boitier de pedalier bsa 110-68-un26	Boitier de pédalier					1
pédalier droit	Pédalier					1
pédale	Pédales BMX					2
chaîne	Chaîne à rouleau, 08B1, 1,4m					1
Vis Hexagonale	vis hexagonale M10 x 70					1
A17	tube carré 35 x 2	0.00	0.00		375	1
A18	Fer U 50 x 25 x 5	0.00	0.00		50	1
A19	tube rond 35 x 2	18.17	0.00	1x Ø31 ; 1x Ø13 ; 10x Ø11 ;	484	1
A20	Tube carré 30 x 2	45.00	45.00		394	1
A21	fer plat 40 x 5	0.00	0.00		200	1
A24	Fer plat 30 x 5	0.00	-		454	1
A28	Moyeu pédalier					1
A29	Ecrou M12 brut					1
A30	Fer U 50 x 25 x 5	0.00	0.00		42	1

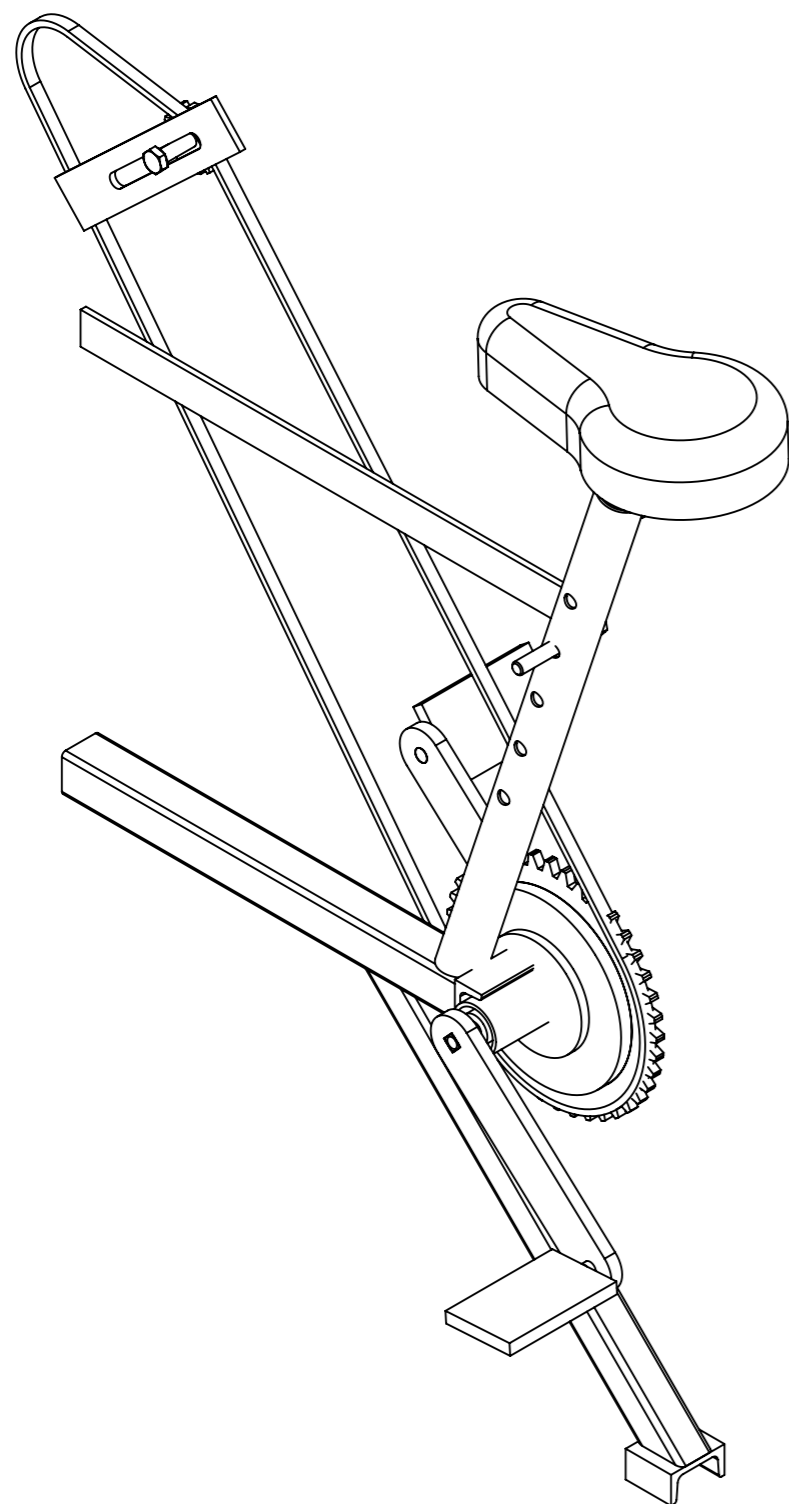

Outil	dérouleuse enrrouleuse textile				
Date	05/10/2020	Version	0.5		page n° 11 / 11
Pièce	Contributions		Qté		1



Les travaux pour réaliser la présente mise à jour ont bénéficié d'une contribution des collectivités publiques :



Cette mise à jour, comme les précédentes, a bénéficié de la contribution bénévole et décisive des nombreux(es) paysan(ne)s, membres formels ou informels du collectif L'Atelier paysan. Nottament Romuald Botte et Francis Aymonier, tout deux maraichers friands d'innovation et d'ergonomie.

