

Outil	dérouleuse enrouleuse textile				
Date	05/10/2020	Version	0.5	page n° 1 / 11	
Pièce	Préambule			Qté	

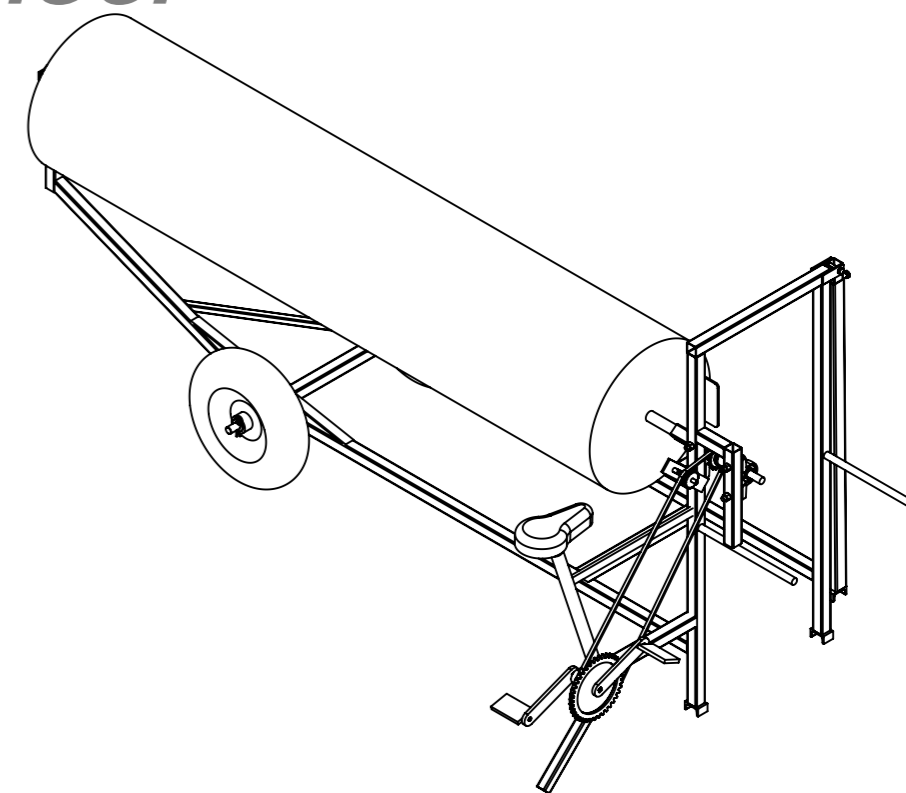

Avant de commencer



La présente version est le résultat des évolutions par l'usage, d'expérimentations paysannes quotidiennes, des ajustements pratiques issus des retours des participants aux nombreuses formations et journées de terrain collectives.

L'autoconstruction de votre outil à l'aide de ce tutoriel n'est que le début de votre aventure. Si cette machine est pertinente en l'état pour de nombreux contextes, vous allez devoir l'adapter, la régler, la modifier pour l'ajuster à votre projet agronomique, vos itinéraires techniques, vos conditions pédo-climatiques. Vous allez donc faire vivre cette machine.

Merci de nous faire parvenir vos retours, vos découvertes, vos réussites. Vos expériences individuelles, vos tâtonnements de terrain viendront enrichir le pot commun paysan, sous même licence libre que les présents plans.

<http://www.latelierpaysan.org/>



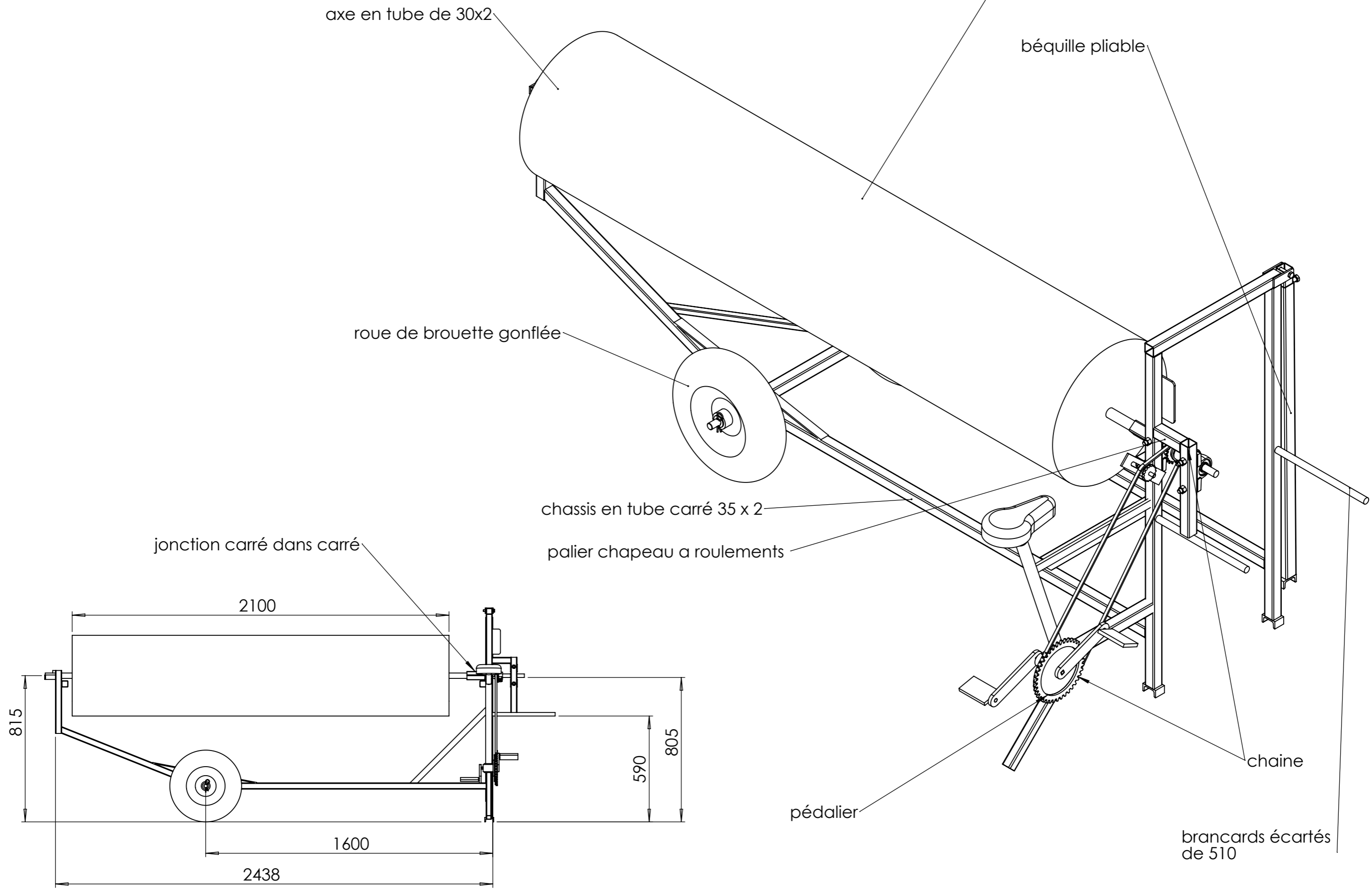

<http://forum.latelierpaysan.org>

Outil	dérouleuse enrouleuse textile				L'atelier paysan
Date	05/10/2020	Version	0.5	page n° 2 / 11	
Pièce	présentation			Qté	

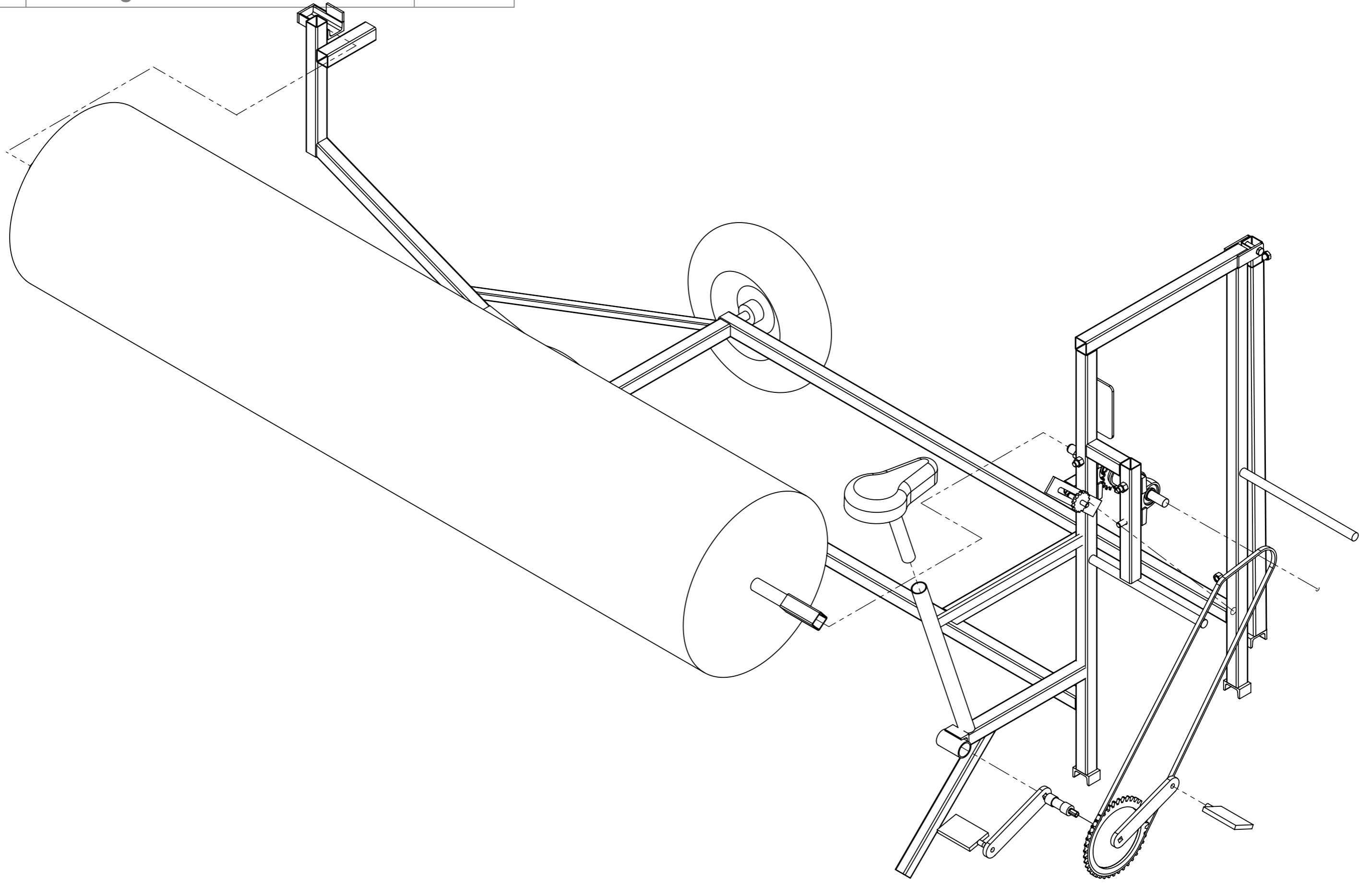

Outil	dérouleuse enrouleuse textile		
Date	05/10/2020	Version	0.5
page n°	3	/ 11	
Feuille	Eclaté général		



Outil	dérouleuse enrouleuse textile				
Date	05/10/2020	Version	0.5		page n° 4 / 11
Feuille	Encombrement				

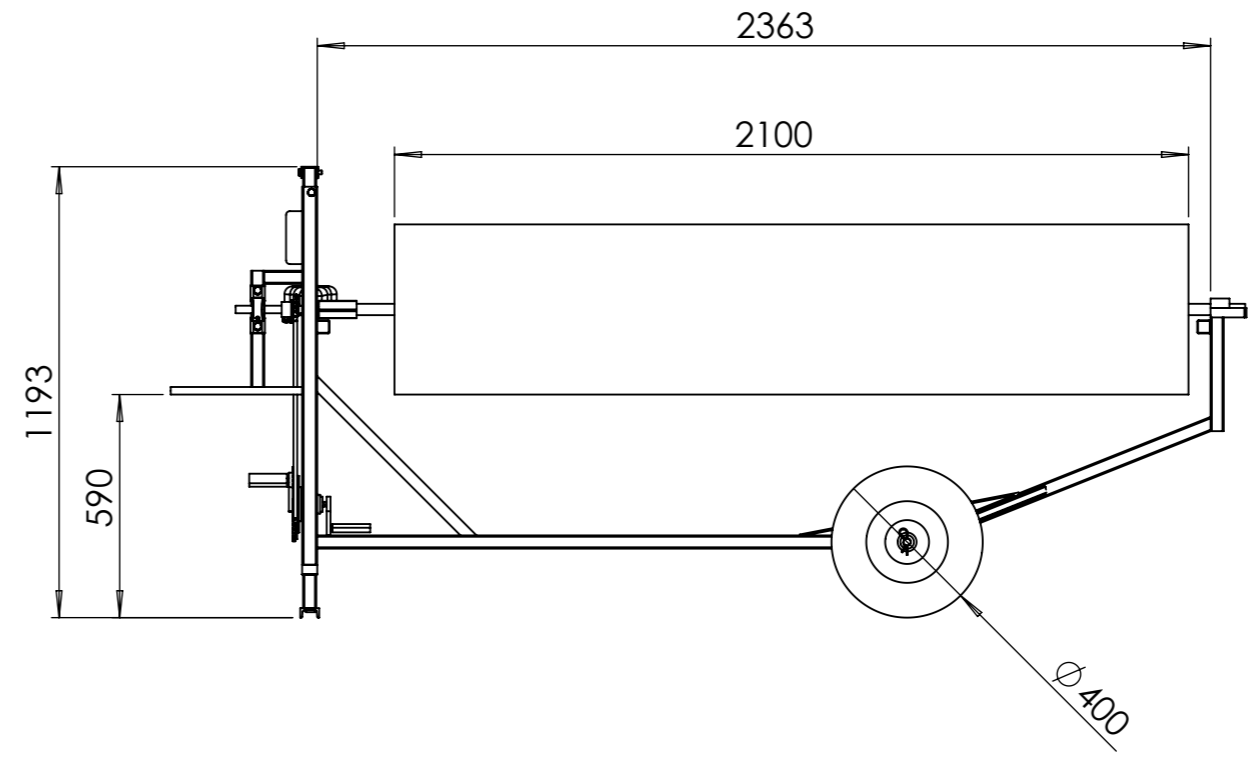
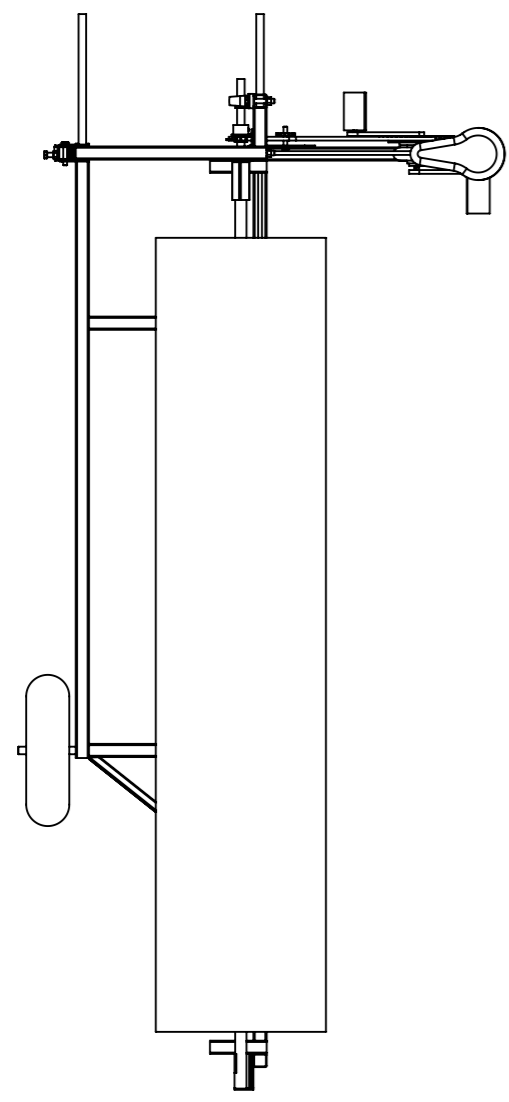
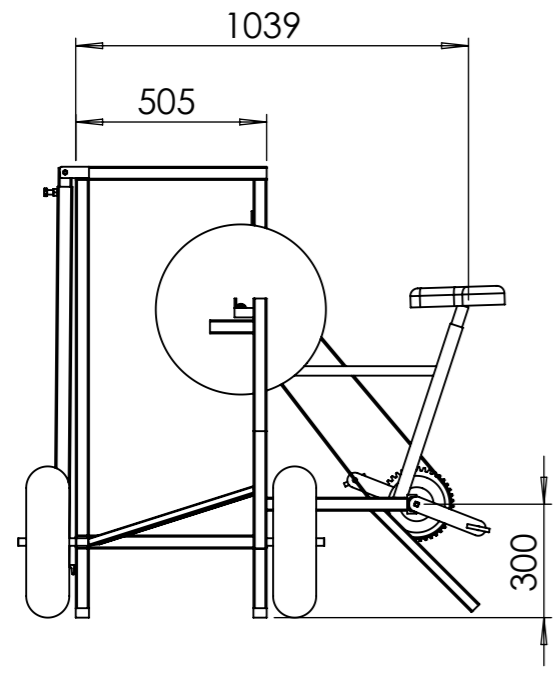

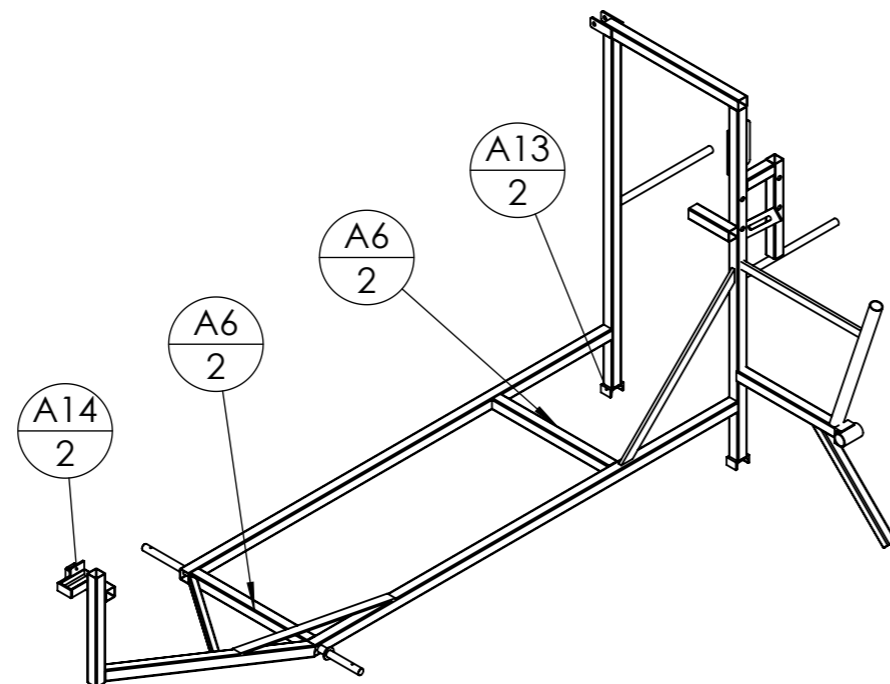
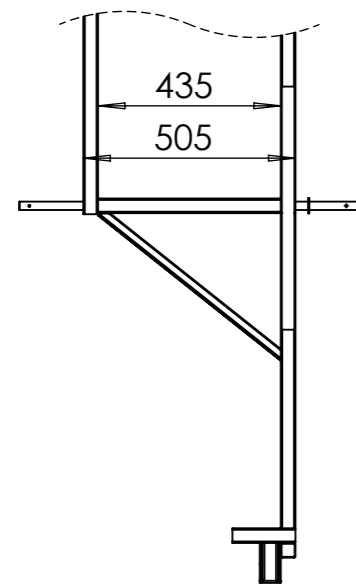
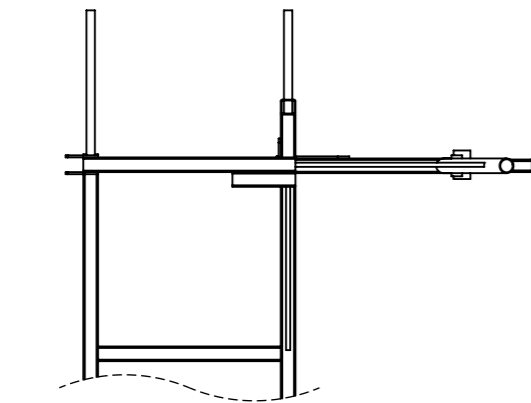
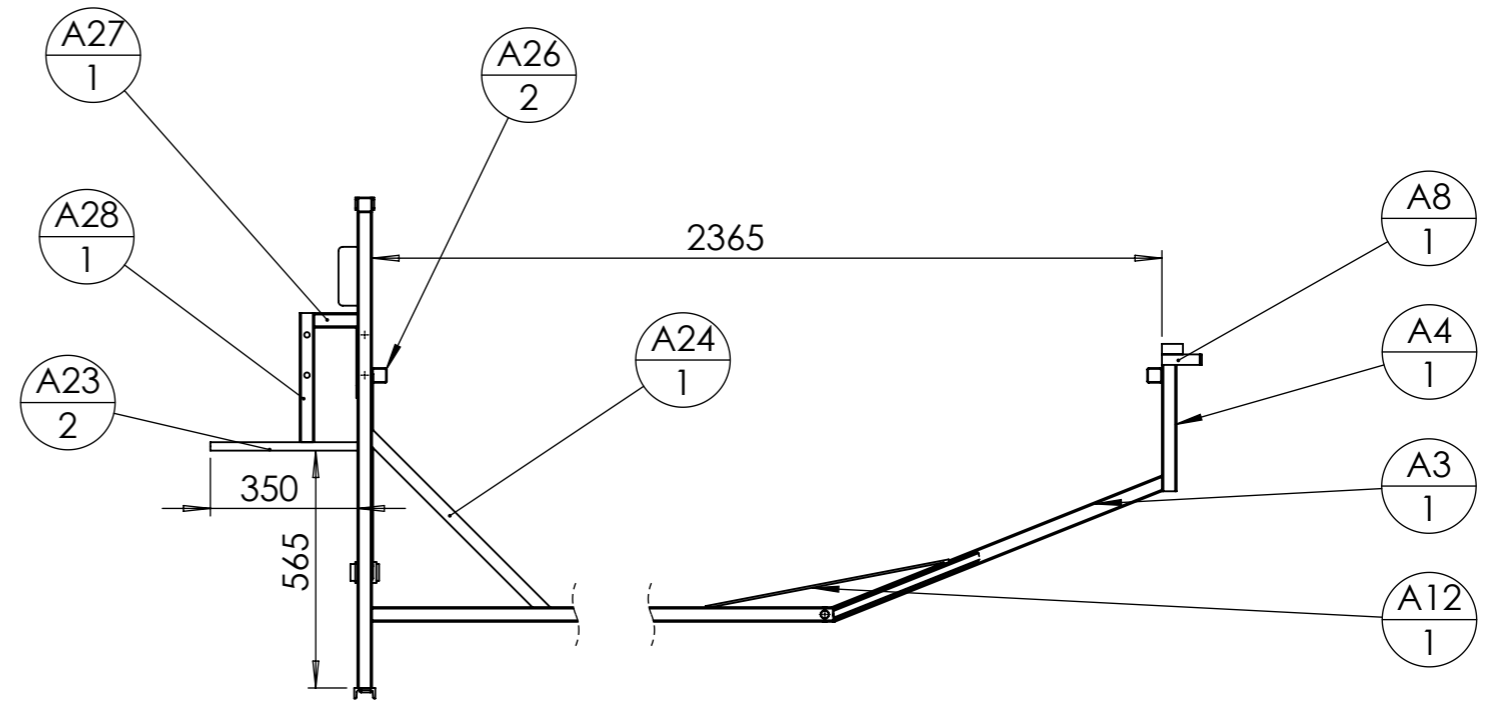
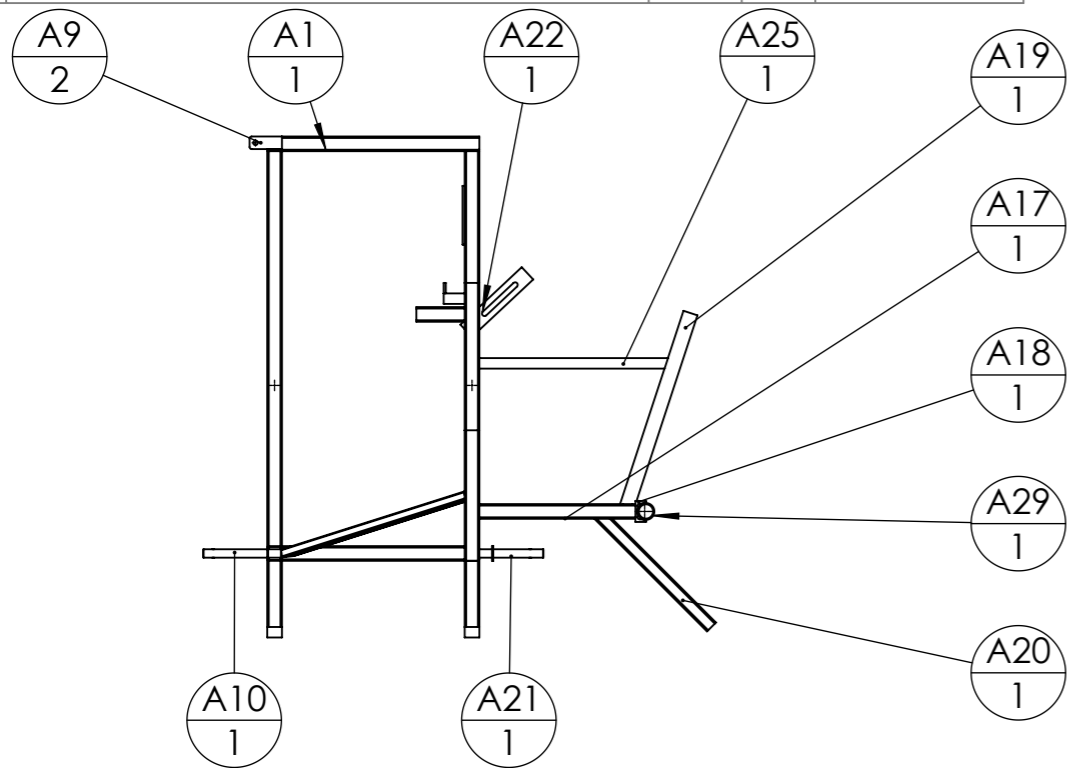

rep	Désignation	ANGLE1	ANGLE2	p	Long.	Qté
A1	tube carré 35 x 2	0.00	0.00		505	1
A2	tube carré 35 x 2	10.87	0.00	1x Ø20 ;	1586	1
A3	tube carré 35 x 2	21.74	10.87		853	1
A4	tube carré 35 x 2	0.00	0.00		351	1
A5	tube carré 35 x 2	0.00	0.00	1x Ø20 ;	1583	1
A6	tube carré 35 x 2	0.00	0.00		435	2
A7	tube carré 35 x 2	0.00	0.00		1133	1
A8	Fer U 50 x 25 x 5	0.00	0.00		90	1
A9	Fer plat 30 x 5	0.00	0.00	1x Ø11 ;	77	2
A26	tube carré 35 x 2	0.00	0.00		150	2
A11	Tube carré 20 x 2	0.00	-		574	1
A12	Fer plat 30 x 5	0.00	0.00		589	1
A13	Fer U 50 x 25 x 5	0.00	0.00		35	2
A14	Fer plat 50 x 5	0.00	0.00		25	2
A15	Fer plat 80 x 5	0.00	0.00		140	1
A16	étiré rond Ø20	-	-	1x Ø20 ;	0	1
A17	tube carré 35 x 2	0.00	0.00		375	1
A18	Fer U 50 x 25 x 5	0.00	0.00		50	1
A19	tube rond 35 x 2	18.17	0.00	1x Ø31 ;	484	1
A23	étiré rond Ø20	0.00	0.00		350	2
A25	fer plat 25 x 10	0.00	-		454	1
A10	étiré rond Ø20	0.00	0.00	1x Ø5 ;	185	1
A27	tube carré 35 x 2	0.00	0.00		103	1
A20	Tube carré 30 x 2	0.00	45.00		379	1
A21	étiré rond Ø20	0.00	0.00	1x Ø5 ;	185	1
A24	étiré plat 30 x 10	45.00	45.00		599	1
A22	fer plat 40 x 5	0.00	0.00		200	1
A28	tube carré 35 x 2	0.00	0.00	4x Ø13 ;	308	1
A29	Moyeu pédalier					1
A30	tube carré 35 x 2	0.00	0.00	4x Ø13 ;	1133	1

Outil	dérouleuse enrouleuse textile				
Date	05/10/2020	Version	0.5		page n° 6 / 11
Pièce	Pièce du A		Qté		1



ATTENTION ERGONOMIQUE : la position des platines A20 supérieures (celles pour la manivelle) peut être ajustée en fonction de la taille de l'opérateur-trice. Ces platines peuvent être soudées verticalement (comme les 2 autres) sur les montants A1 et A9 : à la hauteur souhaitée.

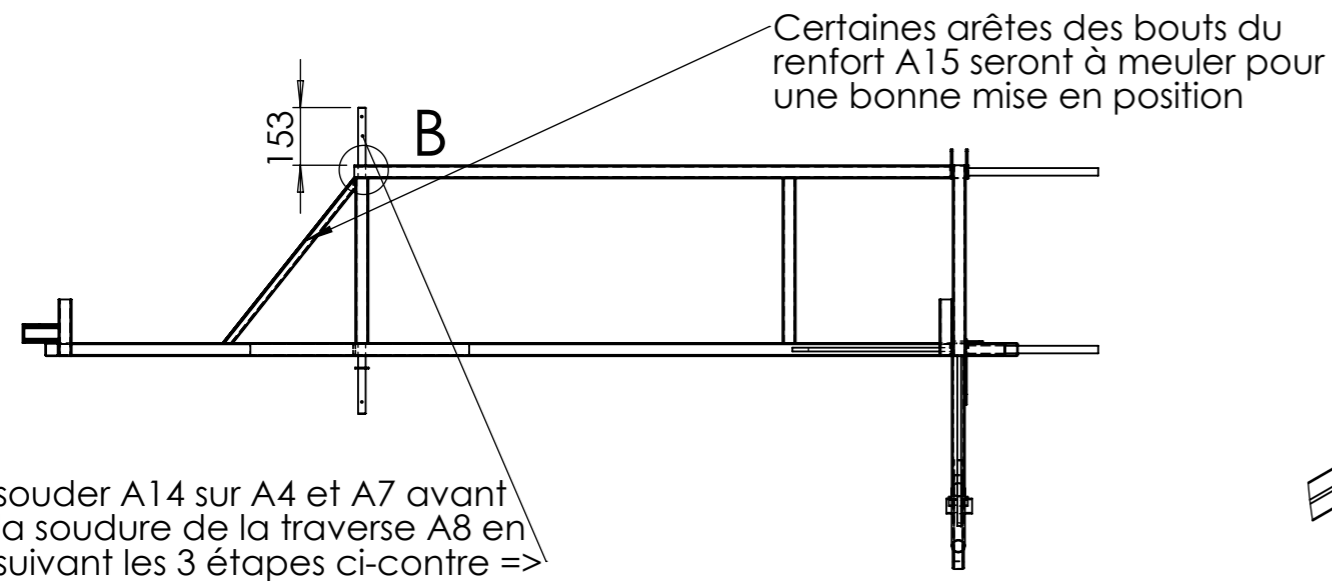
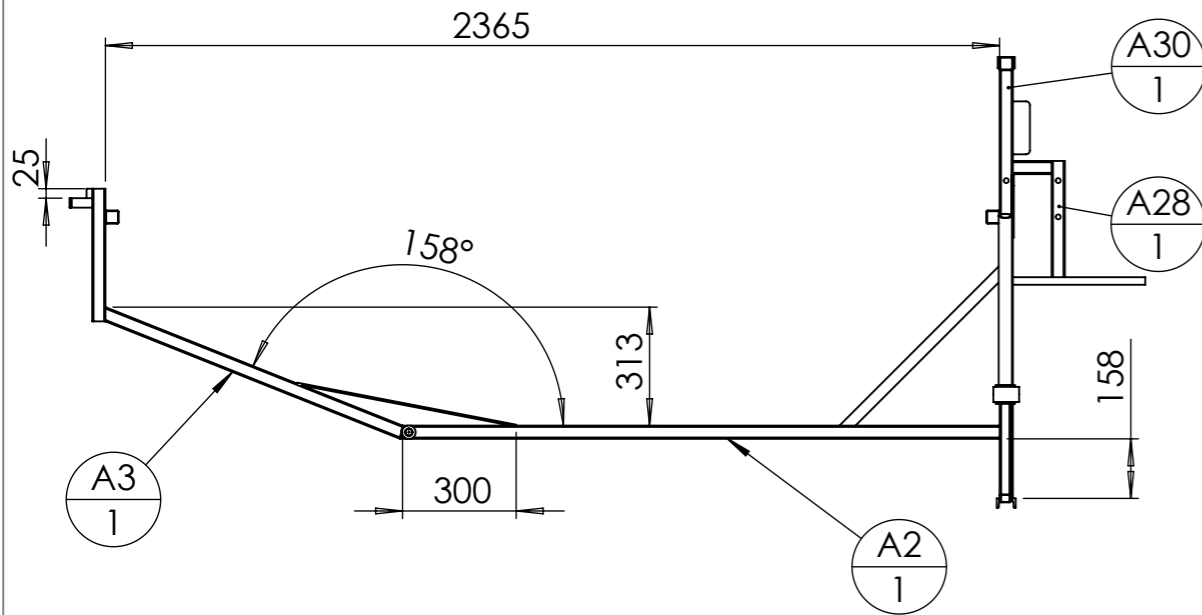

souder A14 sur A4 et A7 avant la soudure de la traverse A8 en suivant les 3 étapes ci-contre =>

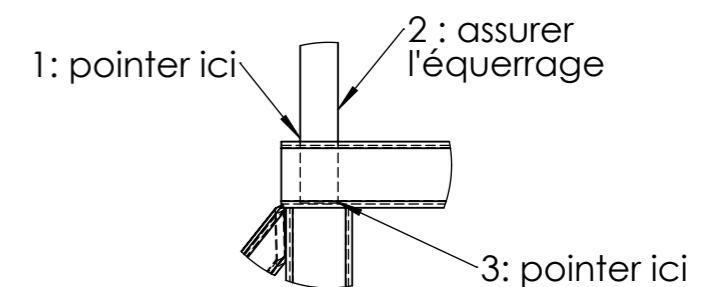
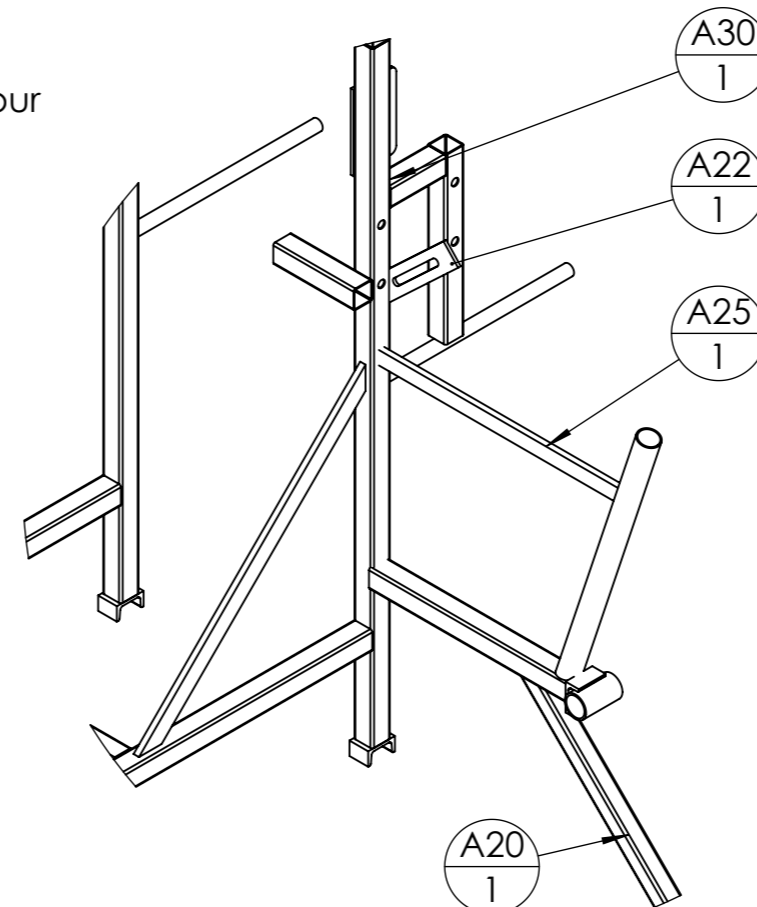
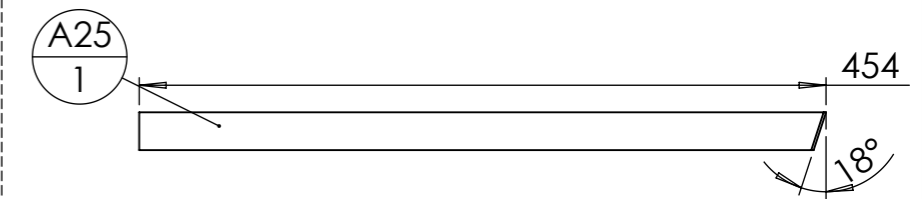
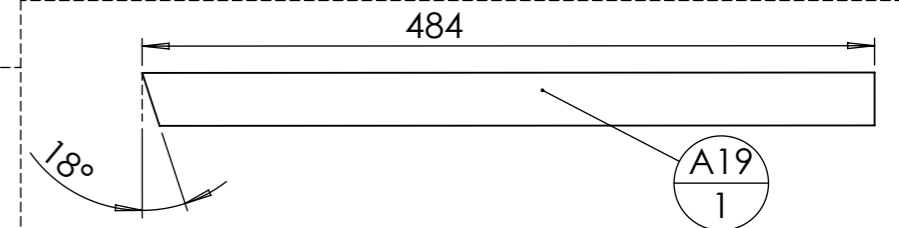
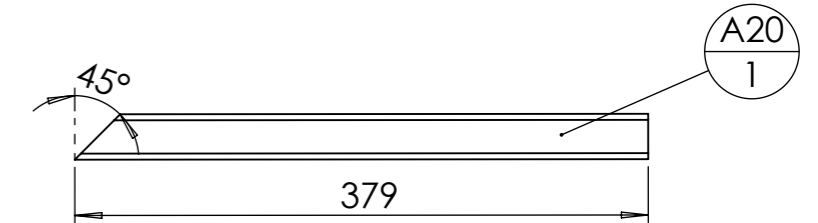
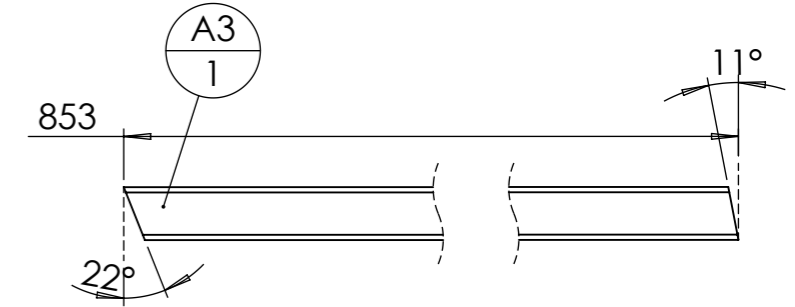
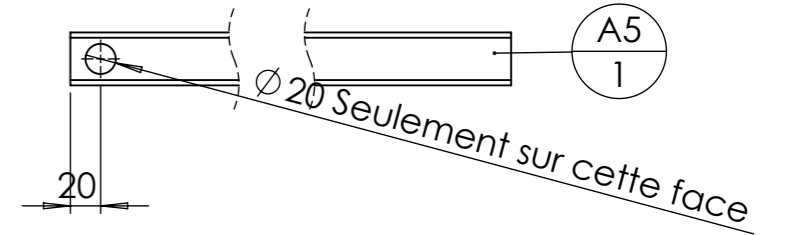
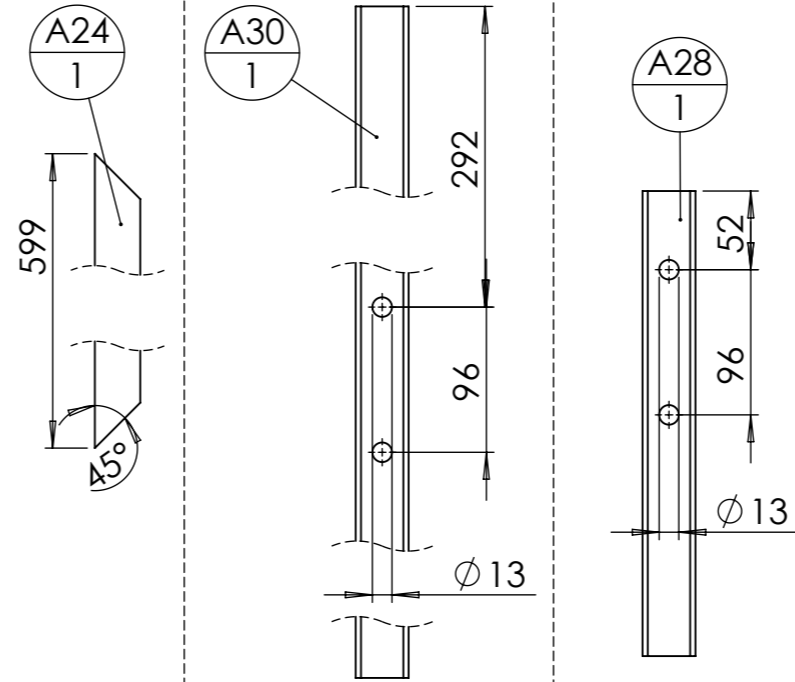

DÉTAIL B

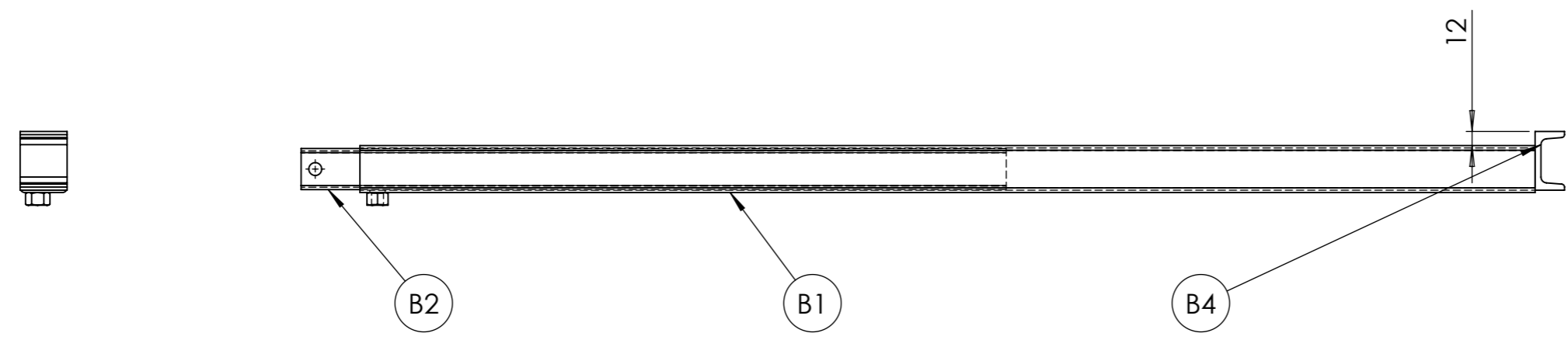
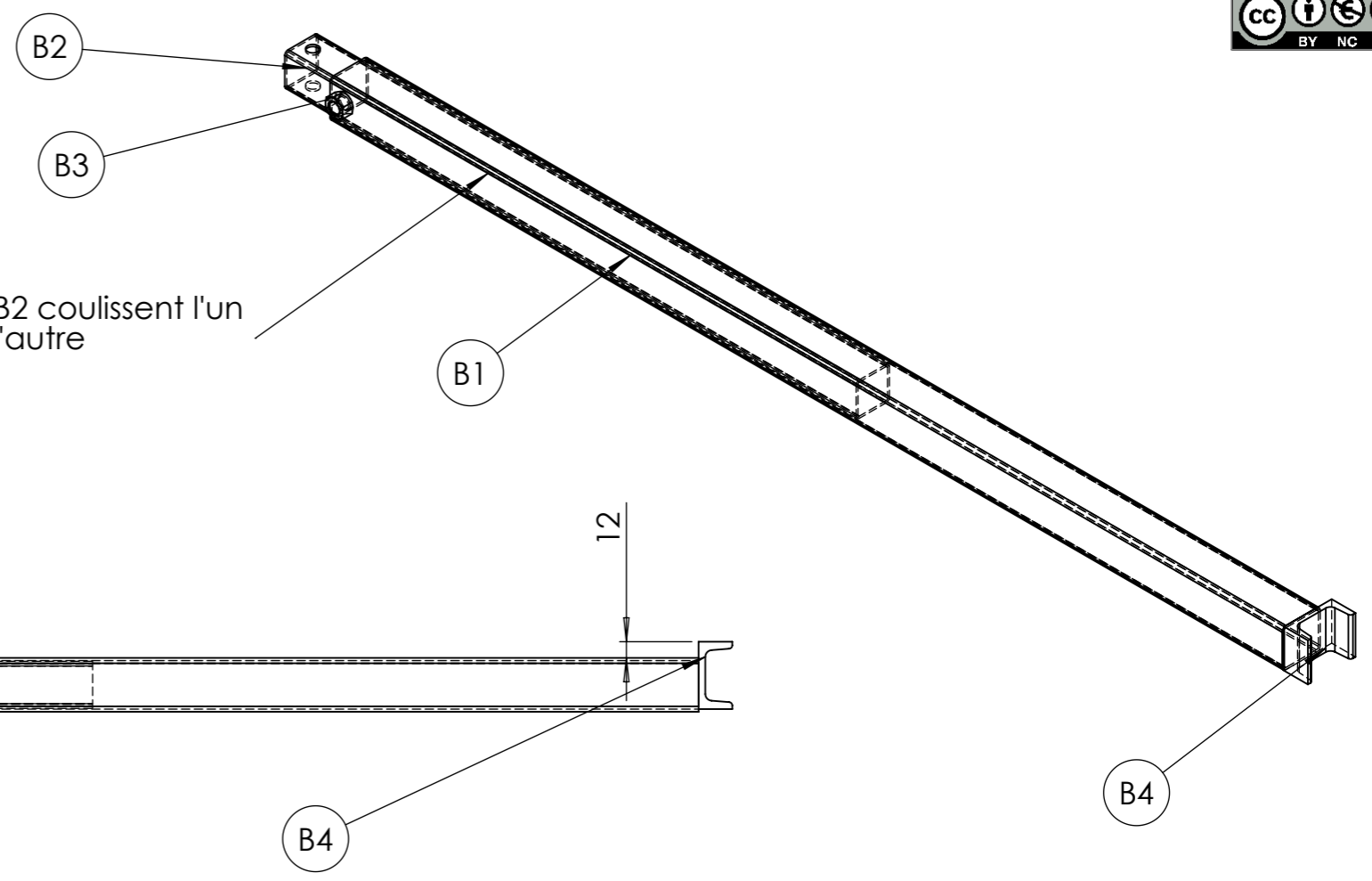

repère	Désignation	ANGLE1	ANGLE2	p	LONGUEUR	Quantité
B1	tube carré 40 x 2	0.00	0.00	1x Ø13 ;	1000	1
B2	tube carré 35 x 2	0.00	0.00	2x Ø11 ;	600	1
B3	Ecrou M12 brut					1
B4	Fer U 50 x 25 x 5	0.00	0.00		40	1

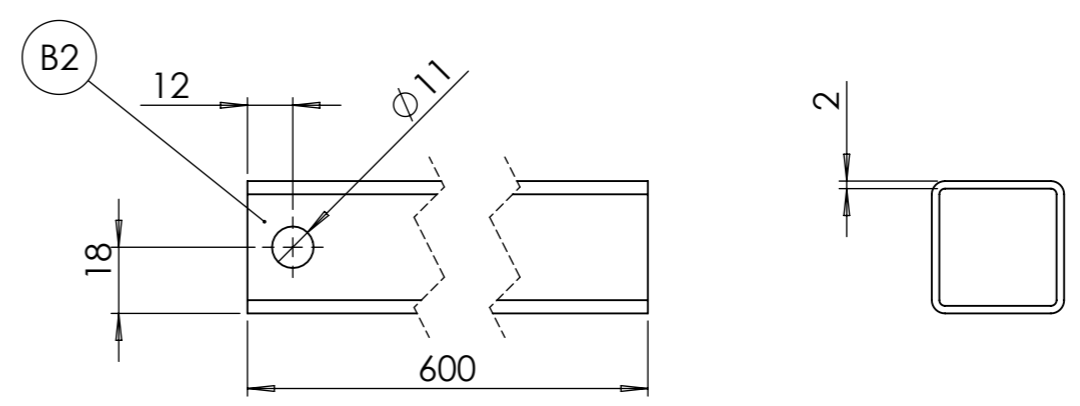
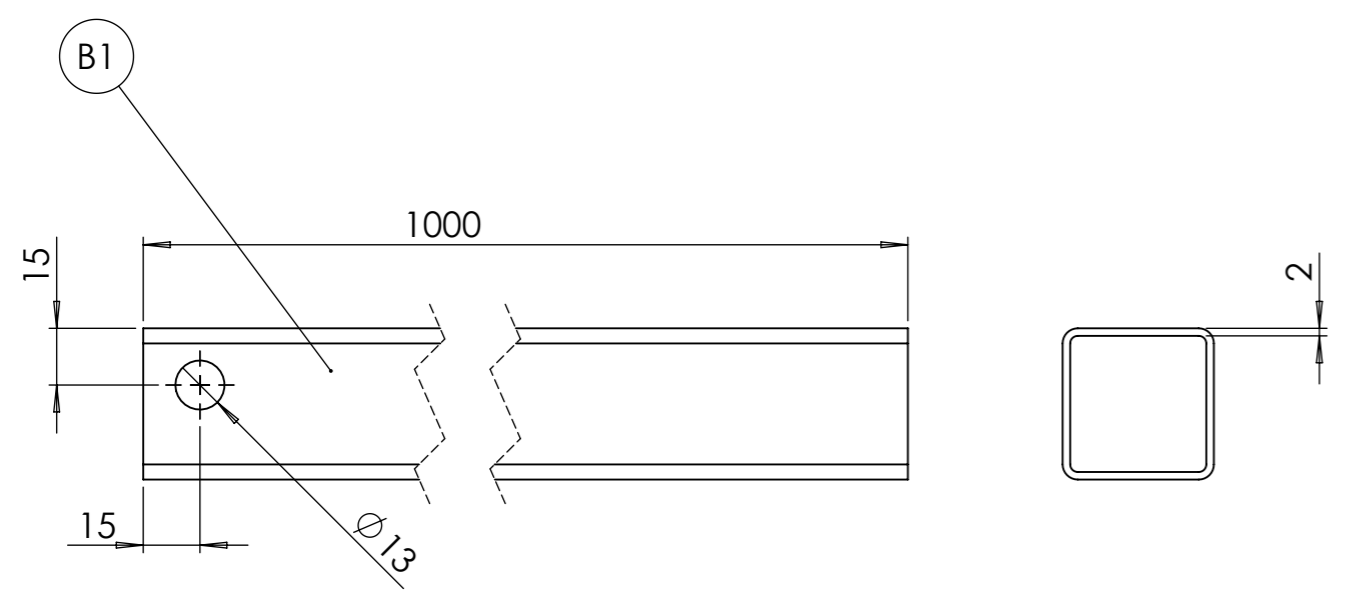

Outil	dérouleuse enrouleuse textile			L'atelier paysan	
Date	05/10/2020	Version	0.5		page n° 8 / 11
Pièce	autres		Qté		1

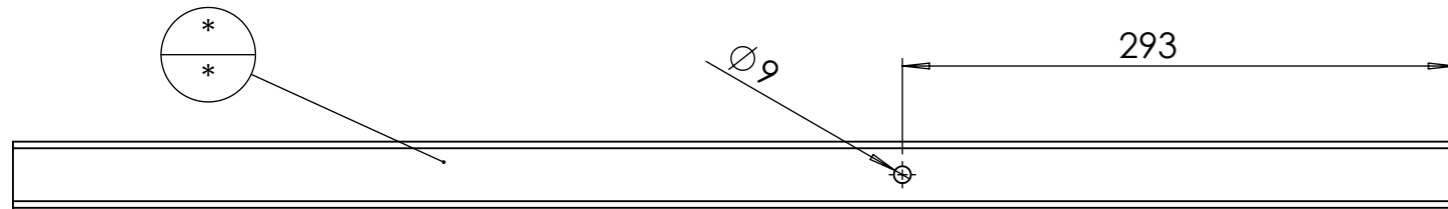
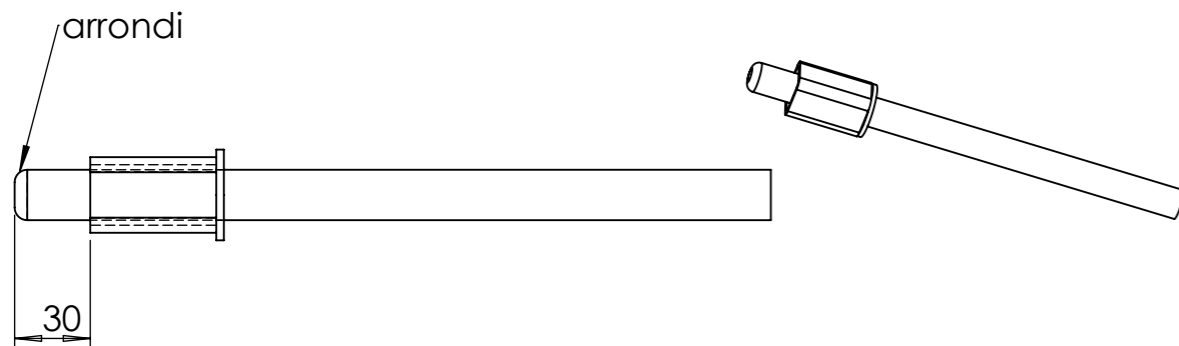

Table de nomenclature(restructuré)

N°	Désignation	Longueur	Qté
	tube carré 35 x 2	763	1

Repère	Désignation	Longueur	Qté
C1	étiré rond Ø20	300	1
C	tube carré 30 x 3	50	1
rondelle	Rondelle Ø20 série ZU		1



rep	Désignation	ANGLE1	ANGLE2	p	Long.	Qté
R1	tube rond 30 x 2	0.00	0.00		2400	1
R2	tube carré 35 x 2	0.00	0.00		100	1

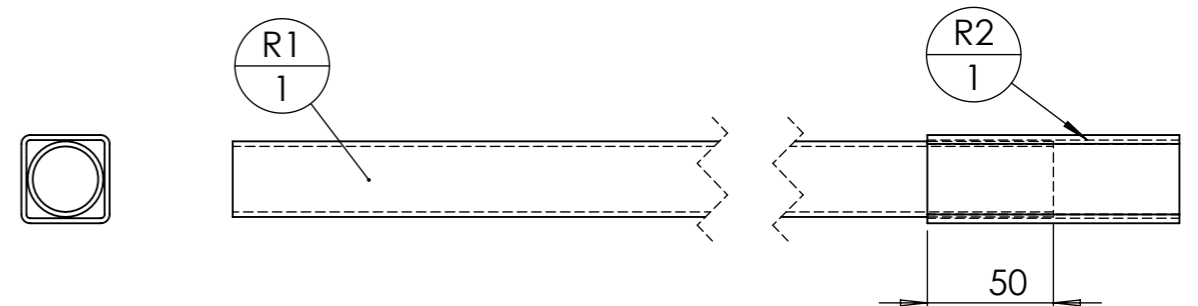

Outil	dérouleuse enrouleuse textile			
Date	05/10/2020	Version	0.5	page n° 9 / 11
Feuille	Fournitures globales			

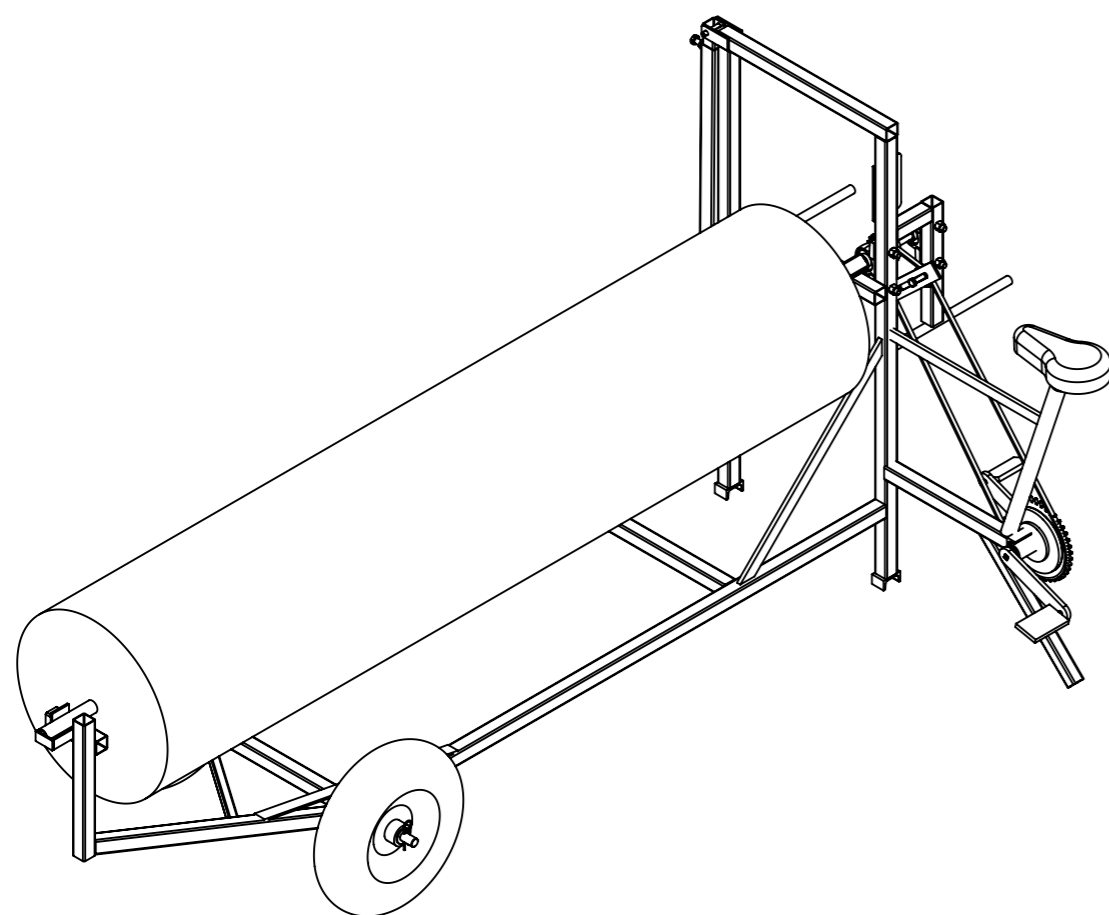

repère	Désignation	ANGLE1	ANGLE2	p	LONGUEUR	Quantité
Palier chapeau Ø20 - UCP204GP	Palier chapeau Øint20					
Vis Hexagonale	vis hexagonale M10 x 55					
Vis Hexagonale	Vis hexagonale M12 x 30					1
Vis Hexagonale	Vis hexagonale M12 x 70					4
Ecrou	Ecrou M12 autofreiné					4
roue_brouette	Roue brouette 400x100 axe 20 mm					2
Rondelle	Rondelle Ø20 série ZU					2
Goupille épingle d'axe, 15x70 Ø4	Goupille épingle d'axe 15x70 Ø4					2
boitier de pedaliar bsa 110-68-un26	Boitier de pédalier					1
chaîne	Chaîne à rouleau, 08B1, 1,4m					1
adapt_cassetteA	Adaptateur cassette Ø33-Øint20					1
Vis Hexagonale	Vis hexagonale M10 x 20					1
SWE121510	SWE121510 Tendeur simple					1
demi_maillon	Demi-maillon de chaîne 08B1					1
B1	tube carré 40 x 2			1x Ø13 ;		1
B2	tube carré 35 x 2			2x Ø11 ;		600
B3	Ecrou M12 brut					1
B4	Fer U 50 x 25 x 5					40
C1	étiré rond Ø20					300
C	tube carré 30 x 3					50
rondelle	Rondelle Ø20 série ZU					1
R1	tube rond 30 x 2					9600
R2	tube carré 35 x 2					400
A1	tube carré 35 x 2					505
A2	tube carré 35 x 2			1x Ø20 ;		3170
A3	tube carré 35 x 2					853
A4	tube carré 35 x 2					351
A6	tube carré 35 x 2					870
A7	tube carré 35 x 2					1133
A8	Fer U 50 x 25 x 5					90
A9	Fer plat 30 x 5			1x Ø11 ;		154
A10	étiré rond Ø20			1x Ø5 ;		370
A11	Tube carré 20 x 2					574
A12	Fer plat 30 x 5					589
A13	Fer U 50 x 25 x 5					70
A14	Fer plat 50 x 5					50
A15	Fer plat 80 x 5					140
A17	tube carré 35 x 2					375
A18	Fer U 50 x 25 x 5					50
A19	tube rond 35 x 2			1x Ø31 ;		484
A20	Tube carré 30 x 2					379
A22	fer plat 40 x 5					200
A23	étiré rond Ø20					700
A24	étiré plat 30 x 10					599
A25	fer plat 25 x 10					454
A26	tube carré 35 x 2					300
A27	tube carré 35 x 2					103
A28	tube carré 35 x 2			4x Ø13 ;		1441
A29	Moyeu pédalier					1
pédalier droit	Pédalier					1
selle						1
pédale	Pédales BMX					2
Roue libre a visser 1 Vitesse	Roue libre à visser 1 Vitesse					1



Outil	dérouleuse enrrouleuse textile				
Date	05/10/2020	Version	0.5		page n° 10 / 11
Pièce	Contributions		Qté		1



Les travaux pour réaliser la présente mise à jour ont bénéficié d'une contribution des collectivités publiques :



Cette mise à jour, comme les précédentes, a bénéficié de la contribution bénévole et décisive des nombreux(es) paysan(ne)s, membres formels ou informels du collectif L'Atelier paysan. Nottament Romuald Botte et Francis Aymonier, tout deux maraichers friands d'innovation et d'ergonomie.



Outil	dérouleuse enrouleuse textile				
Date	05/10/2020	Version	0.5		page n° 11 / 11
Feuille	Feuille 1				

