

Version 1.0 Qté 1

Date 15/10/2013

Outil Attelage Rapide

Pièce Triangle Femelle

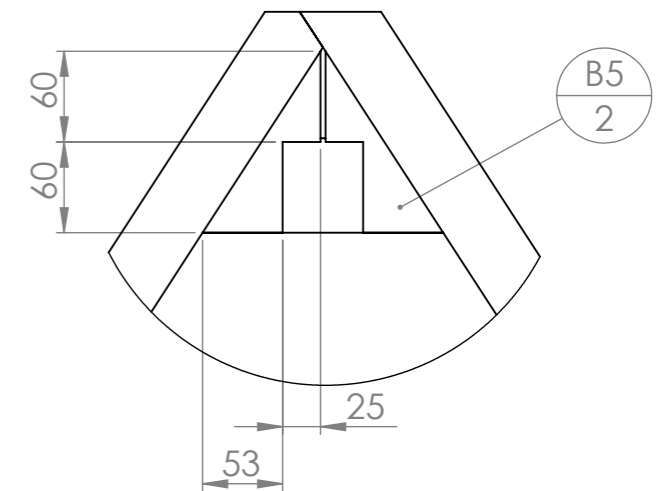
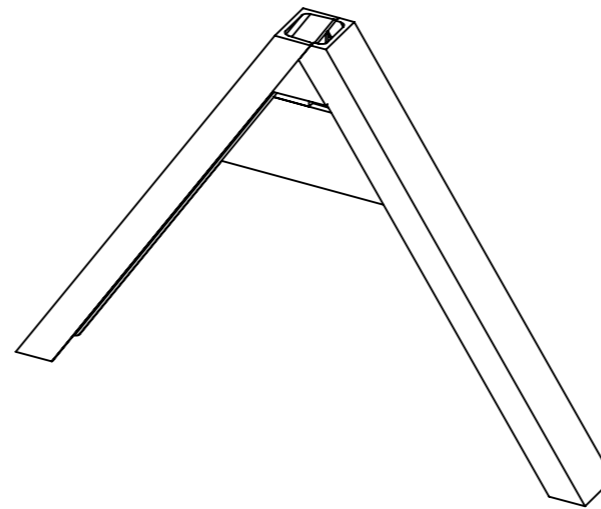
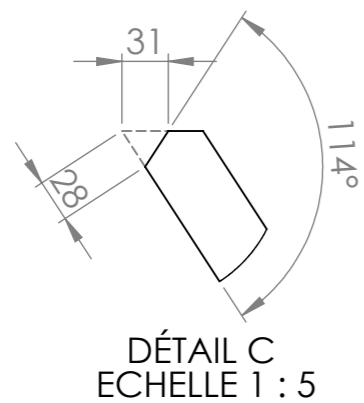
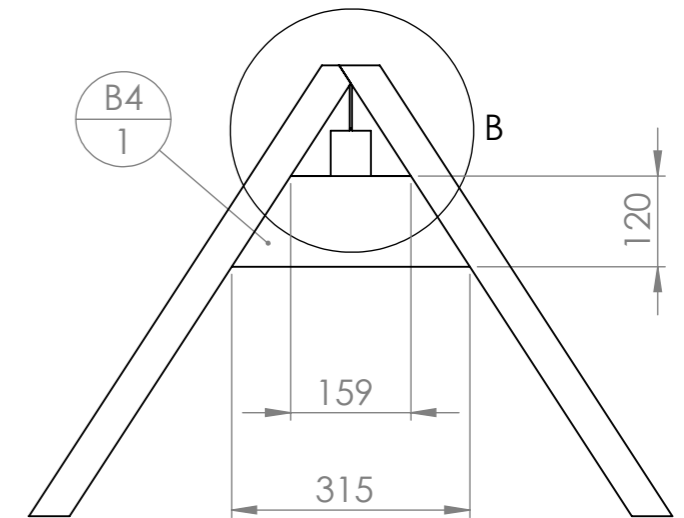
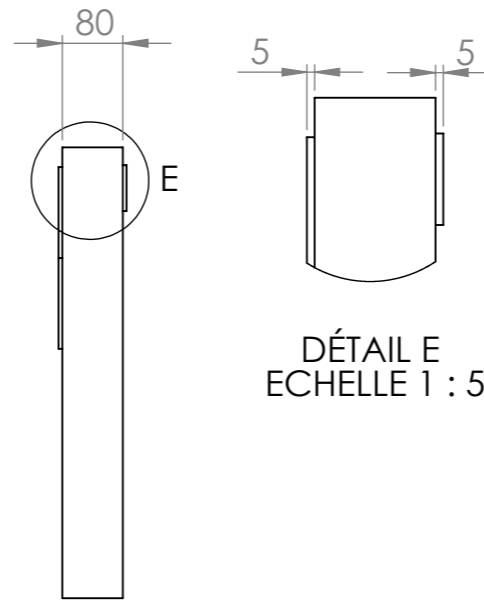
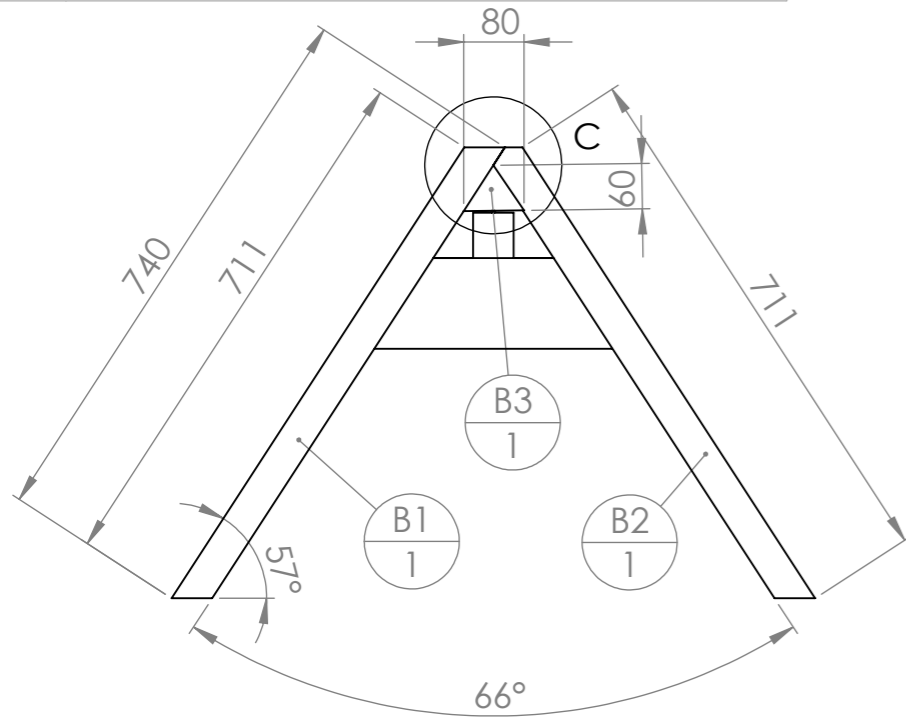

N°	Désignation	Longueur	Qté
B1	Profilé UPN 80 x 45	740	1
B2	Profilé UPN 80 x 45	740	1
B3	Fer plat 120 x 10	80	1
B4	Fer plat 120 x 10	315	1
B5	Fer plat 120 x 10	80	2