

Version	1.1	Qté	1	
Date	8/03/2017			
Outil	Serre Mobile			
Pièce	Serre en T		Page : 1 / 2	

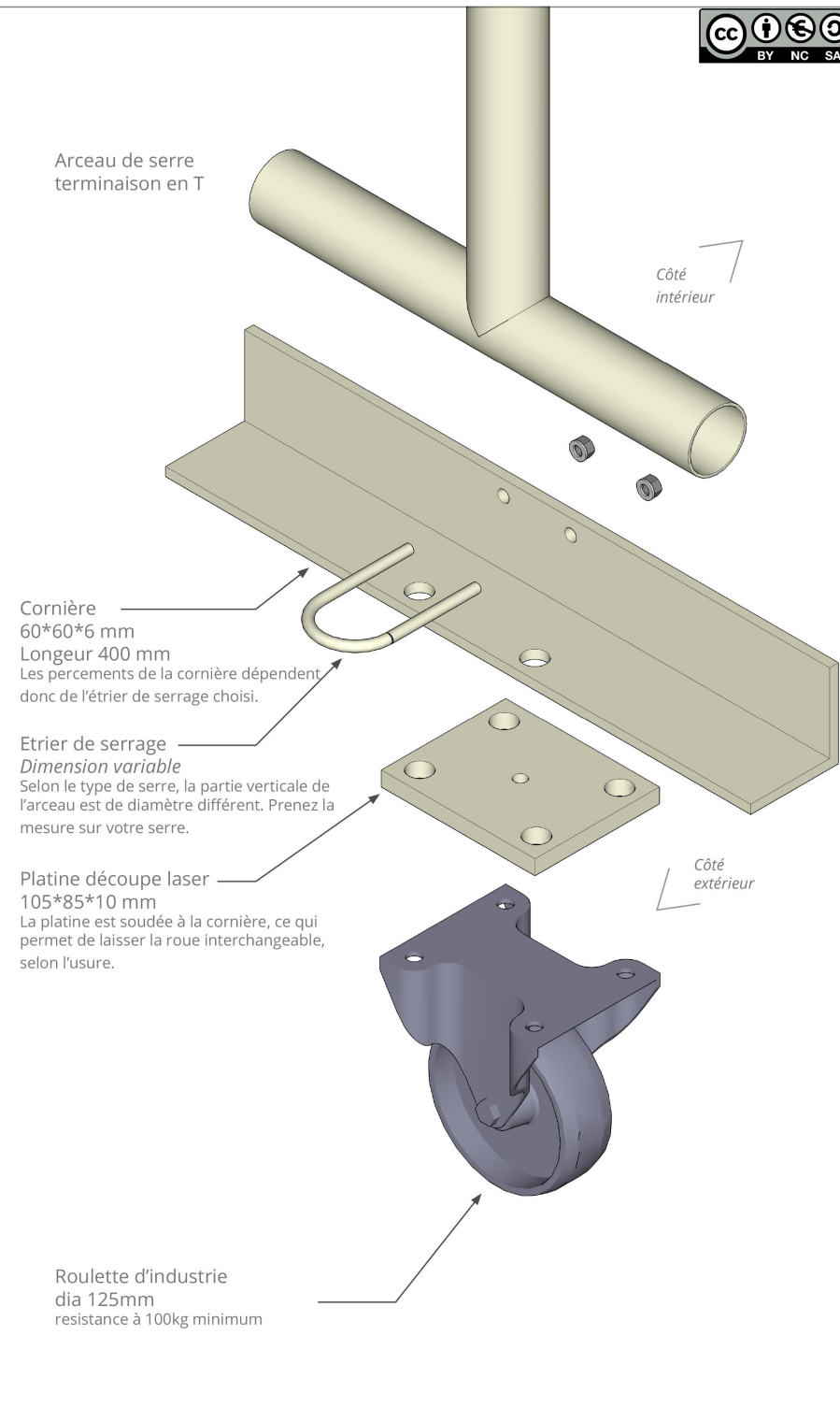

Éléments	pièces	nb	côte
Roulette	Roulette d'industrie	1	dia 125mm
Acier	Platine découpe laser	1	épaisseur 10mm 105*85 mm
	Cornière	1	60*60*6 mm Longeur 400 mm
Quicailleire	Etrier de serrage	1	Dia 6 mm Dimension à adapter selon la serre
	Vis	4	M8*35
	Ecrous rondelles	4	8 ZN

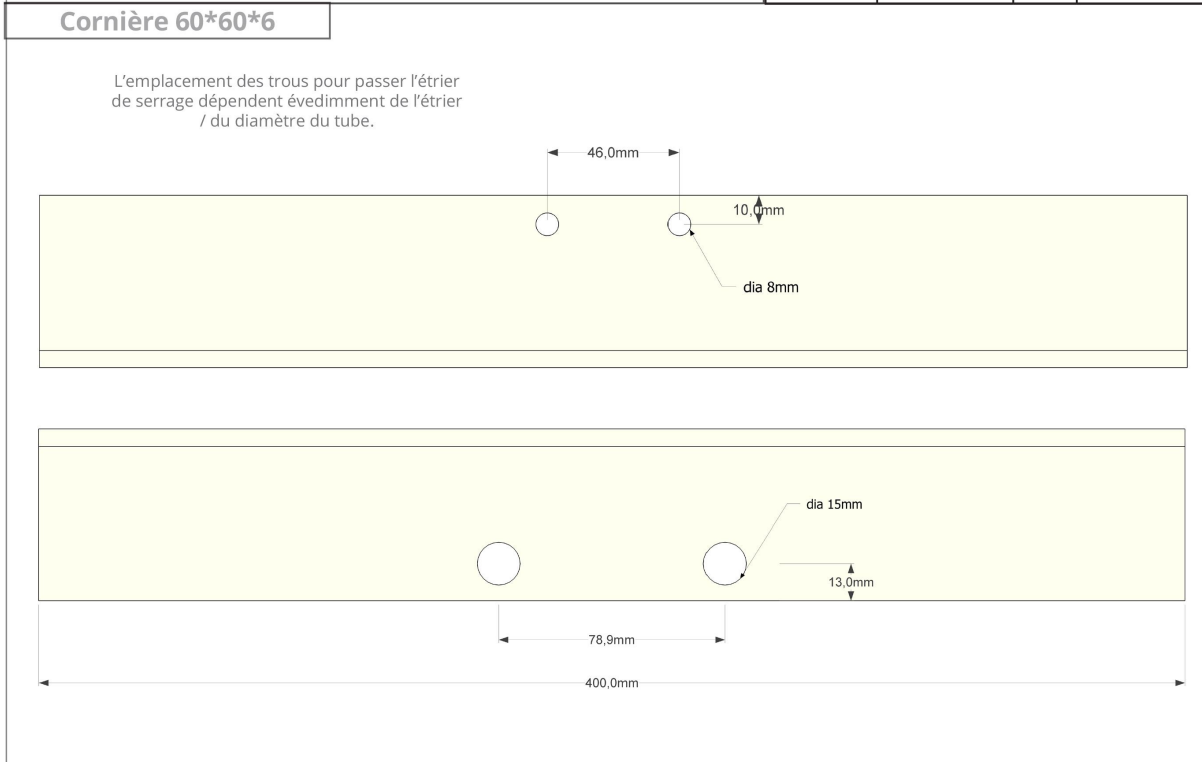
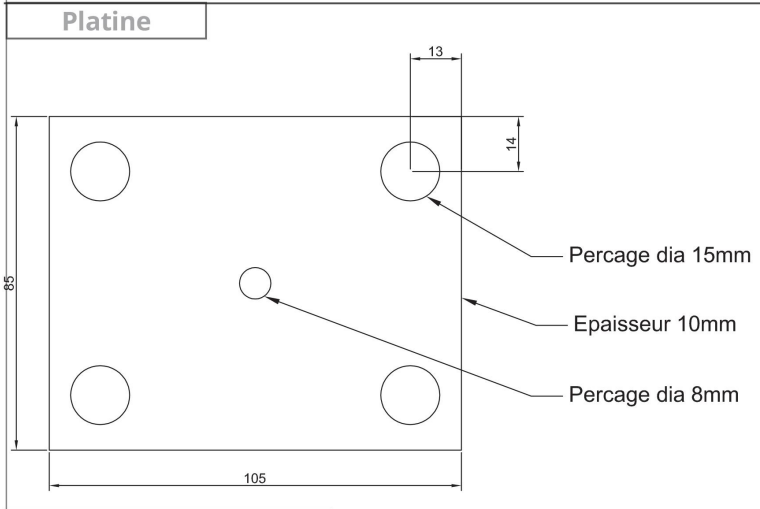

Version	1.0	Qté	1	
Date	8/03/2017			
Outil	Serre Mobile			
Pièce	Serre OVH90		Page : 2 / 2	

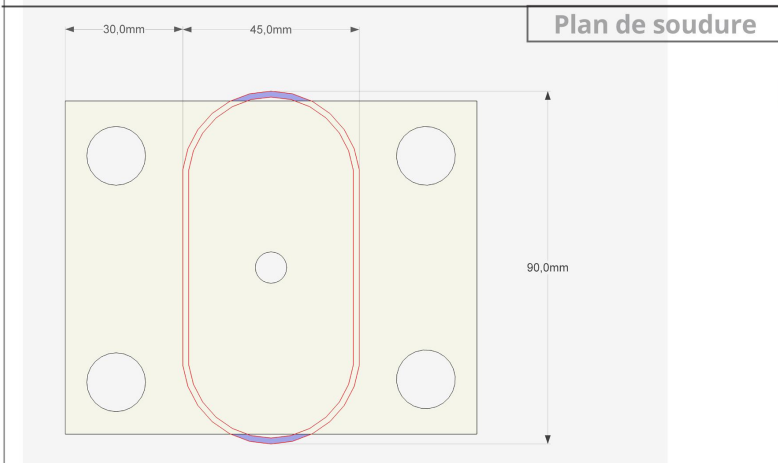
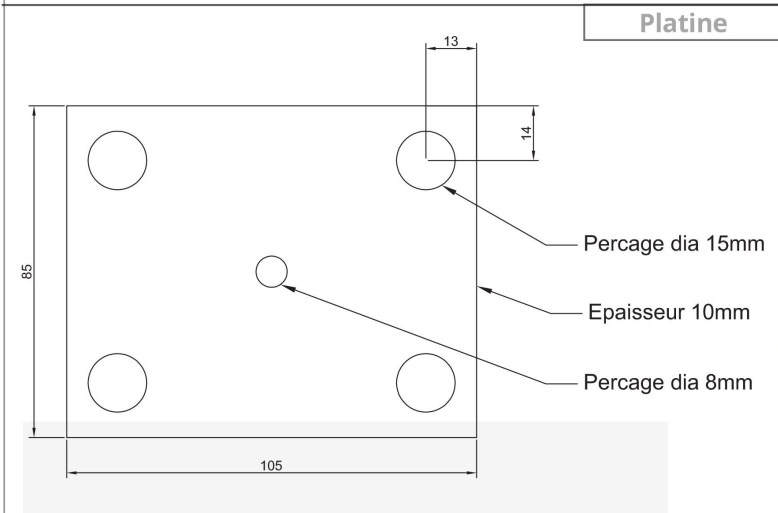

Éléments	pièces	nb	côte
Roulette	Roulette d'industrie	1	dia 125mm
Acier	Platine découpe laser	1	épaisseur 10mm 105*85 mm
	Tube d'emboitement	1	OVH 90*45mm Longeur 100 mm
Quicailleire	Vis autoforeuses	4	M8 4.8*19mm
	Vis	4	M8*35
	Ecrous / rondelles	4	8 ZN

