

C i h	6]bYi gY 'Bfc!D'UbYh		
8 UH	\$) #%&#&\$%*	J Y fg]c b	%"\$ dU[Y 'bš'%'#%+
D], W	J i Y 'XfŷbgYa V'Y	E h	%

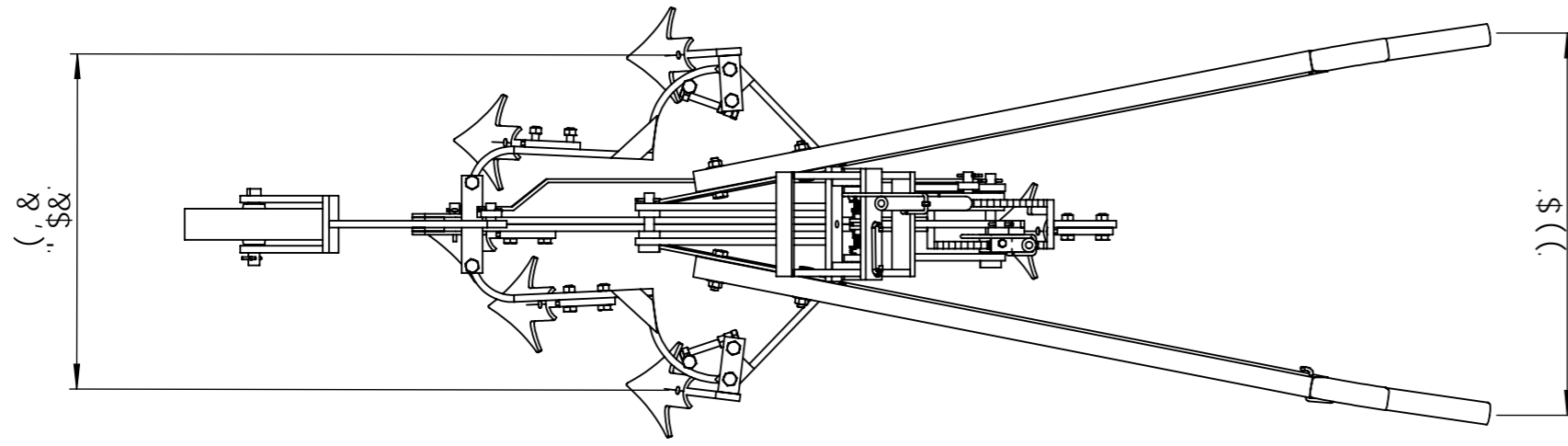

Ci h	6]bYi gY 'Bfc!D'UbYh		
8 UH	\$) #%&##&\$%*	J Yfg]cb	%"\$ dU[Y 'bš'&#'%+
D], WY	8]a Ybg]cbg		E hf %

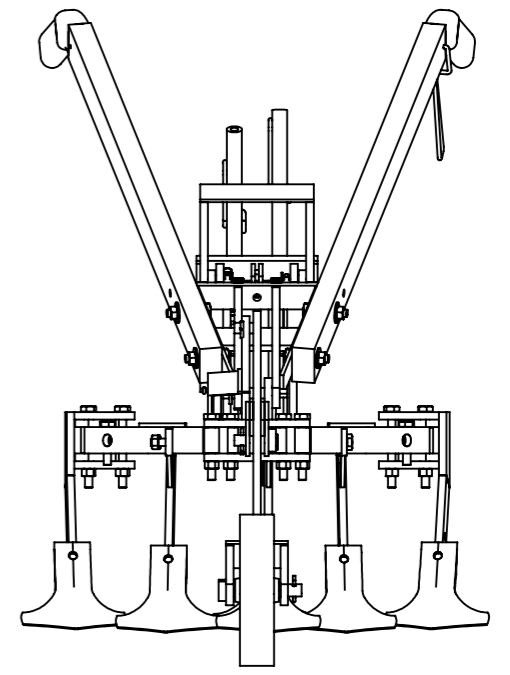
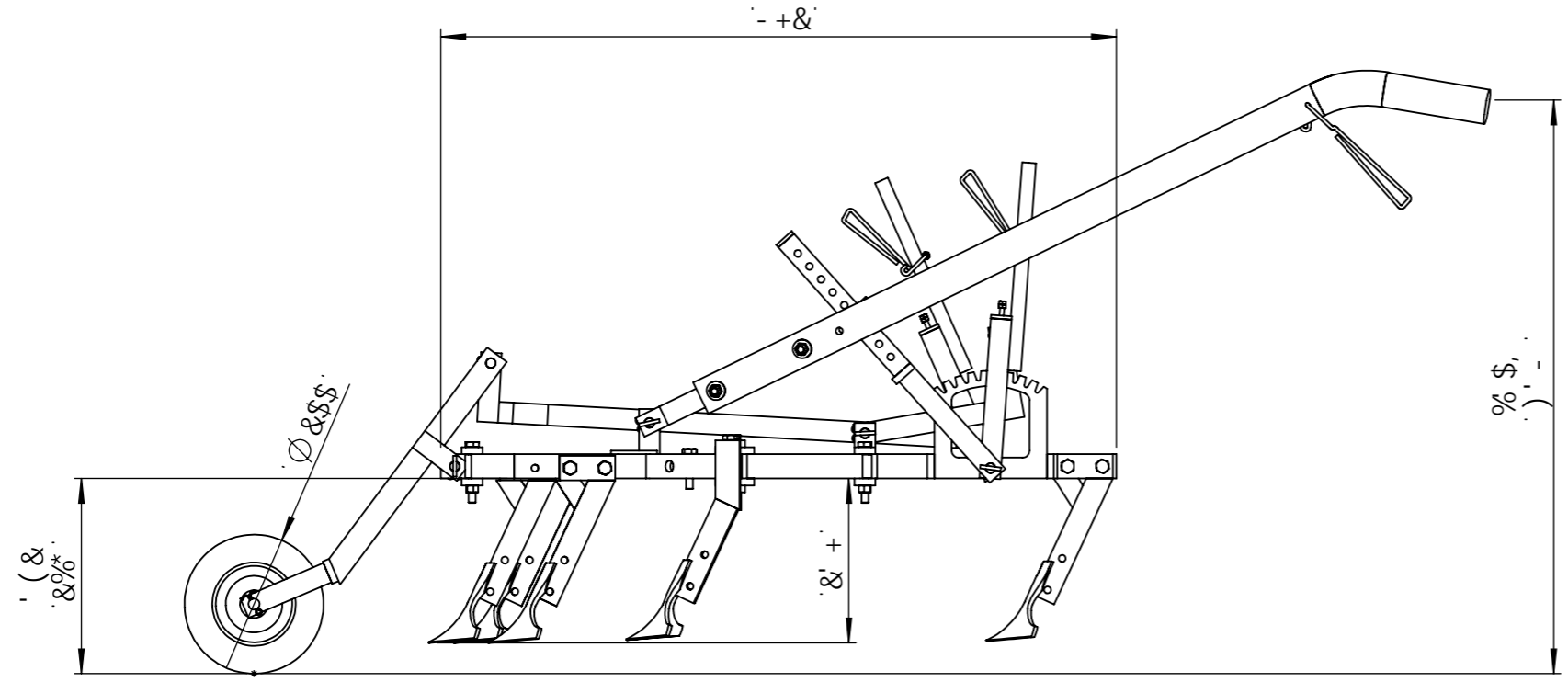

ci h	6]bYi gY 'Bfc!D'UbYh			
8 UHY	%{ #%&#&\$%*	vW\Y`Y	%%\$ dU[Y 'bš' '#%+	
D], WY	vWUhf		E hf %	

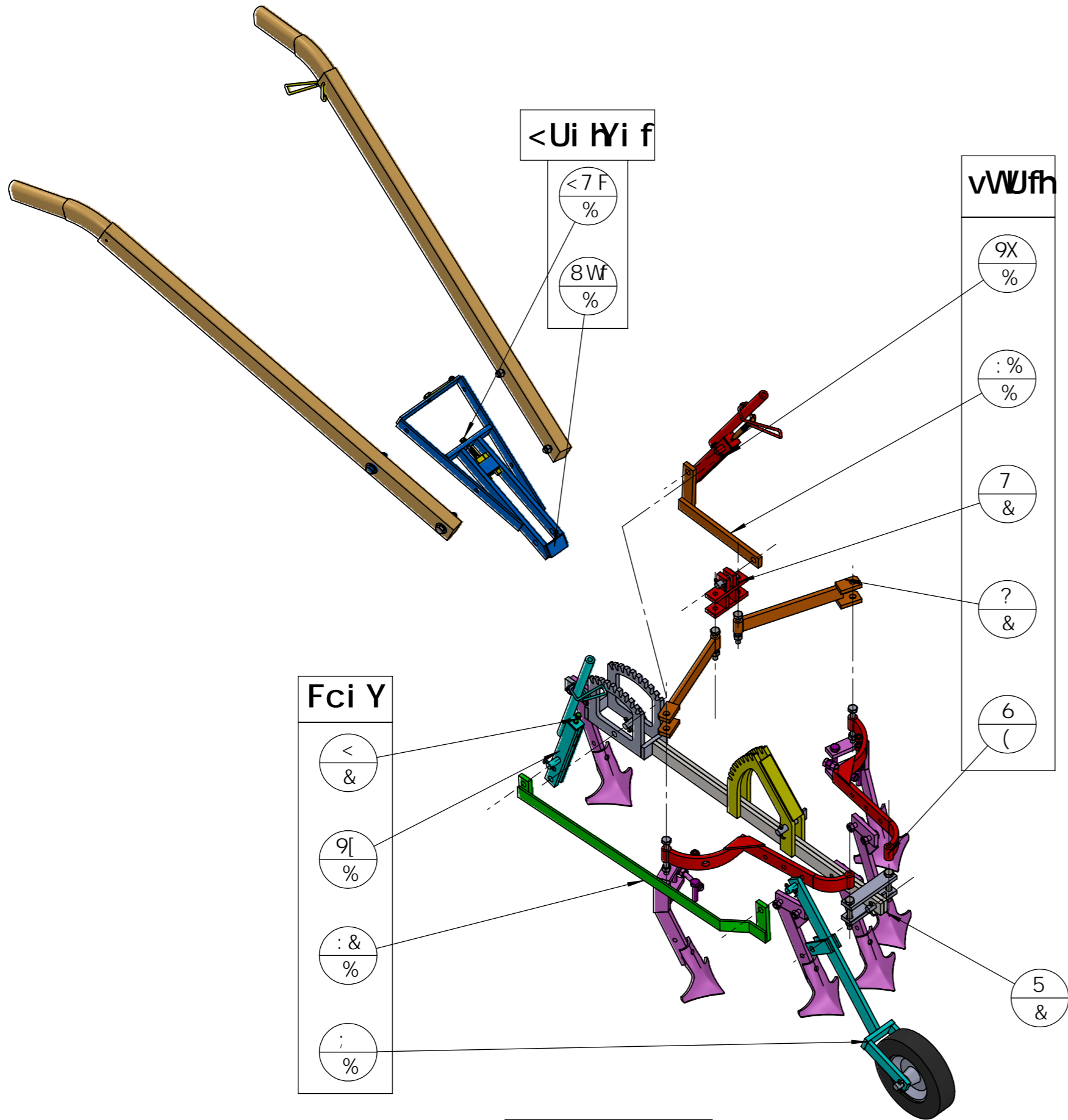

7 ffa U]` , fy

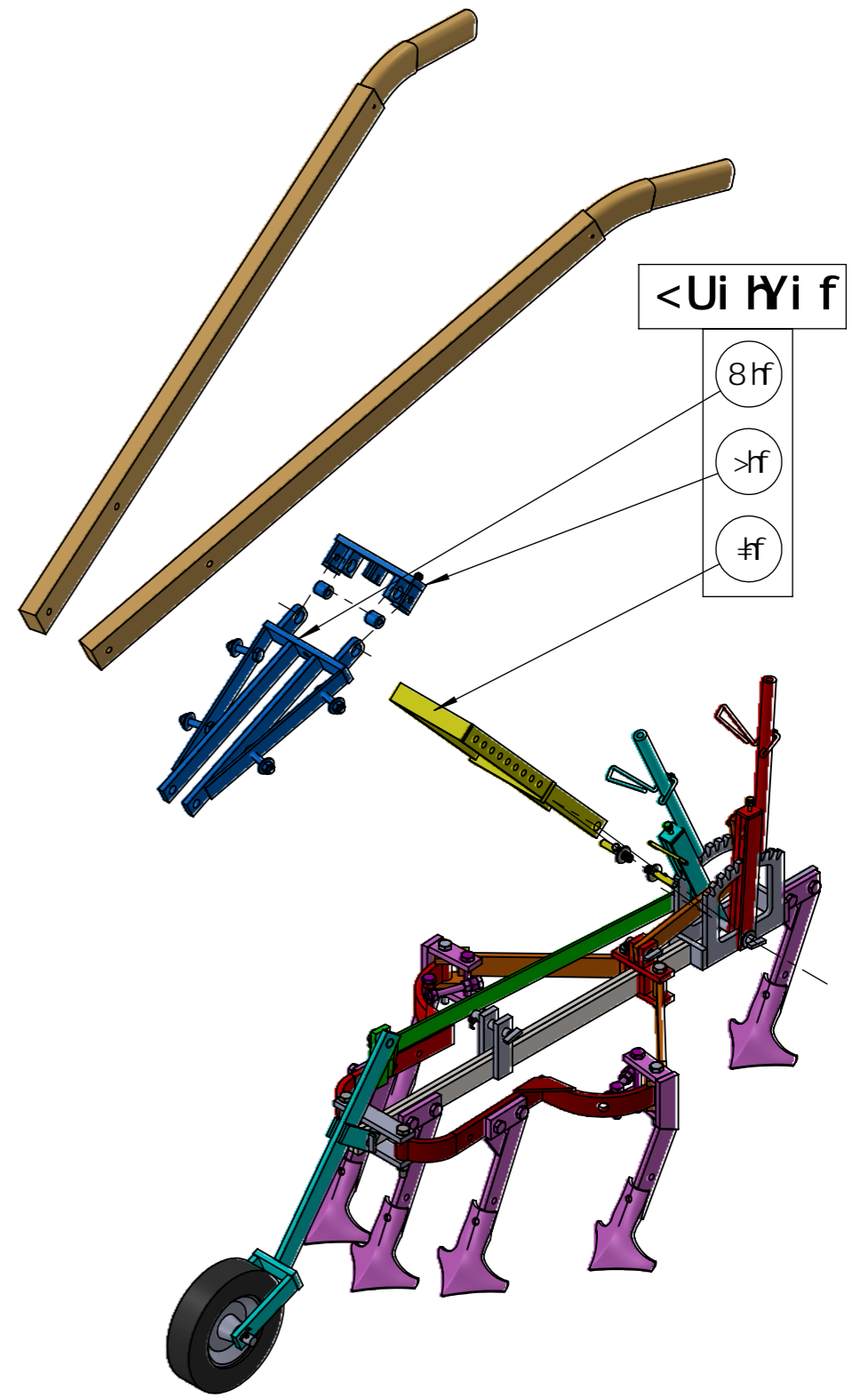

Hfci g



5%

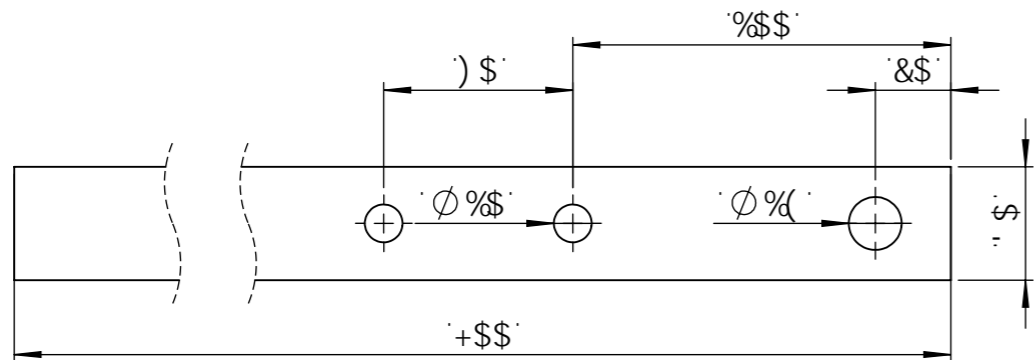

5&

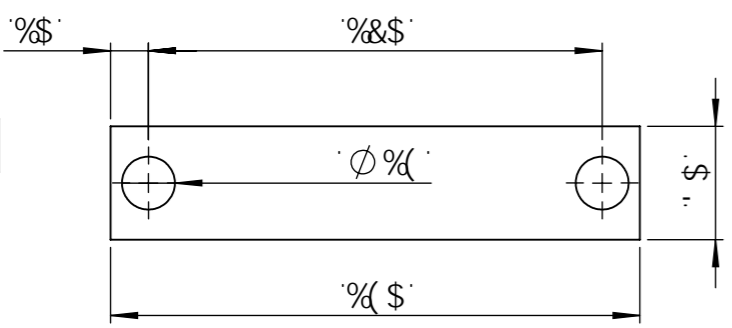

5'

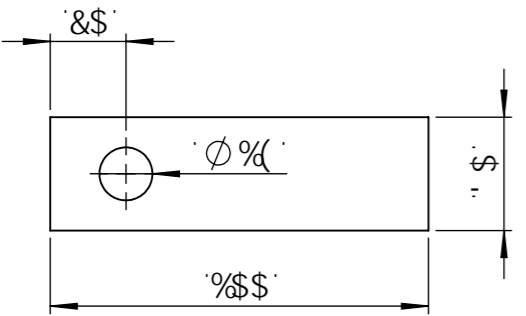

5(

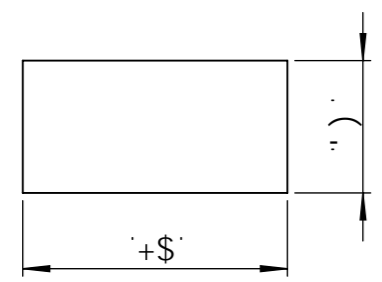

5+

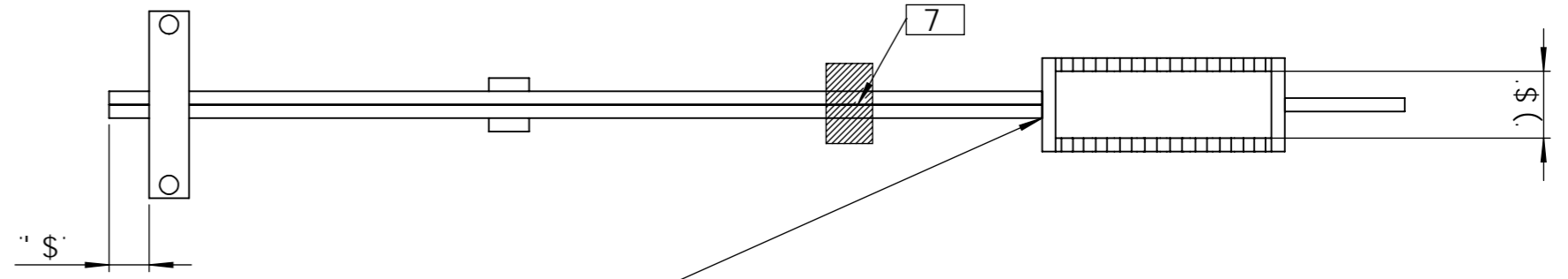
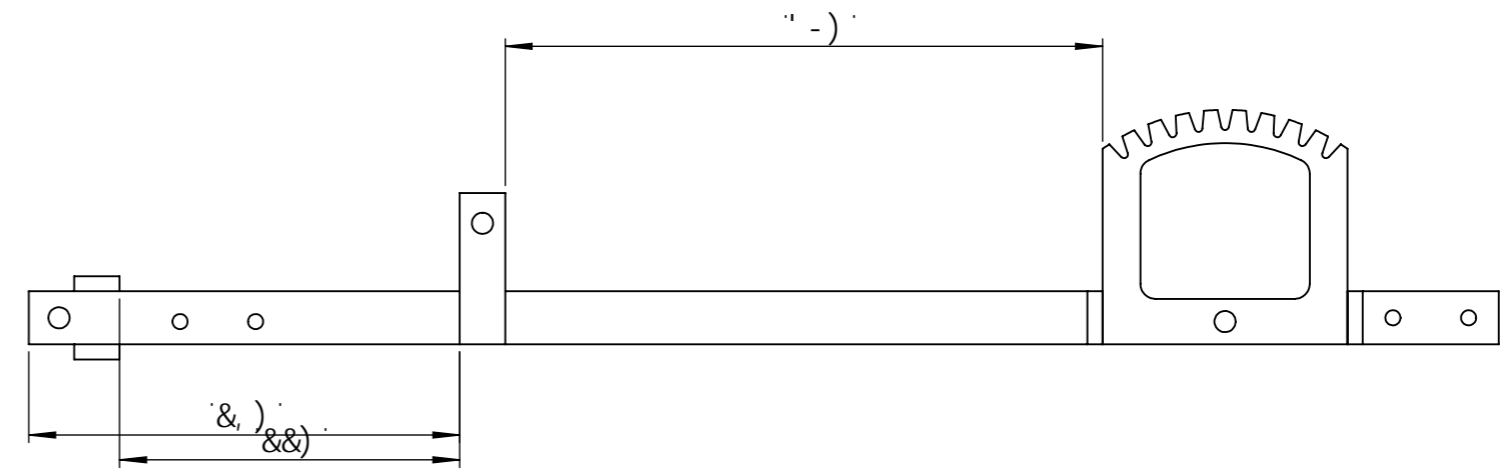
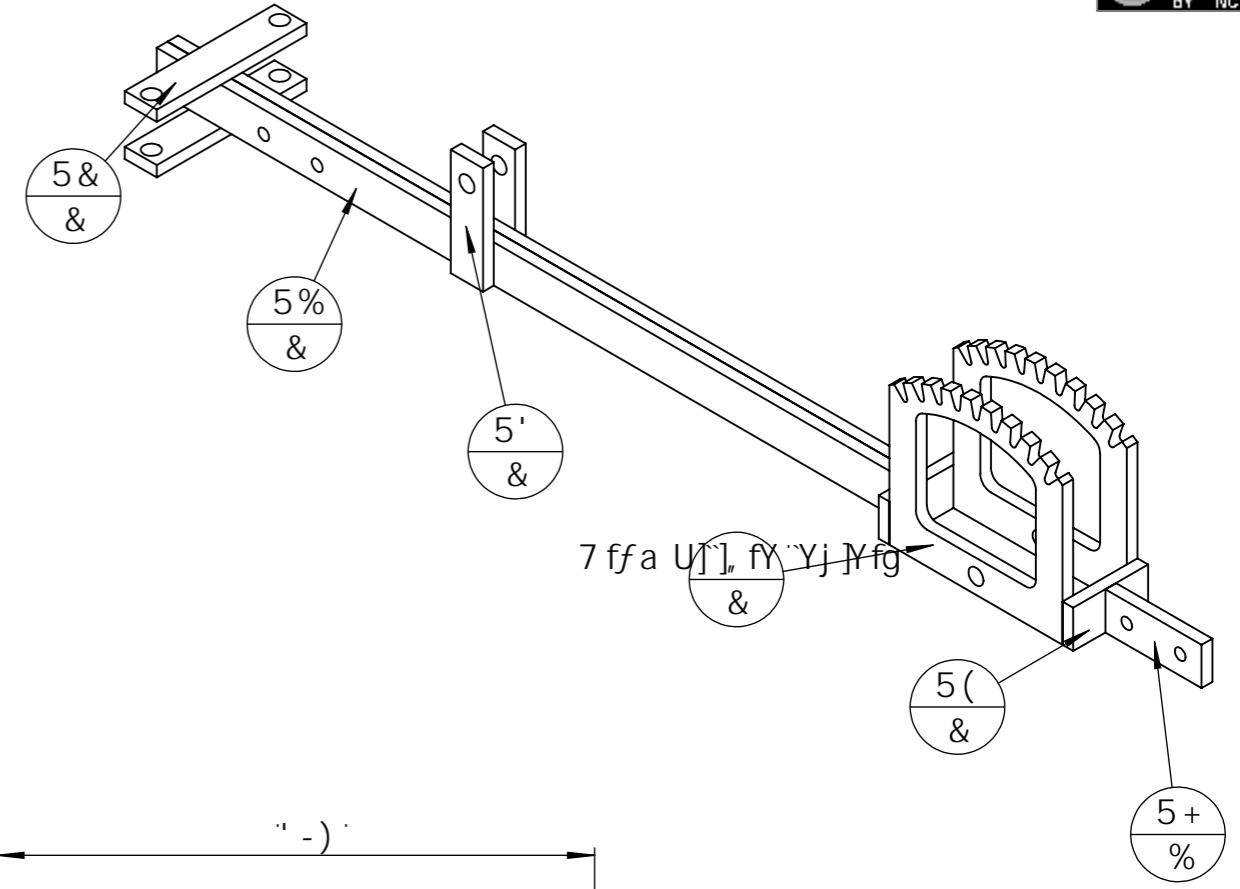
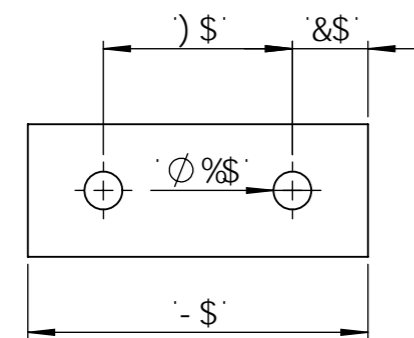

5HDBHCB : BY dUg'gci XYf'U dUfhY Uff], fY Uj UbhX flj c]fa cbhf `U[]gg], fY 7'g f5%`

Bš	8fg[bUh]cb	@b[i Yi f	E hf
5%	: Yfd'Uh') l' %\$	+\$	&
5&	f]ff' d'Uh' \$l' %\$	%(\$	&
5'	f]ff' d'Uh' \$l' %\$	%\$\$	&
5(: Yfd'Uh') l' %\$	+\$	&
5+	: Yfd'Uh') l' %\$	-\$	%
7 ffa U]], fY `Yj]Yfg	7 ffa U]], fY `Yj]Yfg		&



5%

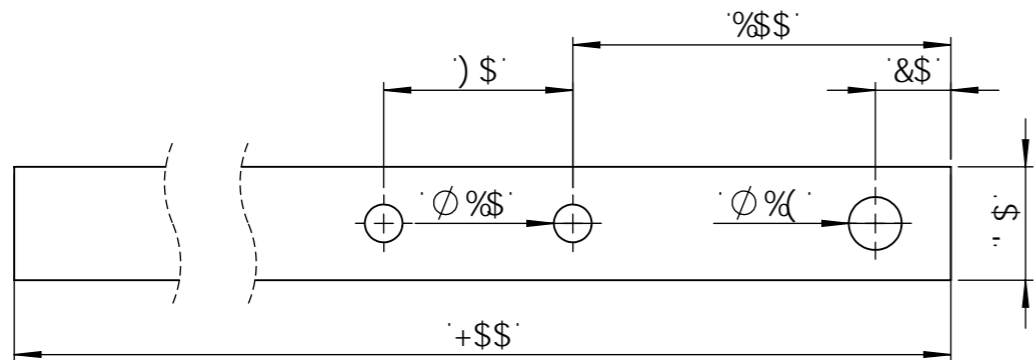

5&

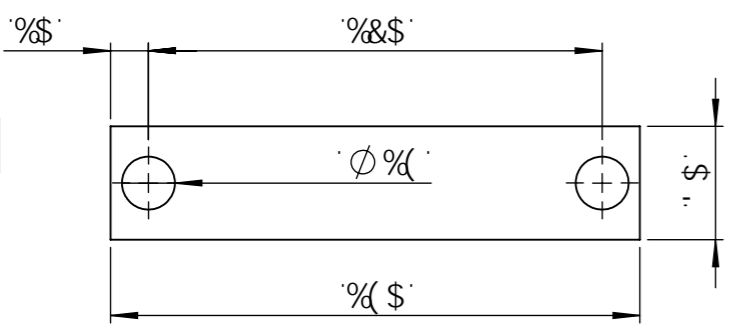

5(

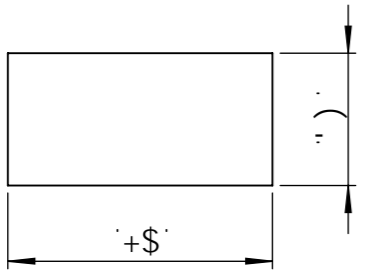

5+

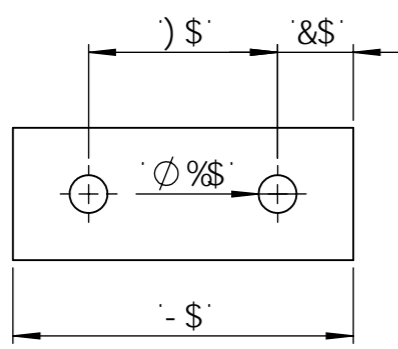

5,

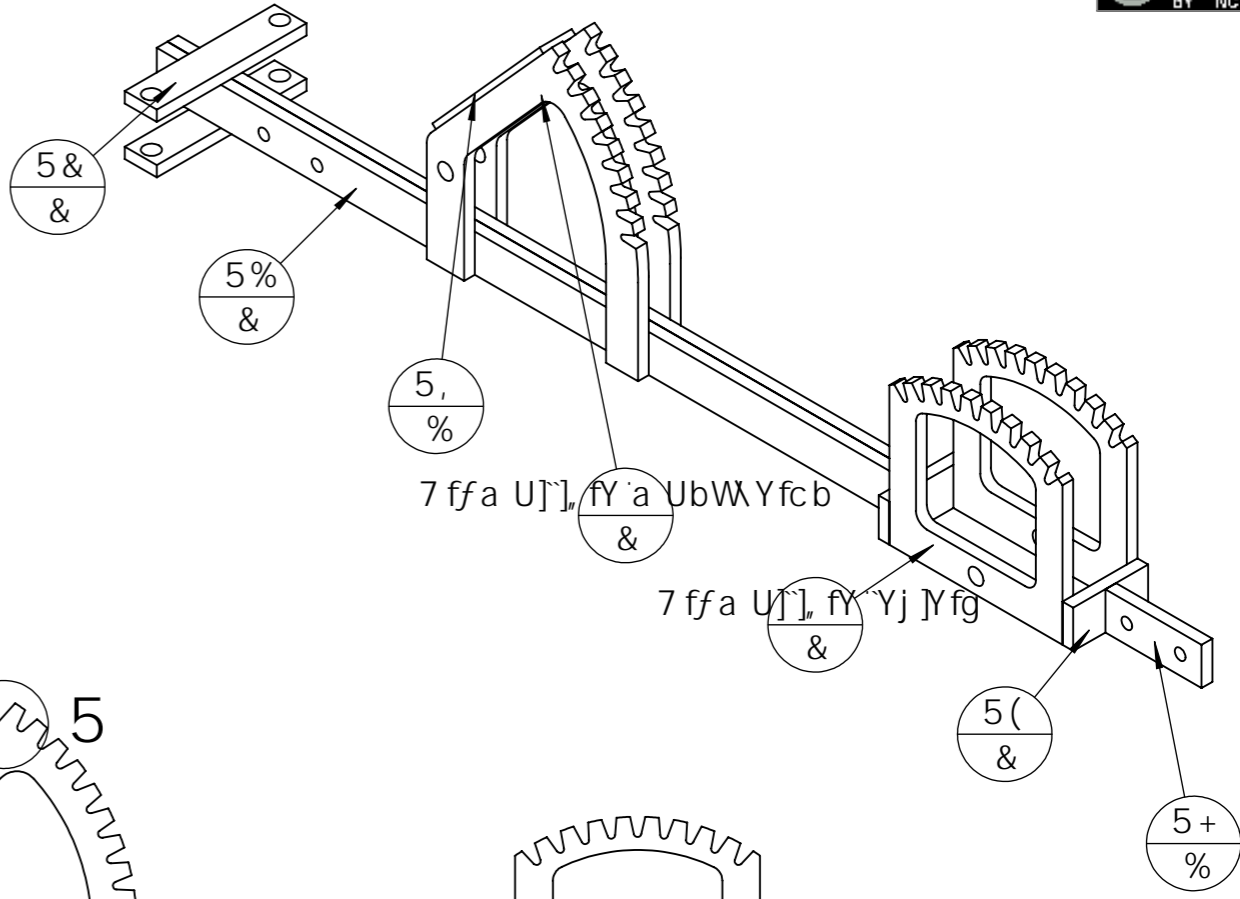
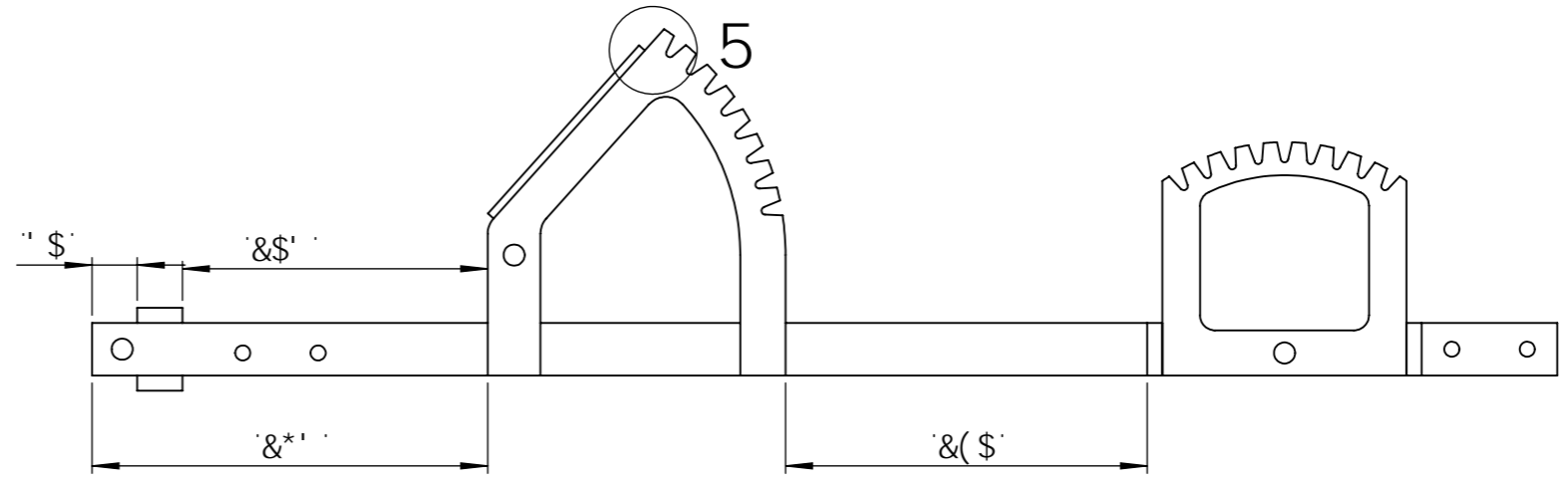
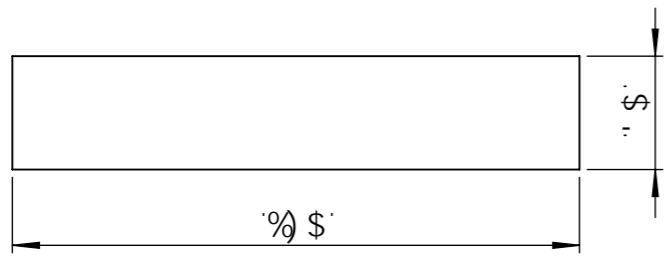

;) gYfhi b]ei Ya YbhXY fYbZc fh'
 5 hY bh]cbz' c fgXi 'dc]bhU[Yz{ '
 WY'ei fji bY XfdUggY dUg'Y '
 ZcbX XY 'XYbhXY 'U Wfa U]], fY

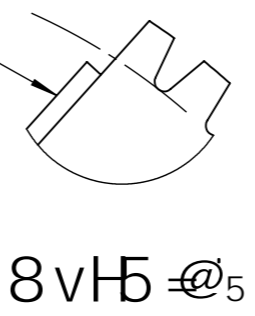

5HØBHC B : BY 'dUggci XYf'U 'dUfhY 'Uff], fY '
 Uj UbhXfuj c]fa cbhf 'U[]gg], fY '7 'g f5%'

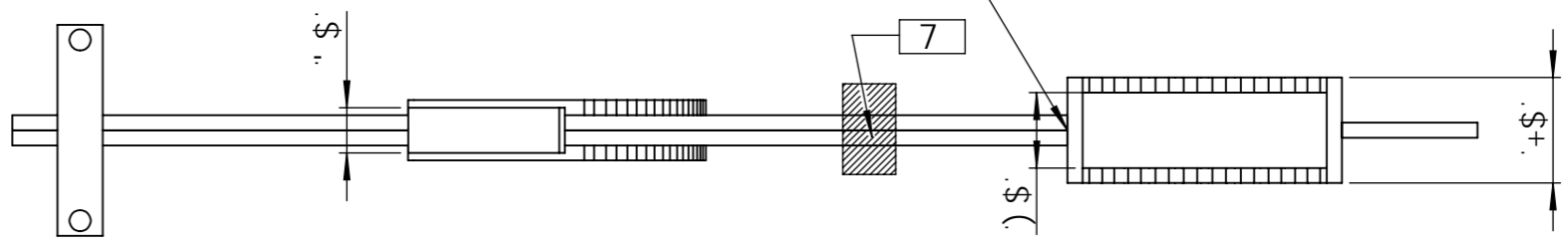

Bš	8fg[bU]cb	@b[i Yi f	E hf
5%	: Yfd 'Uh') l '%\$	+\$	&
5&	f h]f 'd 'Uh' \$ l '%\$	%(\$	&
5'	f h]f 'd 'Uh' \$ l '%\$	%\$\$	&
5(: Yfd 'Uh') l '%\$	+\$	&
5+	: Yfd 'Uh') l '%\$	-\$	%
7 ffa U]], fY 'Yj]Yfg	7 ffa U]], fY 'Yj]Yfg		&

Ci h	6]bYi gY 'Bfc! D'Ubyh		
8 UHY	% (#%&#&\$%*	vW\Y`Y	%& dU[Y 'bš' * # %+
D], WY	6	E hf	%



5Hybhcb: 68 Yh6; X]Z, fybhdUf'U'gra fhfY
Xi W]bhU[Y: YgdYf, U[YgXY 6X# %
Xc] Ybh..hfY j Yfg Y VUgZ Yh6' j Yfg Y \Ui h

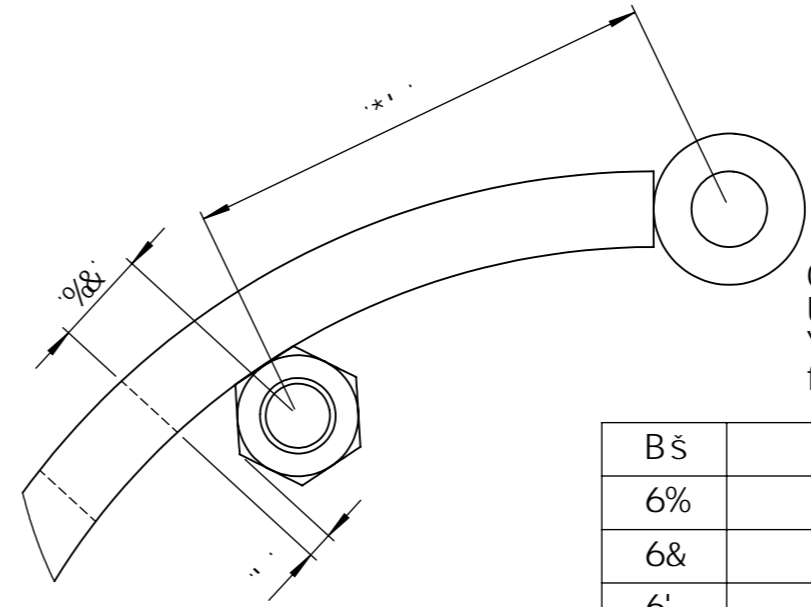
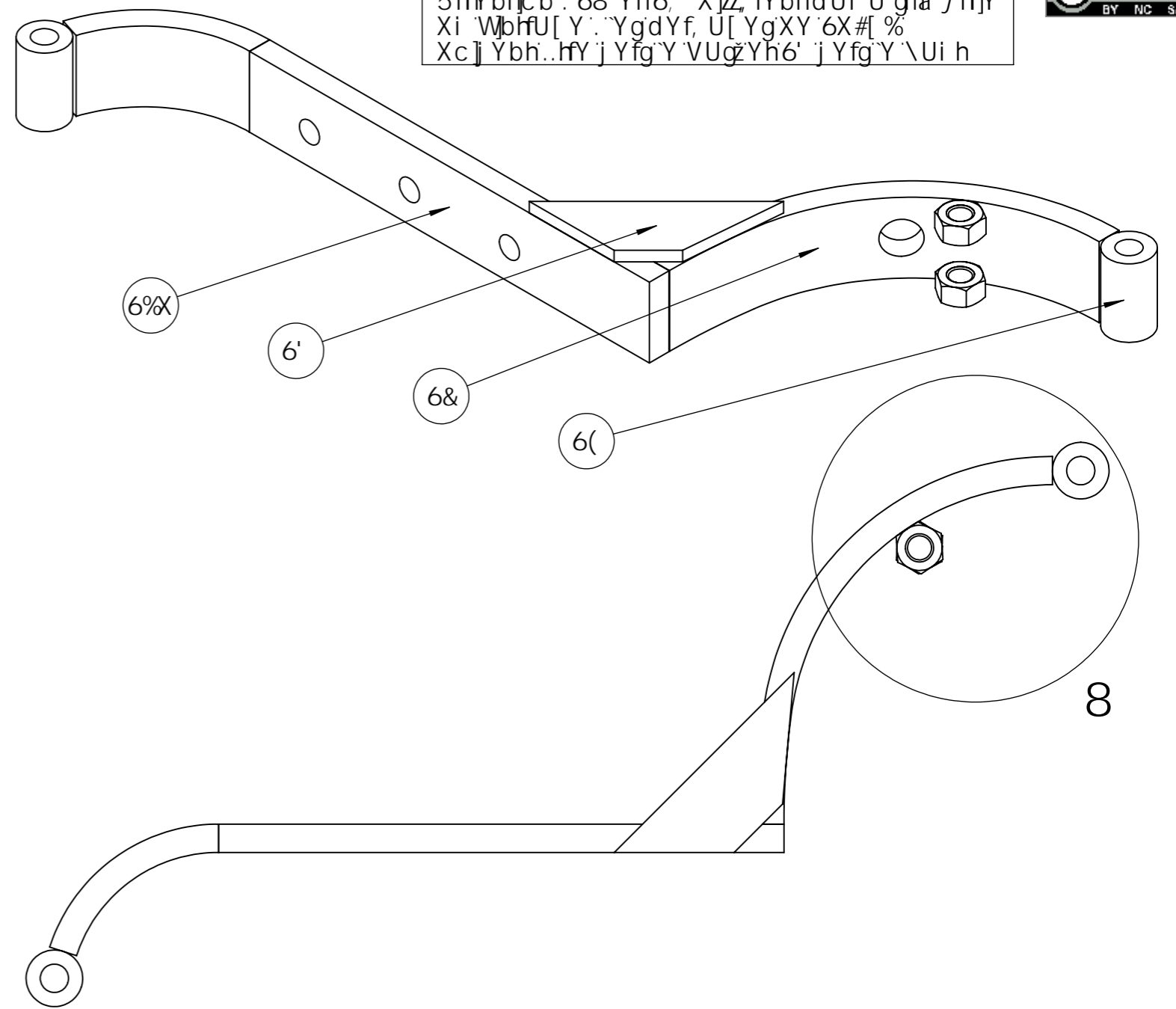
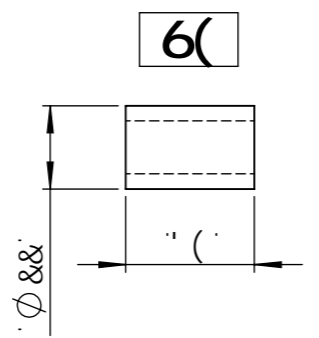
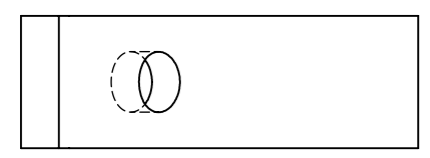
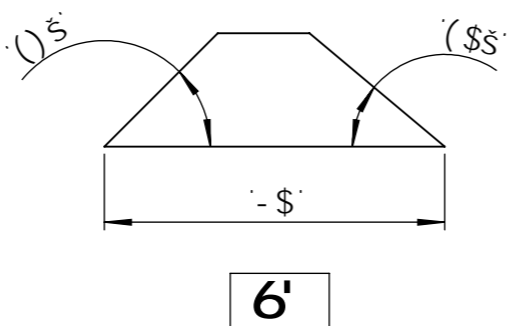
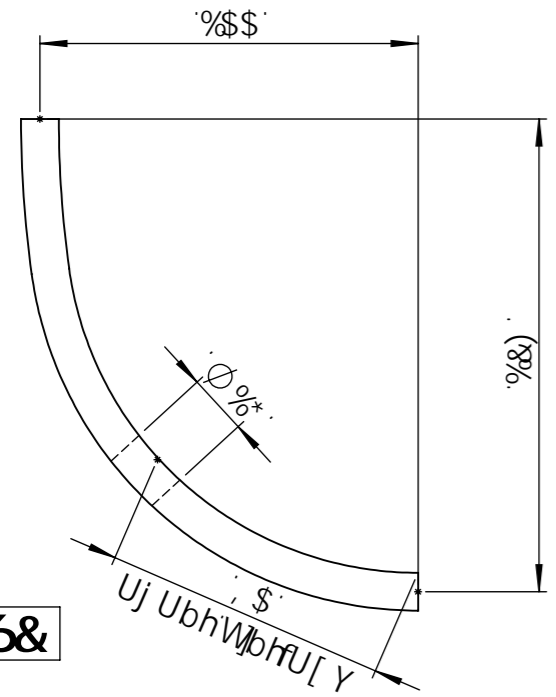
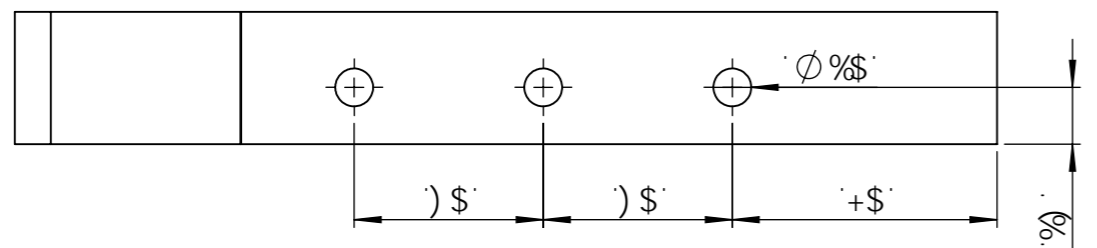
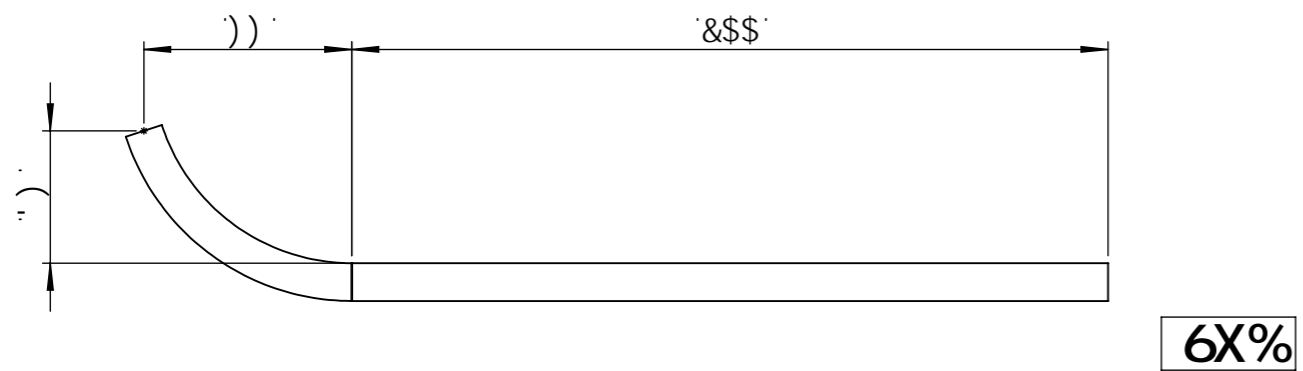

8vH5 @8
97 < 9@@ % . %

Gci XYf Ygf Wfci ga cbhf gg fi b'Vci `cbž
Uj YWfci h'fUggYa VU[Y XY ff [U[Y Xi 'gc W
Yb'd UW' dci fU] [bYfUj YWY dYf, U[Y « %*
f] c] f d % L

Bš	8fg] [bUh]cb	@b[i Yi f	E hf
6%	: Yfd'Uh') l' %\$	&+&ž+\$	%
6&	: Yfd'Uh') l' %\$	&- %ž% %	%
6'	: Yfd'Uh' \$l)	- \$	%
6(fVUi W\Y 'h' Vi 'U]fY '&&l' (' \$	%
6)	fVUi W\Y 'h' Vi 'U]fY '&&l' (')	%

Ci h̄	6]bYi gY 'Bfc!D'UbYh		
8 UH̄	\$) #%&#&\$%*	J Y fg]c b	%"\$ dU[Y 'bš'+ '#%+
D], W̄	7 '! :	E hf	%

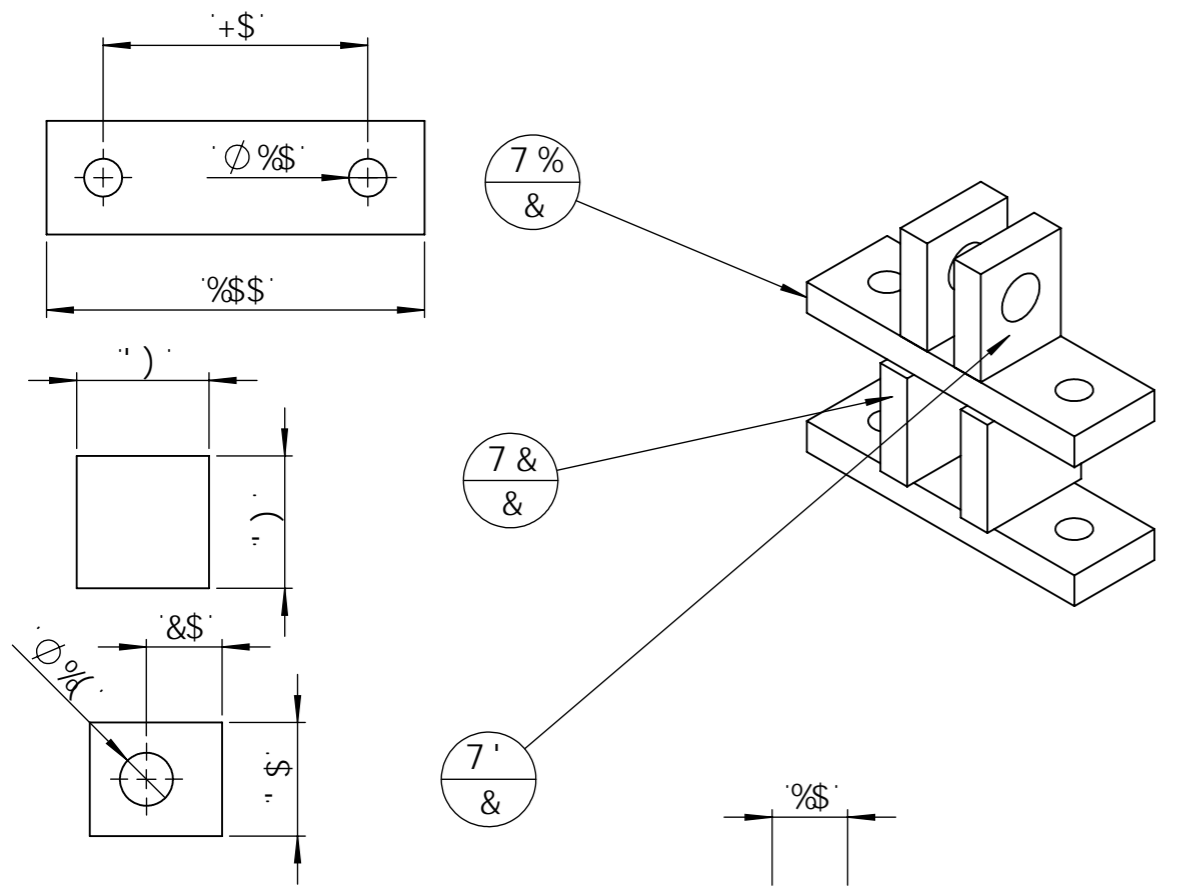

7 YhYgdUW' Wc bgh̄i Y 'U []gg, fY
 Ybh̄fY 7 Yh5"BY dUg'gci XYfh̄cd
 gYffždci fei Y, U'di]ggY Wci]ggY f'

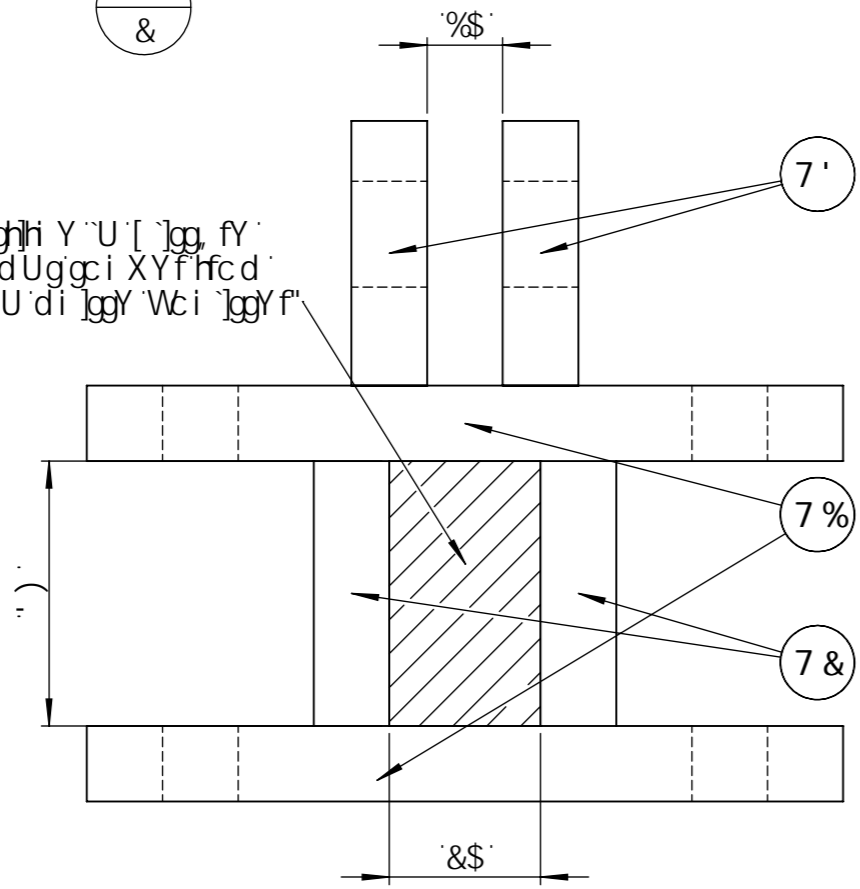

Bš	8 fg] bUh]c b	@b[i Yi f	E hf
7 %	f h̄ff 'd 'Uh' \$'l '%\$	%\$\$	&
7 &	: Yf'd 'Uh')'l '%\$	')	&
7 '	f h̄ff 'd 'Uh' \$'l '%\$	')	&

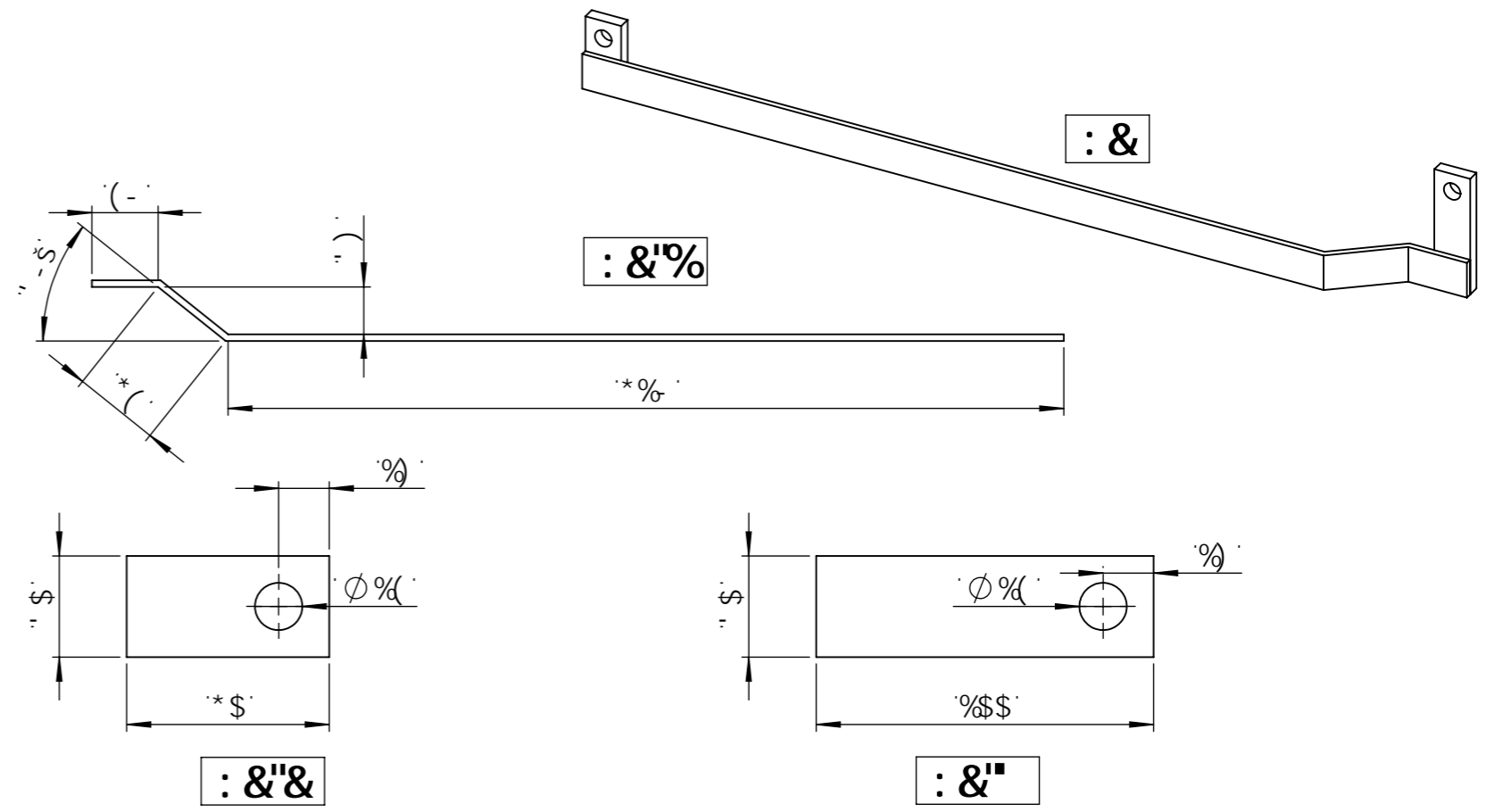
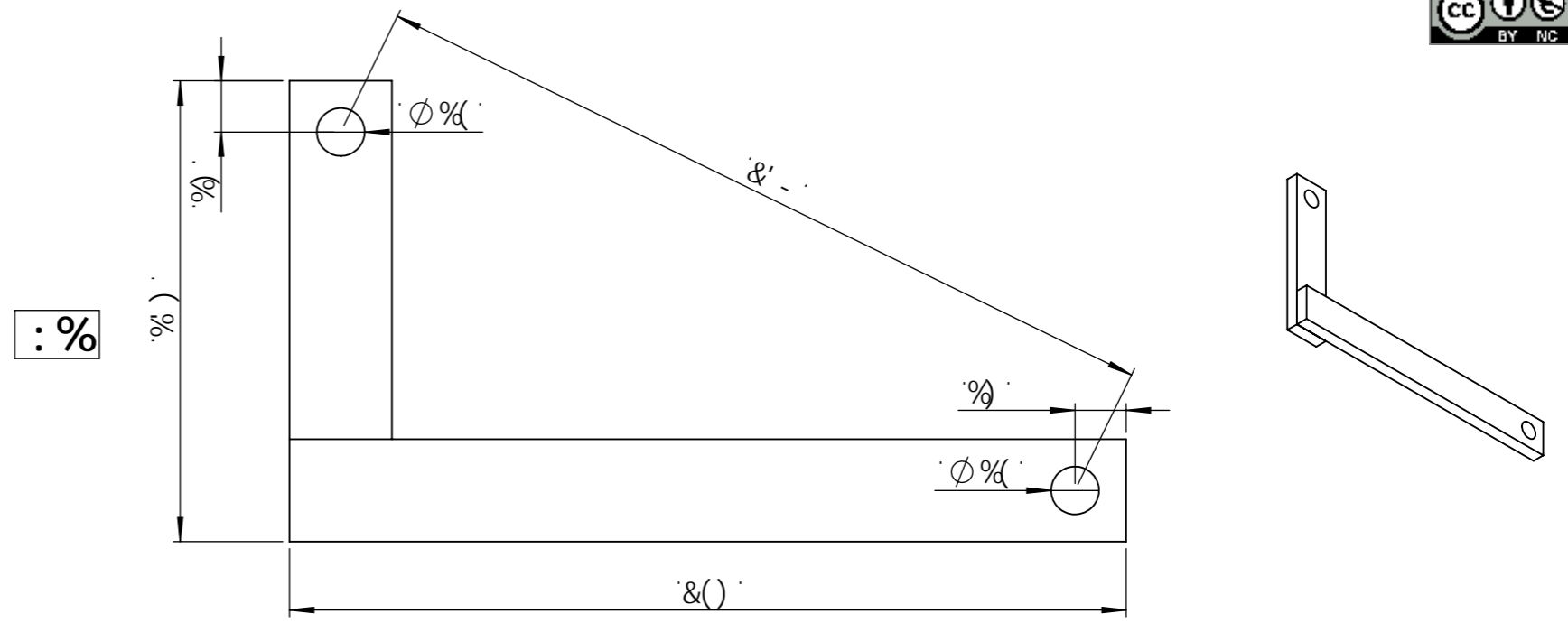

Bš	8 fg] bUh]c b	@b[i Yi f	E hf
: %"	f h̄ff 'd 'Uh' \$'l '%\$	&()	%
: %&	f h̄ff 'd 'Uh' \$'l '%\$	%')	%
: &'%	: Yf'd 'Uh' \$'l ')	+&\$	%
: &'&	f h̄ff 'd 'Uh' \$'l '%\$	*\$	%
: &'"	f h̄ff 'd 'Uh' \$'l '%\$	%\$\$	%

Ci h̄ 6]bYi gY 'Bfc! D'UbYh
 8UH ̄(#%&#&\$%* vWY`Y %& dU[Y' bš, '#%+
 D], W 8W E hf %



8W%

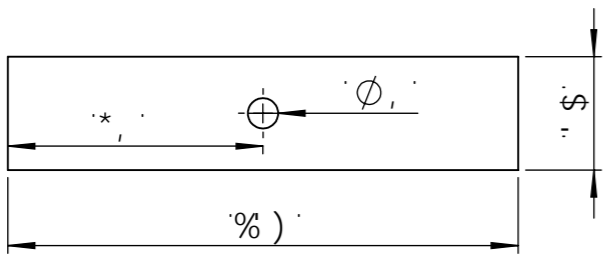

8W&

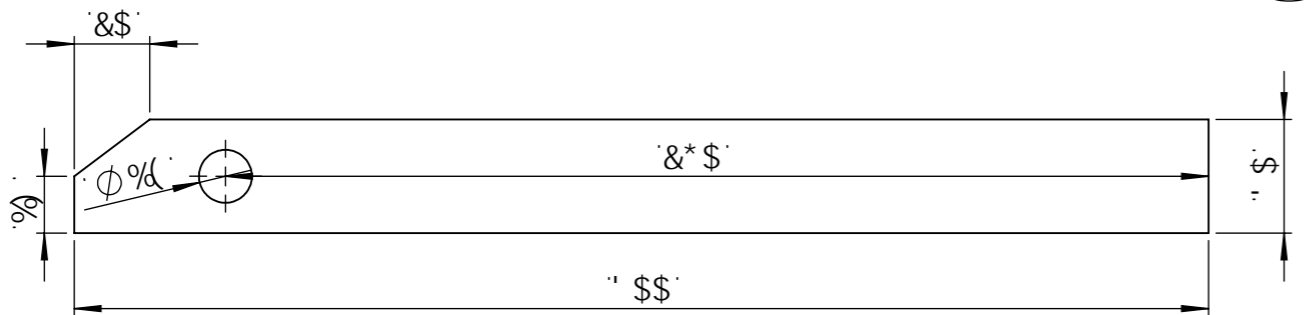

8W

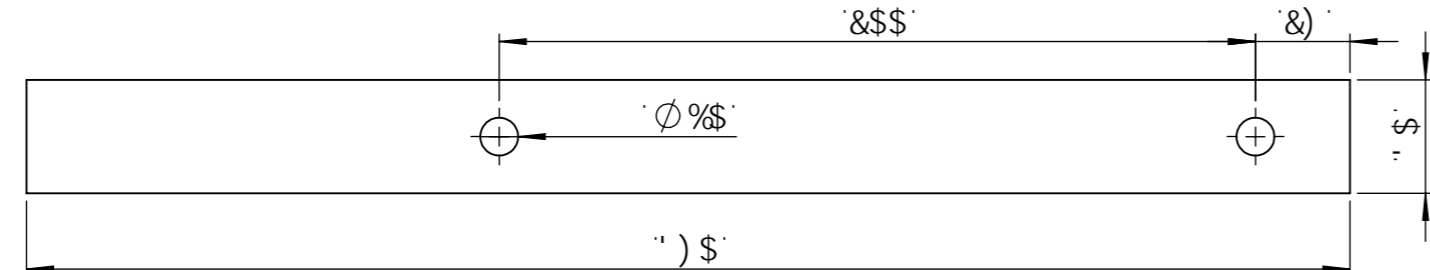

8W)

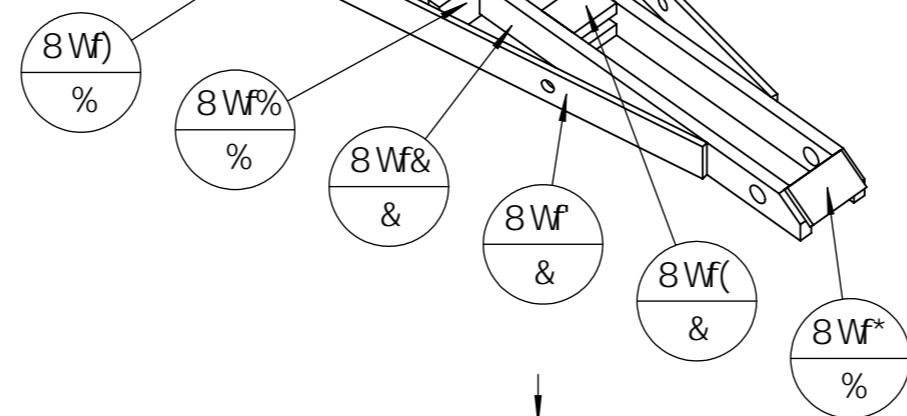
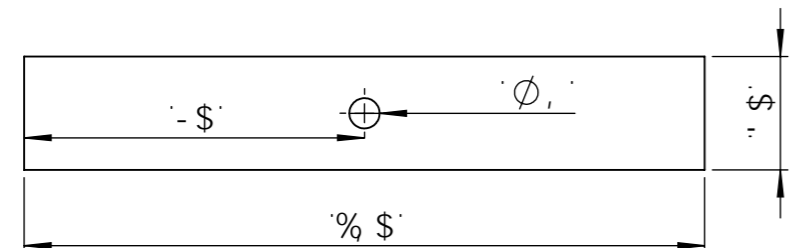

8W(

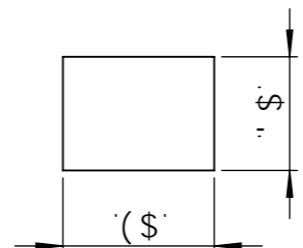

8W*

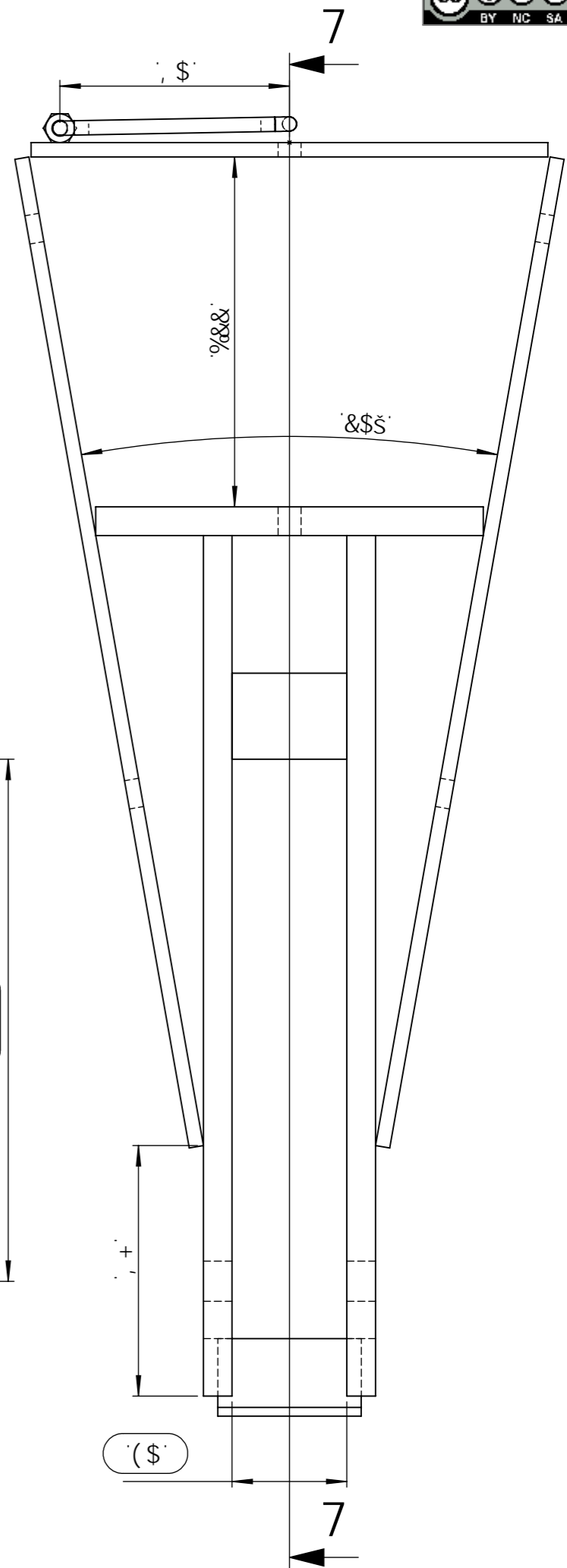
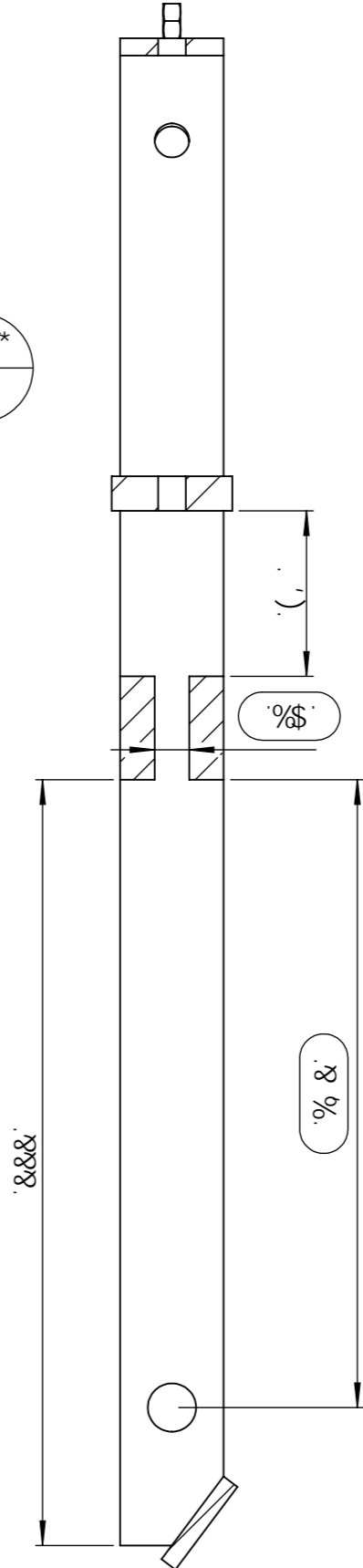
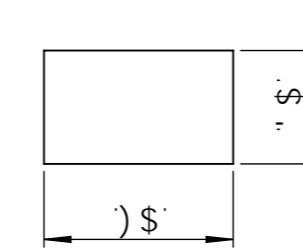

Bš	8fgl[bUh]cb	@b[i Yi f	E hf
8W%	: Yfd'Uh') i %\$	%)	%
8W&	f]f' d'Uh' \$I %\$	' \$\$	&
8W'	: Yfd'Uh' \$I)	') \$	&
8W(f]f' d'Uh' \$I %\$	(\$	&
8W)	: Yfd'Uh' \$I)	% \$	%
8W*	: Yfd'Uh' \$I)) \$	%
9Wci	9Wci 'A * Vfi h		%
8W+	f]f' fcbX'«)	%(\$	%
8W,	f]f' fcbX'«)	(')	%

Ci h	6]bYi gY 'Bfc! D'Ubyh		
8 UH	% (# % & # & \$ % *)	vW\Y`Y	% & dU[Y 'bš' - # % +
D], W	8hf	E hf	%



8hf%

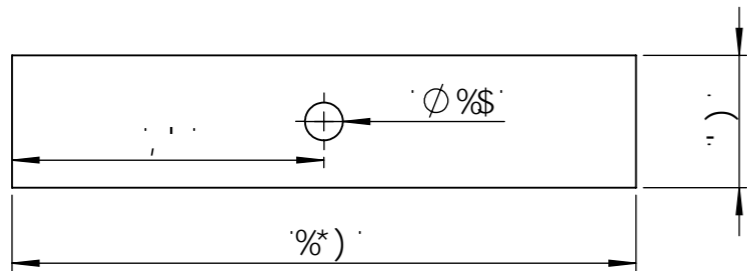

8hf&

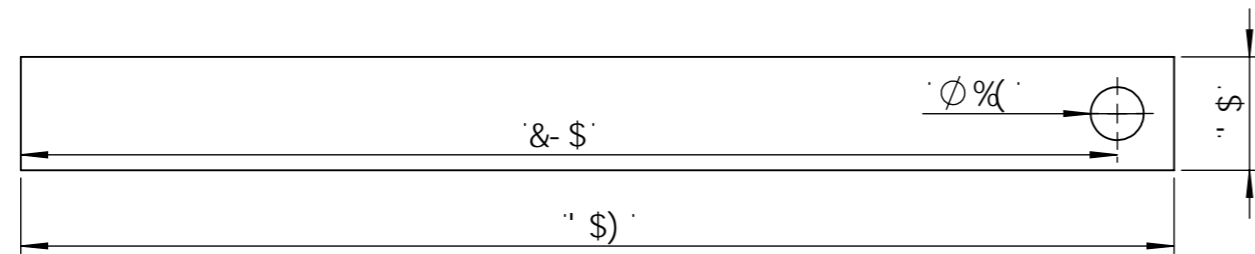

8hf

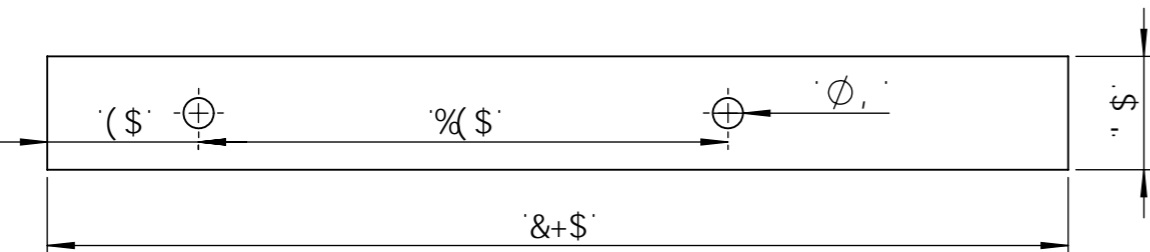

8hf(

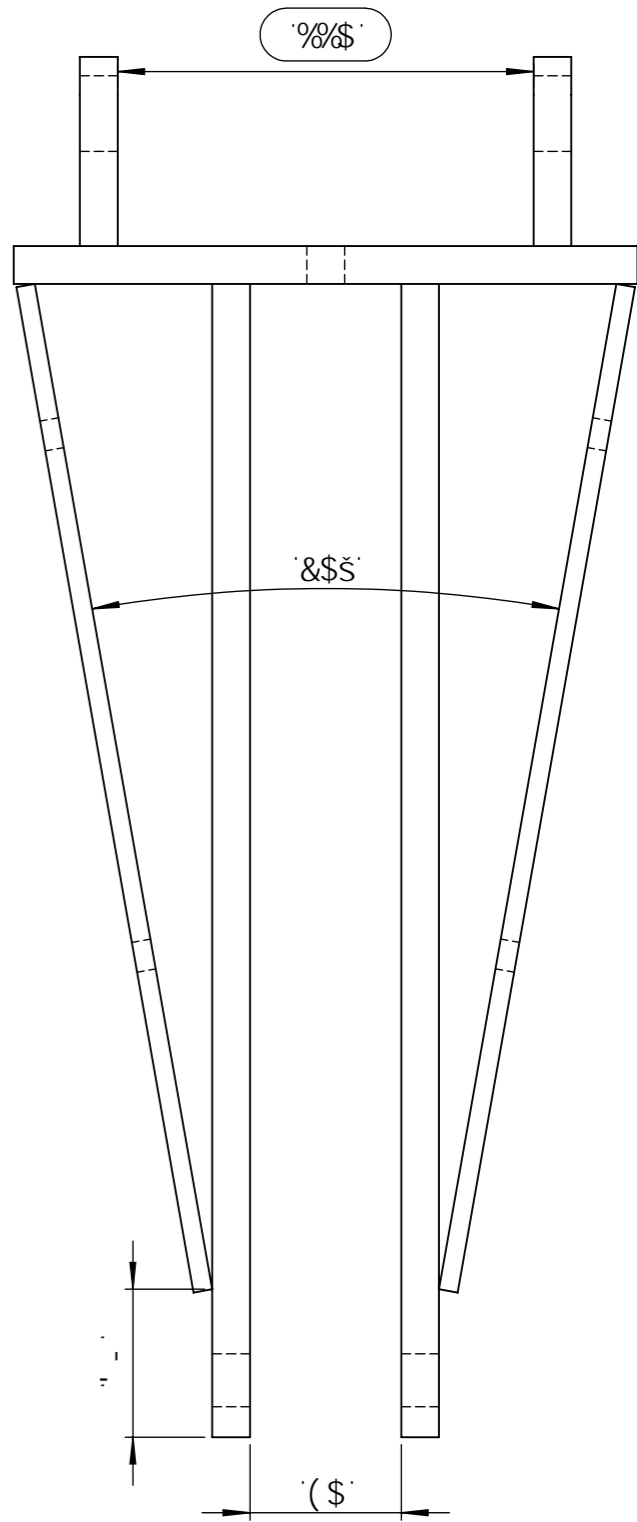
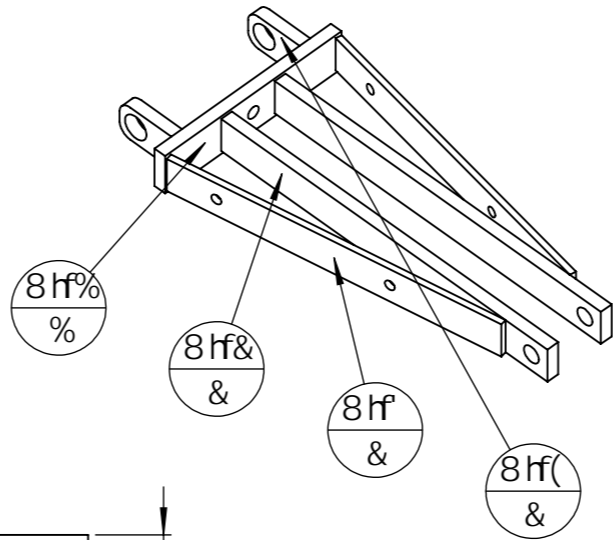
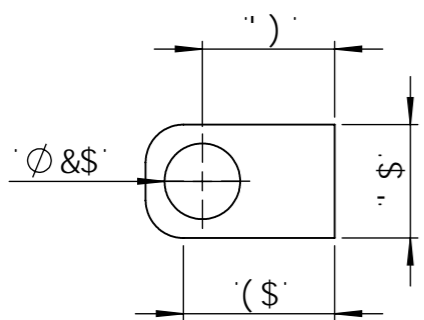

Bš	8fgl[bUhcb	@b[i Yi f	E hf
8hf%	: Yfd'Uh') l' % \$	% *)	%
8hf&	f h f f ' d ' Uh' \$ l' % \$	' \$)	&
8hf	: Yfd'Uh' \$ l')	& + \$	&
8hf(f h f f ' d ' Uh' \$ l' % \$) \$	&

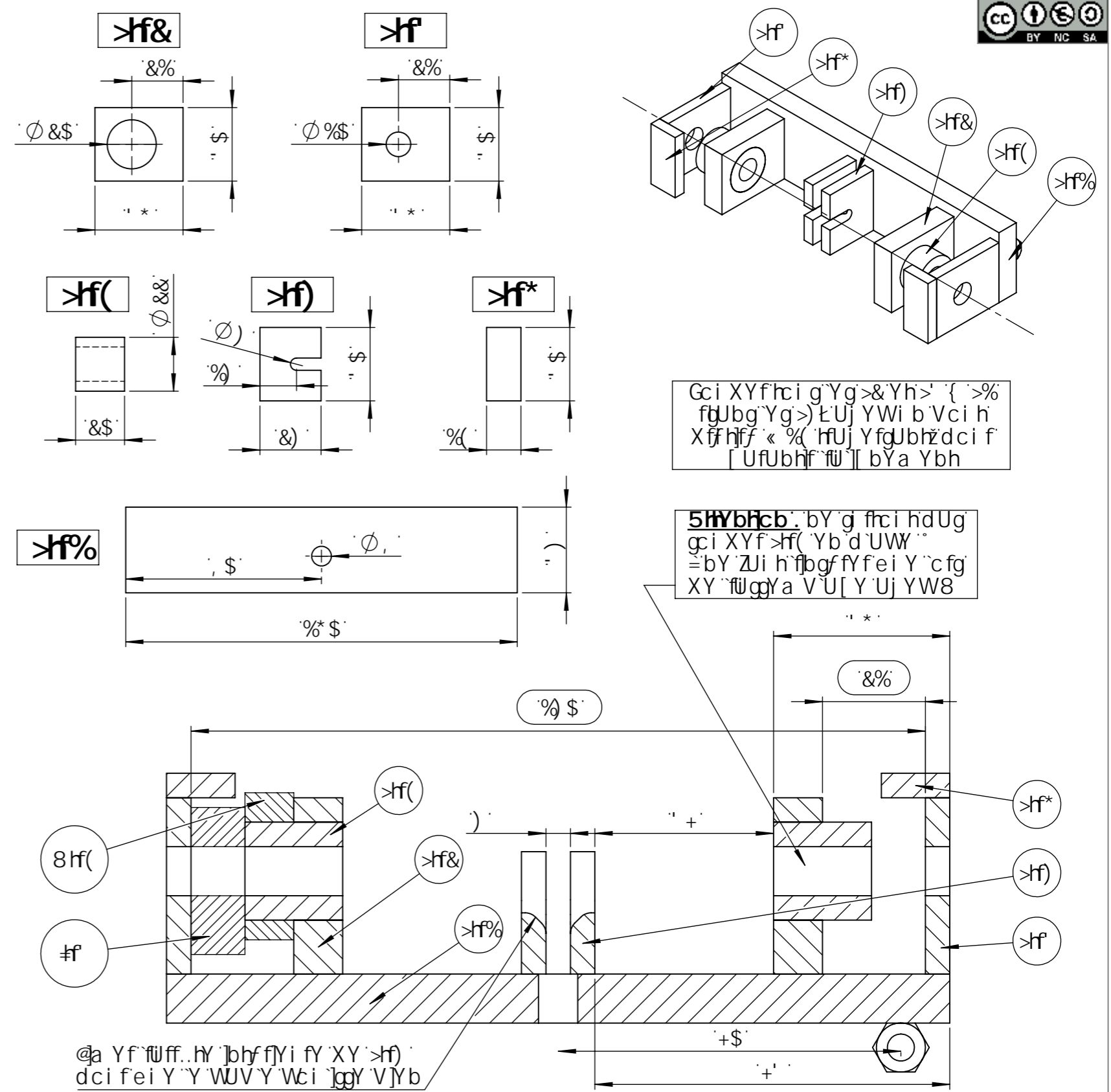
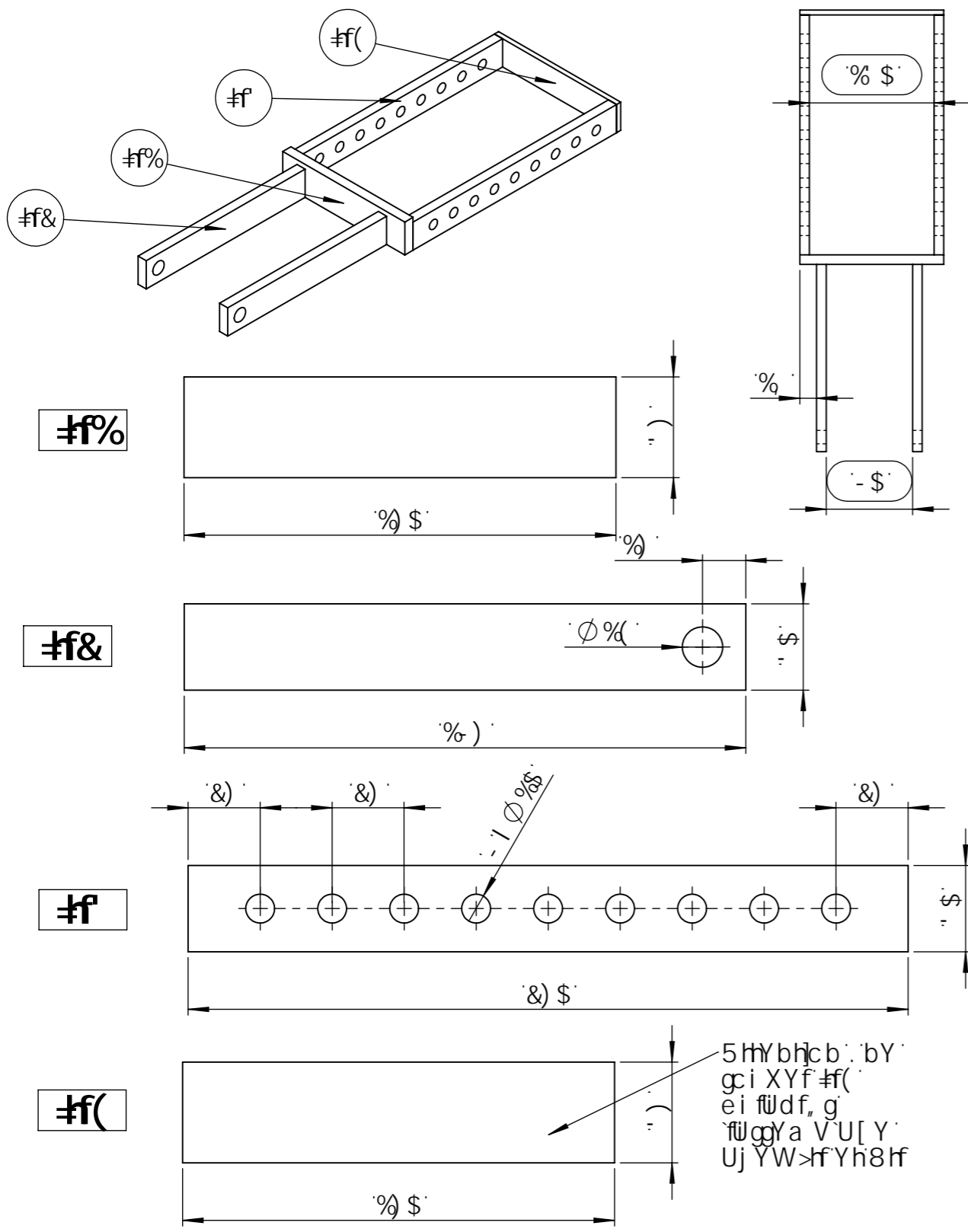

Gci XYf hci g'Yg>&Yh> { >%
 fUbg'Yg>) t'Uj YWi b'Vci h
 Xf hf < % (hfUj YfgUbjh' dci f'
 [UfUbh' fU] bYa Ybh

5hYbhcb: bY' g' fci hdUg
 gci XYf>hf('Yb'd'UW' "
 =bY' ZUj h'fbgf'fyfei Y'c'fg
 XY' fUggYa V'U[Y'Uj YW8

@a Yf' fUff.. hY']bh' fYi fY' XY' >hf'
 dci fei Y' Y' WUV' Y' Wci']ggY' V'Yb

Bš	8fgl[bUhc b	@b[i Yi f	E hf
#f%	: Yfd'Uh') i' %\$	%\$	%
#f&	f h'f' d'Uh' \$i' %\$	%)	&
#f	f h'f' d'Uh' \$i' %\$	&\$	&
#f(: Yfd'Uh' \$i')	%\$	%

Bš	8fgl[bUhc b	@b[i Yi f	E hf
>f%	: Yfd'Uh') i' %\$	%\$	%
>f&	f h'f' d'Uh' \$i' %\$	' *	&
>f	: Yfd'Uh' \$i')	' *	&
>f(fVUi WY' h' Vi' U]fY' &\$i')	&\$	&
>f)	: Yfd'Uh' \$i')	&)	&
>f*	: Yfd'Uh' \$i')	%	&
9Wci	9Wci 'A * Vfi h		%

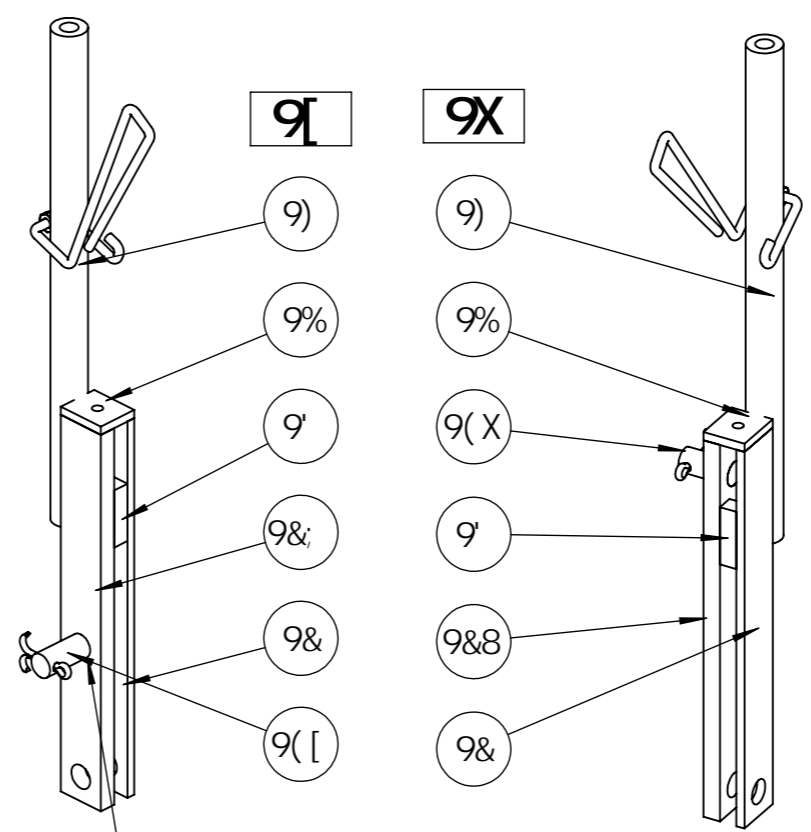
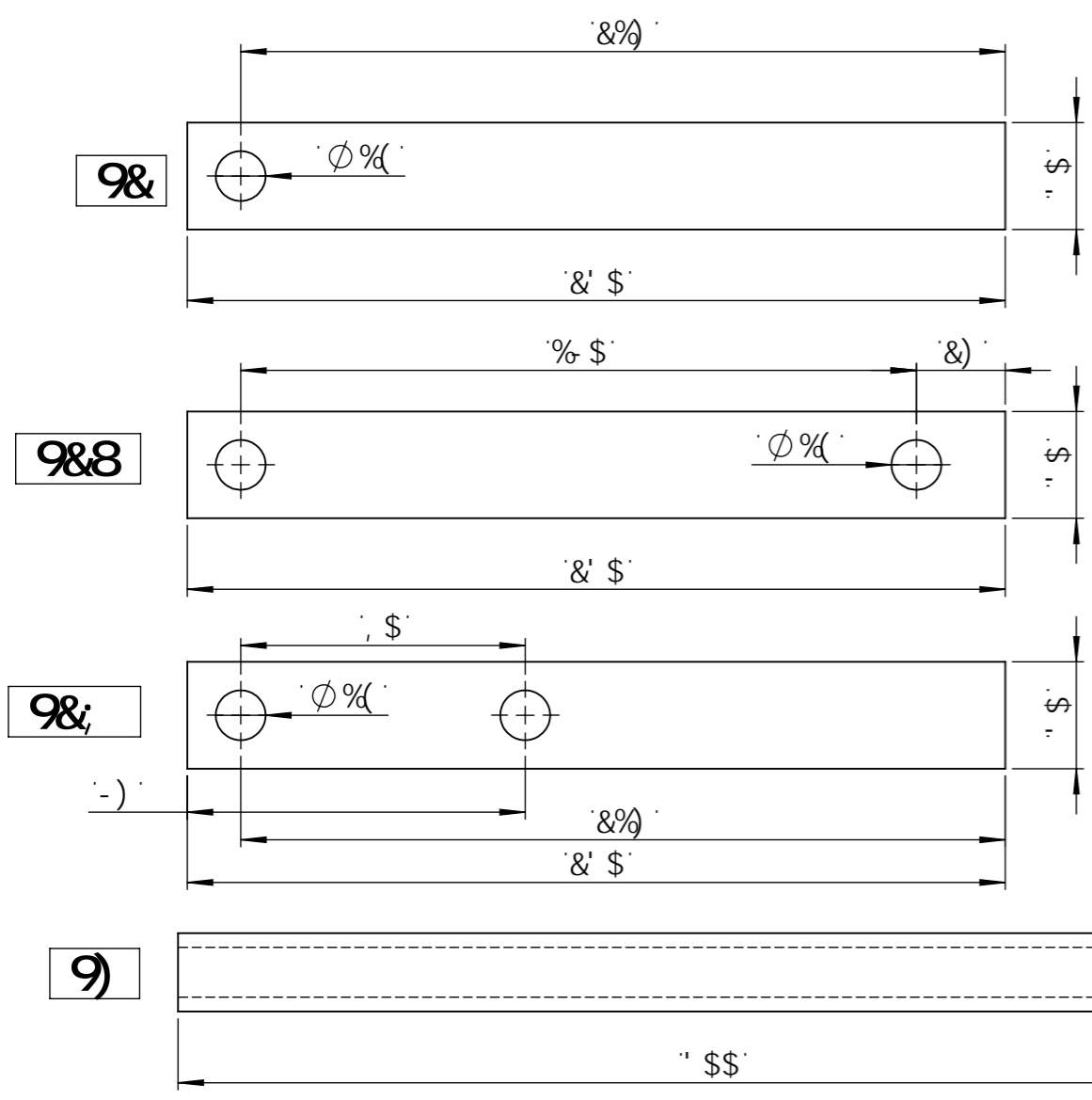

5hYbhcb: bY dUggci XYf9(g fW W hf
 XY 9&: ci 9&8" 7U Ya d..WYfUjh
 fUggYa V'U[Y Uj YW: %Yh: &"

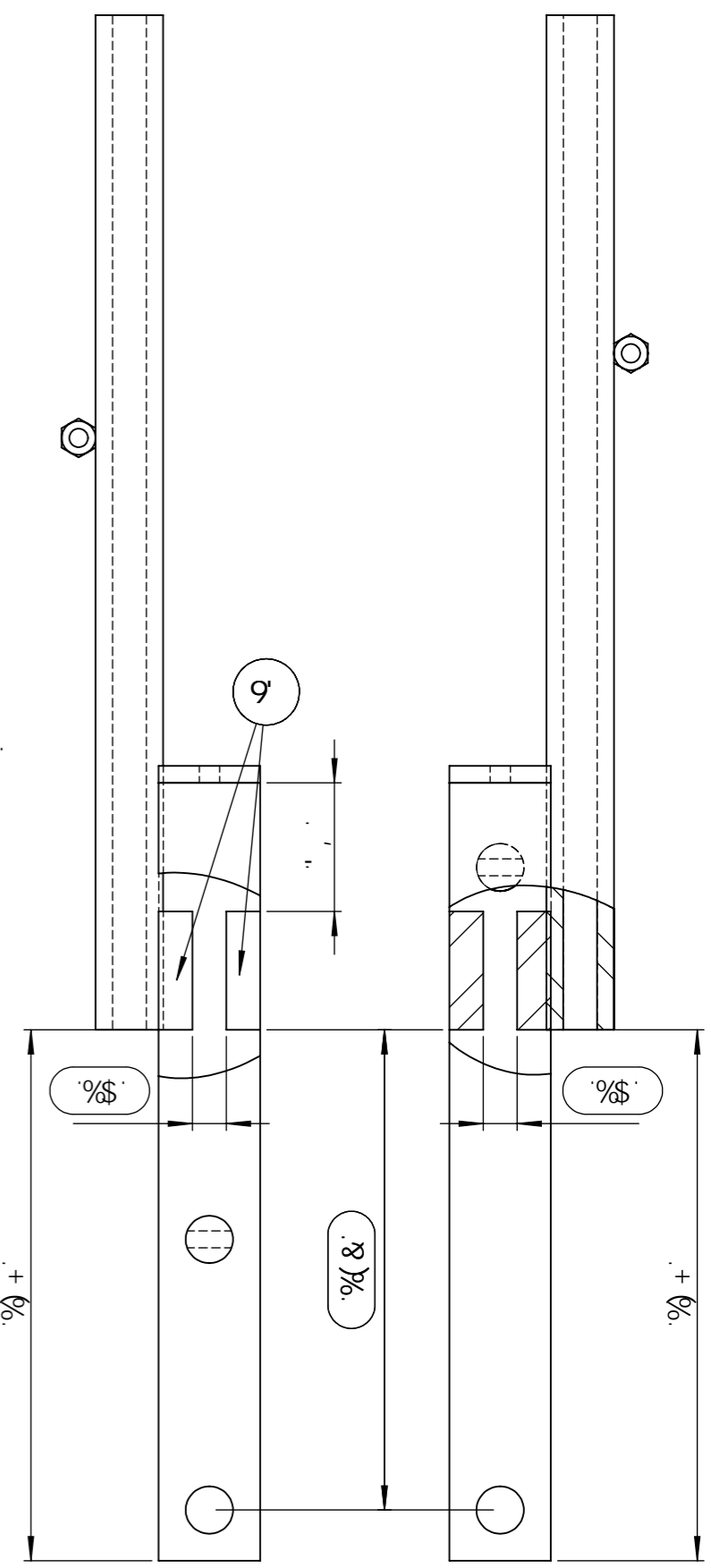

Bš	8fgl[bUhcb	@b[i Yi f	E hf
9%	: Yfd'Uh' \$i)	&)	&
9&	: Yfd'Uh' \$i)	&' \$	&
9&8	f hff d'Uh' \$i %\$	&' \$	%
9&:	f hff d'Uh') i %\$	&+ \$	%
9'	: Yfd'Uh') i %\$	%\$	(
9(X	f hff fcbX « %	' \$	&
9)	h VY fcbX &\$i)	' \$\$	&
; ci d]Y ZYbXi Y	; ci d]Y ZYbXi Y) i ' \$		&
9*	f hff fcbX «)	'))	%
9Wfci	9Wfci 'A * Vfi h		%

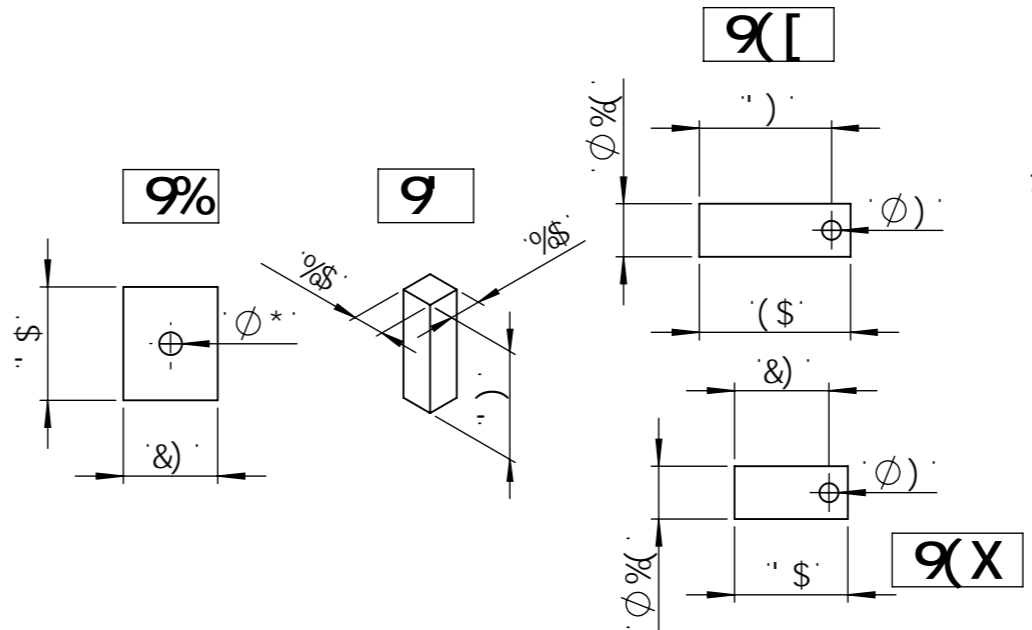

ci h 6]bYi gY 'Bfc! D'Ubyh

8 UHY % (# % & # \$ % * v W \ Y ` Y % & d U [Y ' b s ` % & # % +

D] WY ; E hf %

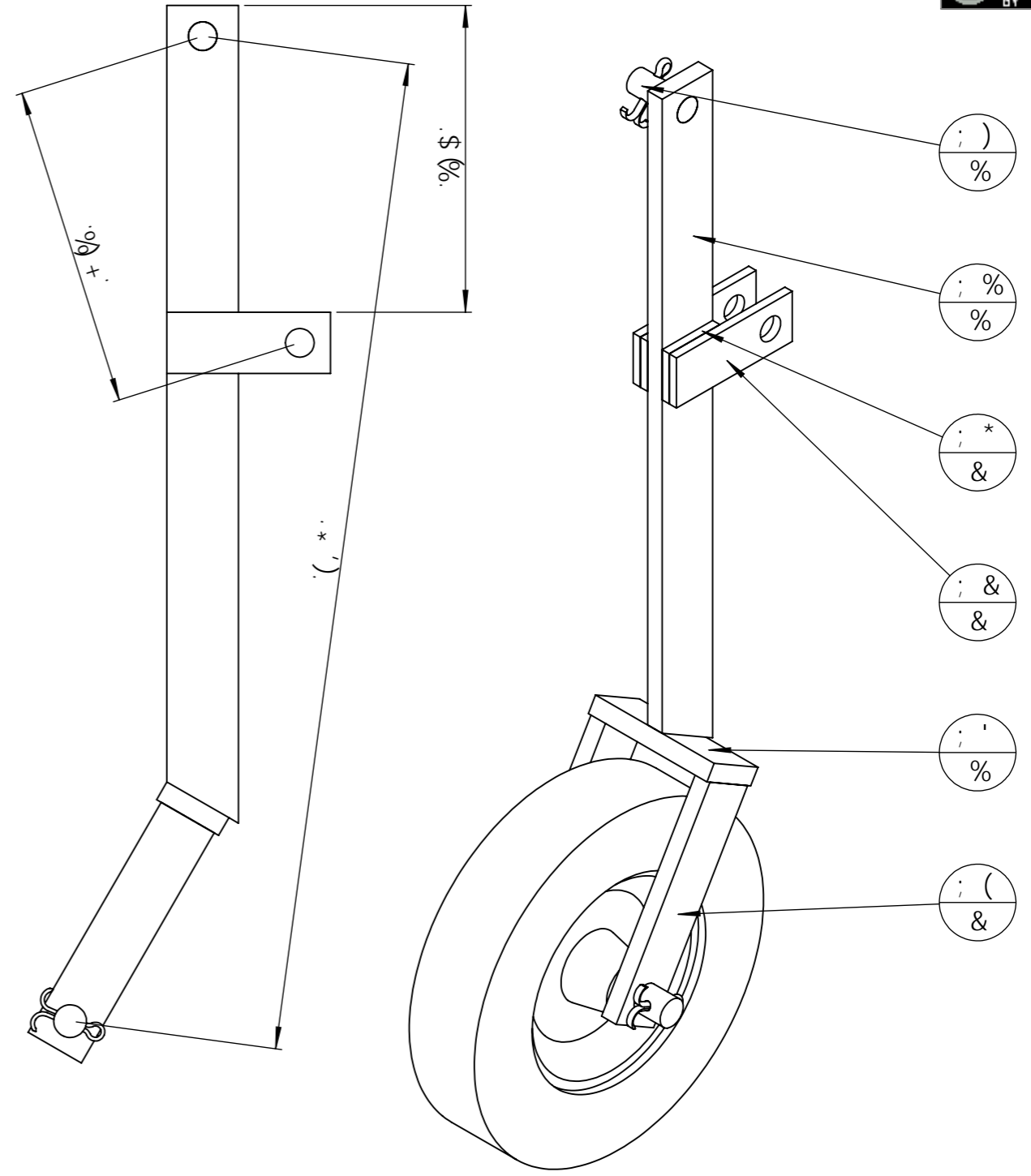
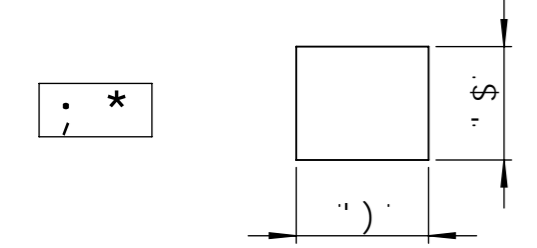
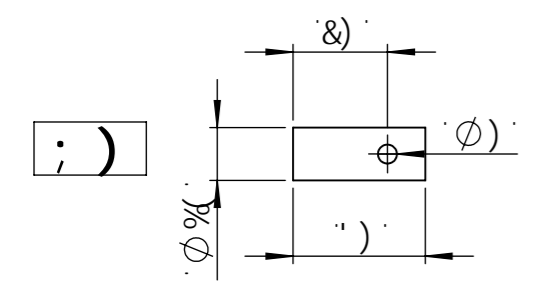
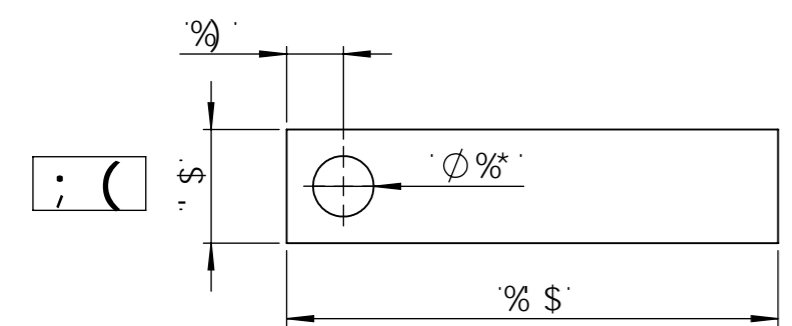
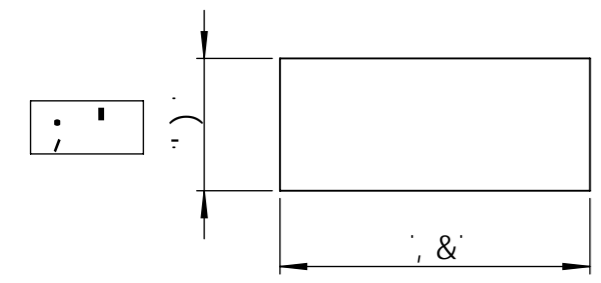
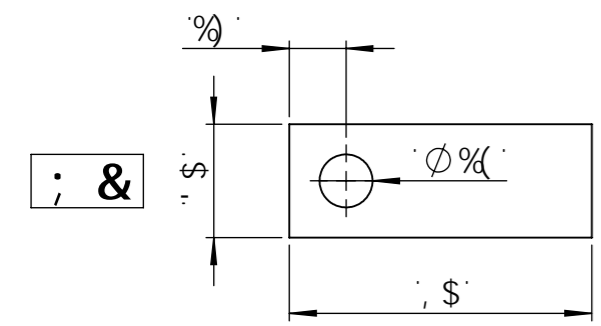
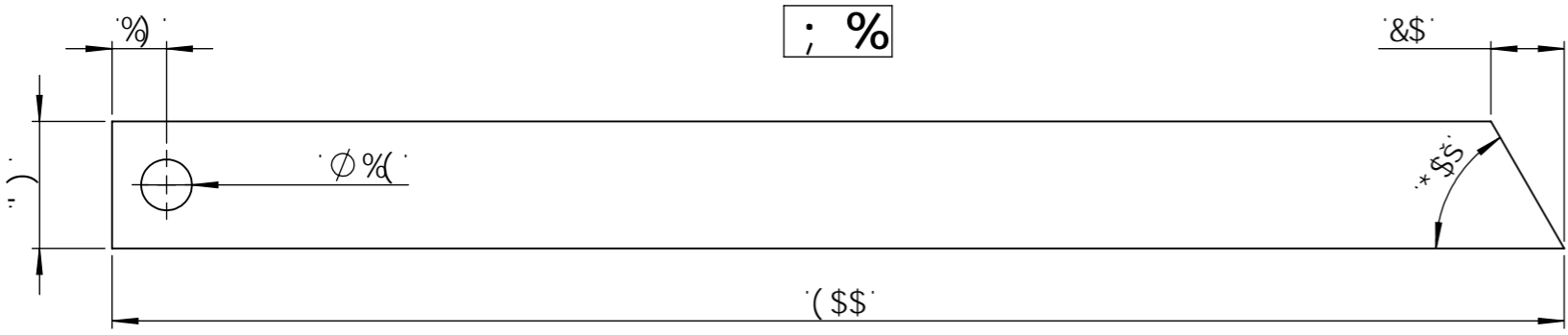

Bš	8 fg] bUh]cb	@b[i Yi f	E hf
; %	: Yfd'Uh') l '%\$	(\$\$	%
; '	: Yfd'Uh') l '%\$, &	%
; (f h]f 'd'Uh' \$l '%\$	% \$	&
;)	f h]f 'fcbX' « %	')	%
Fci Y	fci Y'WUci h\ci W« &\$\$		%
; ci d]Y'ZbXi Y	; ci d]Y'ZbXi Y) l " \$		&
; &	: Yfd'Uh' \$l)	, \$	&
; *	: Yfd'Uh' \$l)	')	&
N%	: Yfd'Uh' \$l)	%\$	%
N%\$\$	f h]f 'fcbX' « %*	%\$\$	%

Ci h	6]bYi gY 'Bfc! D'UbYh		
8 UHY	%{ #%&#&\$%*	vW\Y`Y	%& dU[Y'bs'% '#%+
D], WY	<!?!'N		E hf %

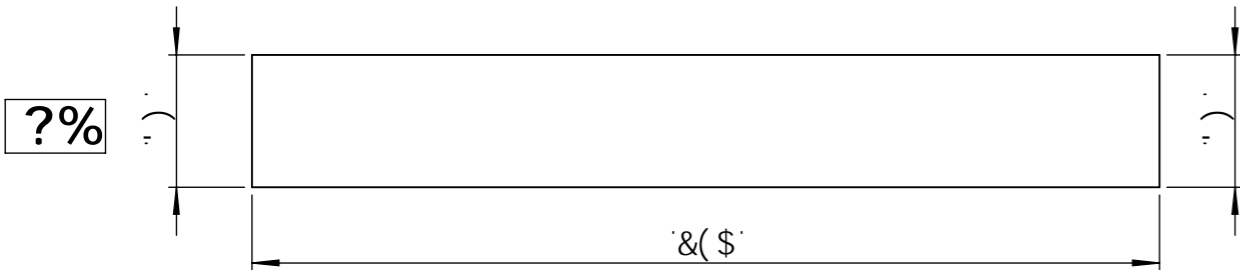
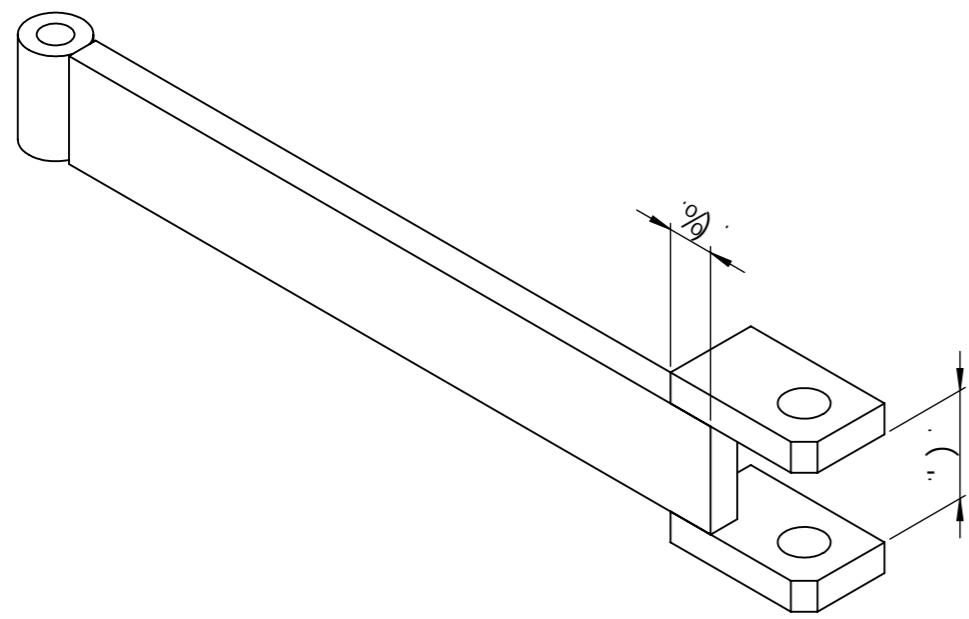

A Yi 'Yf'YgWc]bg'dci f'Y'dUggU[Y'XY'A

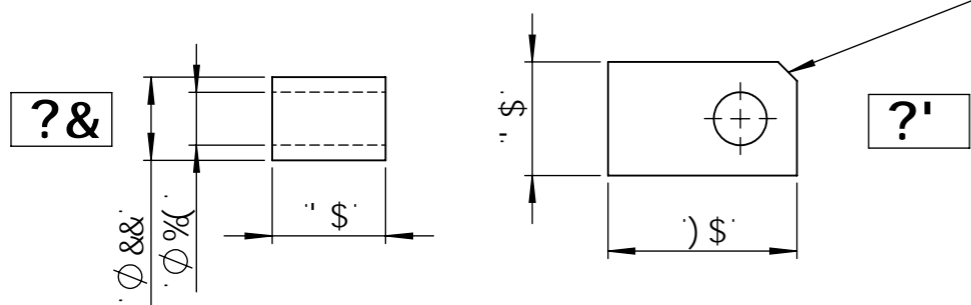

Bš	8fgl[bUhc b	@b[i Yi f	E hf
?%	:Yfd'Uh') l' %\$	&(\$	%
?&	h VY'fcbX' &\$' l')	%\$	%
?'	f hff' d'Uh' \$' l' %\$)\$	&

Bš	8fgl[bUhc b	@b[i Yi f	E hf
N%	:Yfd'Uh' \$' l')	%\$)
N()	f hff' fcbX' « %\$	()	&
N+)	f hff' fcbX' « %\$	+	%
N%\$\$	f hff' fcbX' « %*	%\$\$	%
N%&)	f hff' fcbX' « %\$	%&)	%

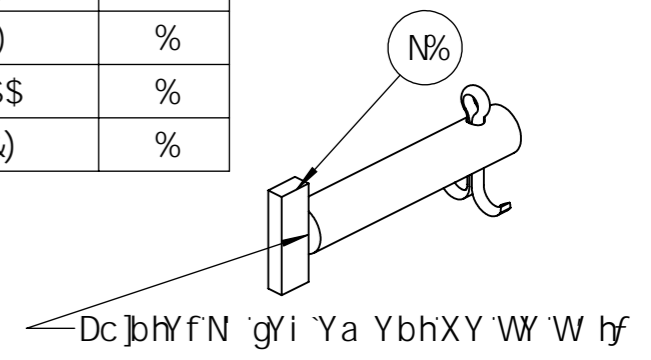
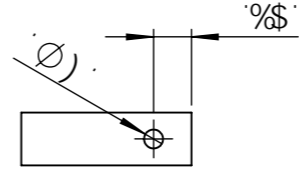

<
I &
fIYj]Yfgk

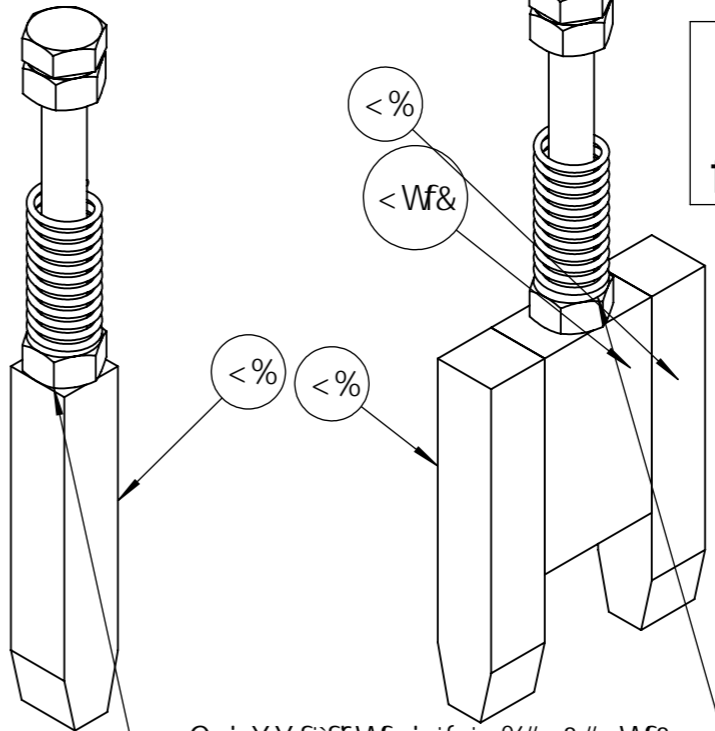

<Wf
I %
fWfL

<hf
I &
fhkL

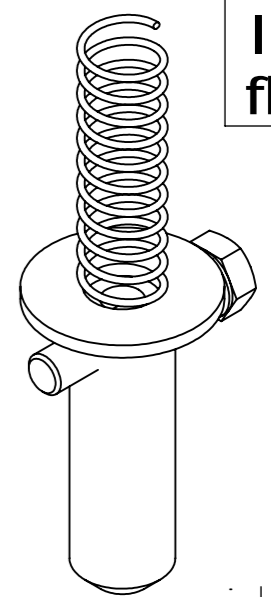

Gci XYf'ffWfci { <%#&#<Wf&
Gci XYf'ffWfci { <%#&#<Wf&

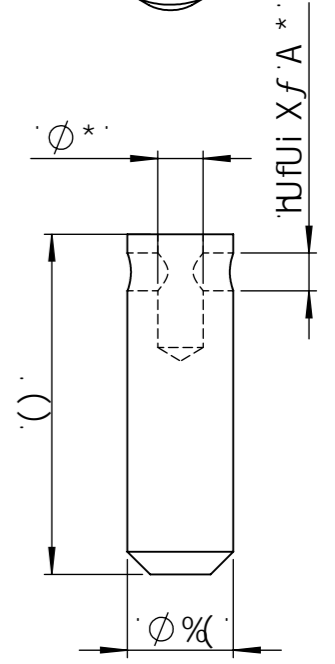
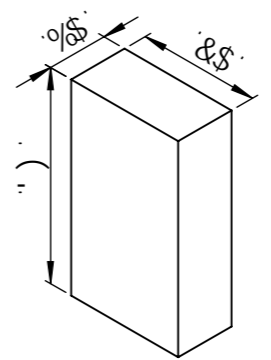
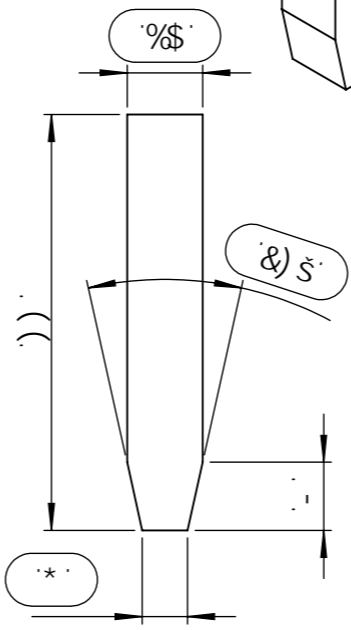

<%

<Wf&

<'



@

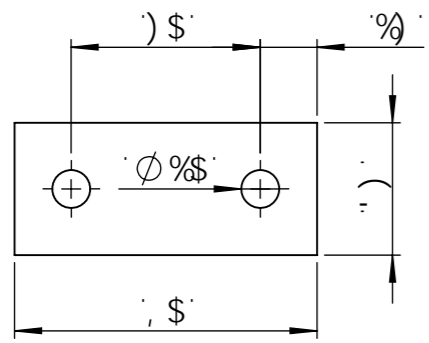

@

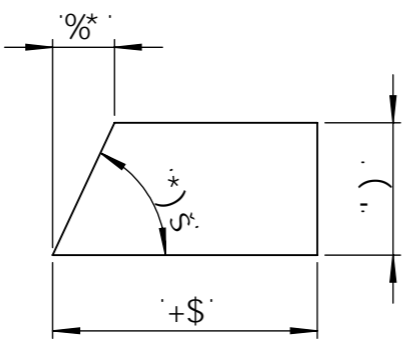

@

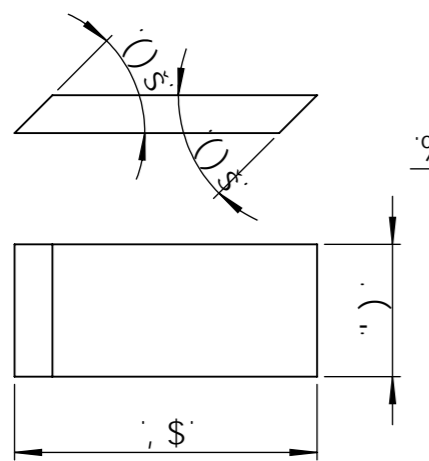

@

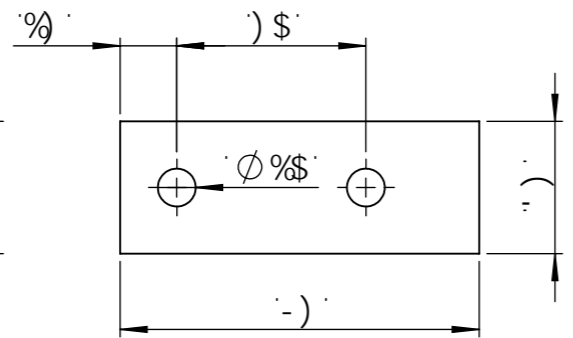

@/\$

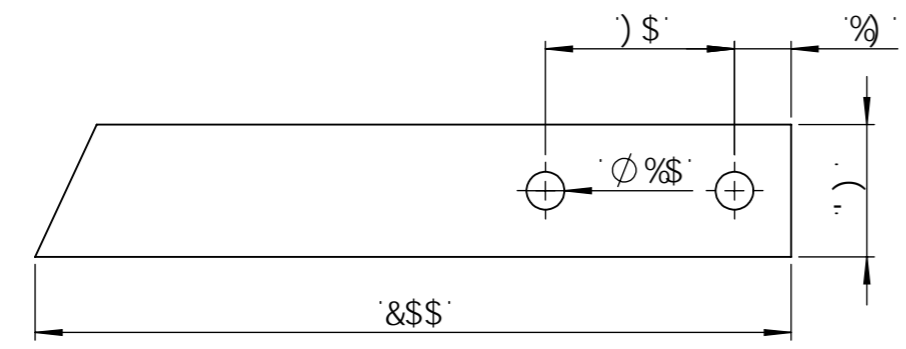

@/%

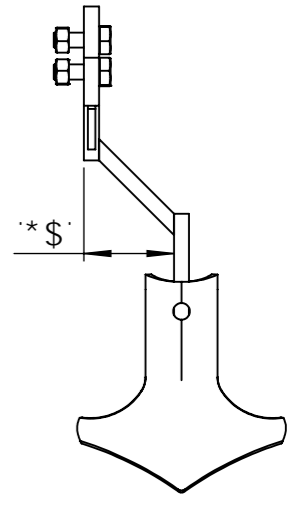
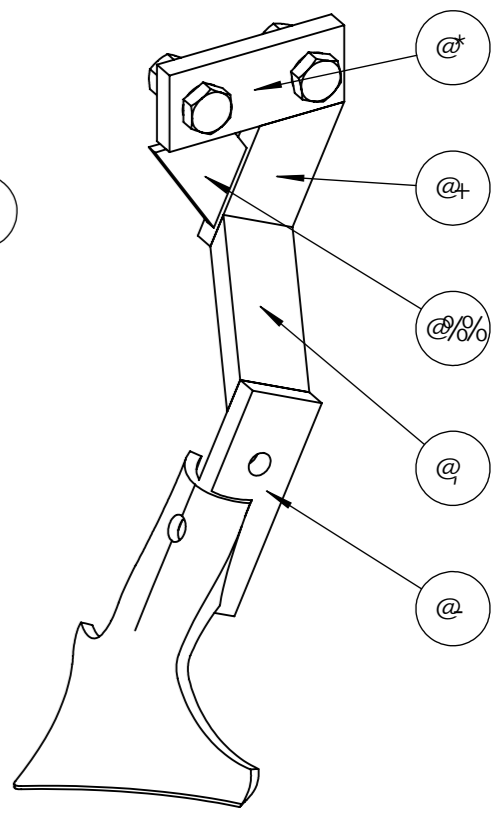
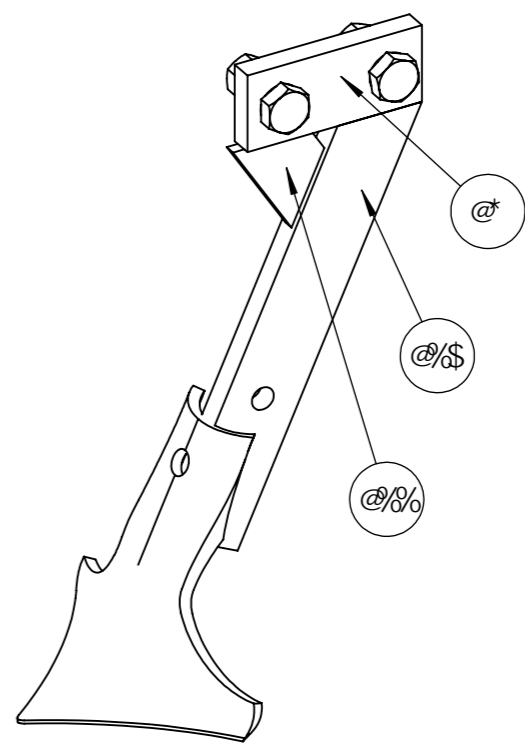
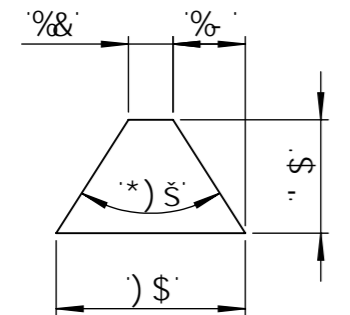

Bš	8fg[bU]cb	@b[iYif	E hf
@	:Yfd`Uh') l`%\$, \$	%
@+	:Yfd`Uh') l`%\$	+\$	%
@	:Yfd`Uh') l`%\$, \$	%
@	:Yfd`Uh') l`%\$	-)	%
@/\$:Yfd`Uh') l`%\$	&\$\$	%
@/%	:Yfd`Uh' \$l`))\$	%

Ci h	6]bYi gY 'Bfc! D'UbyYh		
8UH	%{ #%&#&\$%*	vWXY`Y	%& dU[Y'bs'%) #'%+
D], WY	A	E hf	%

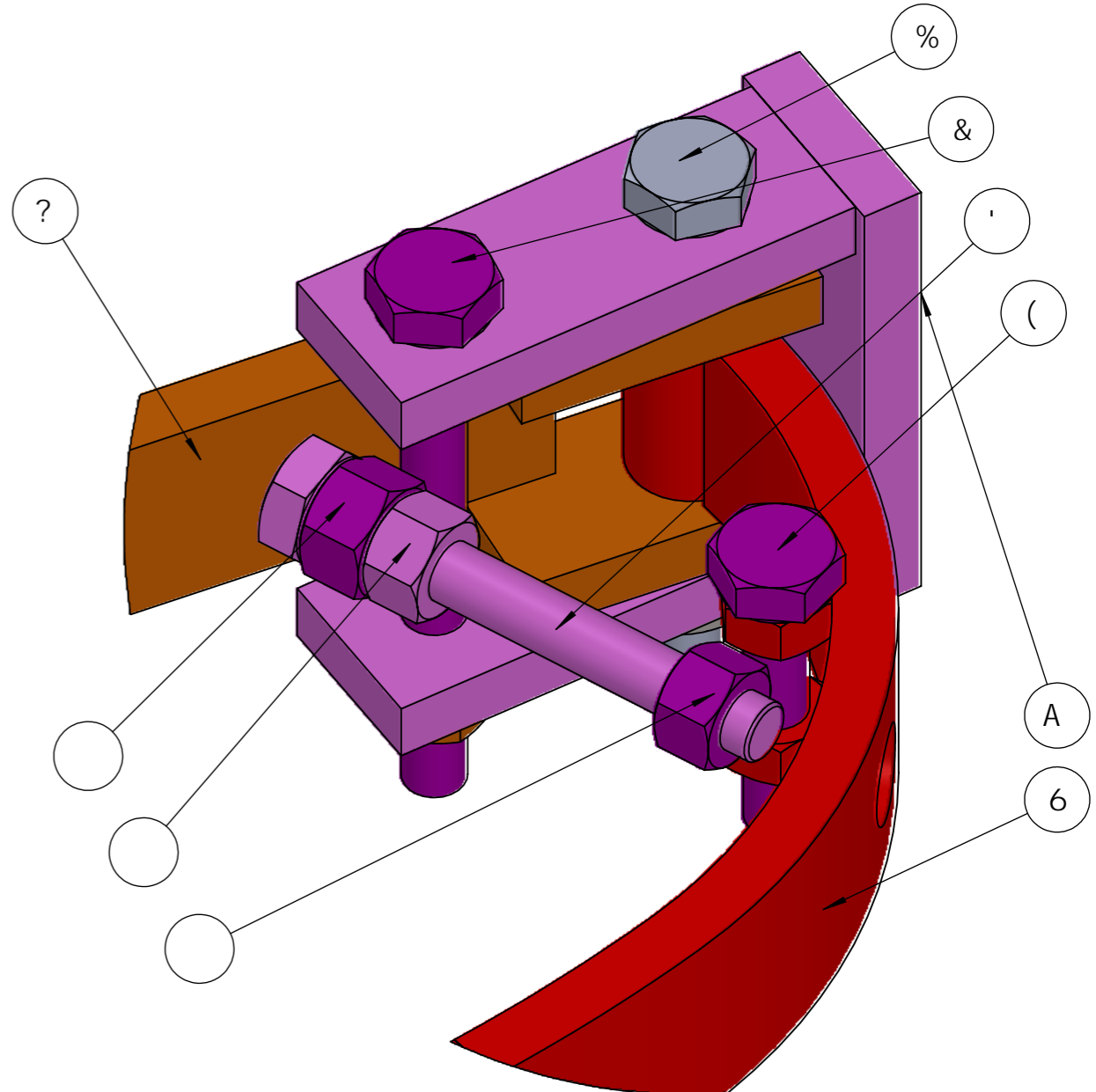
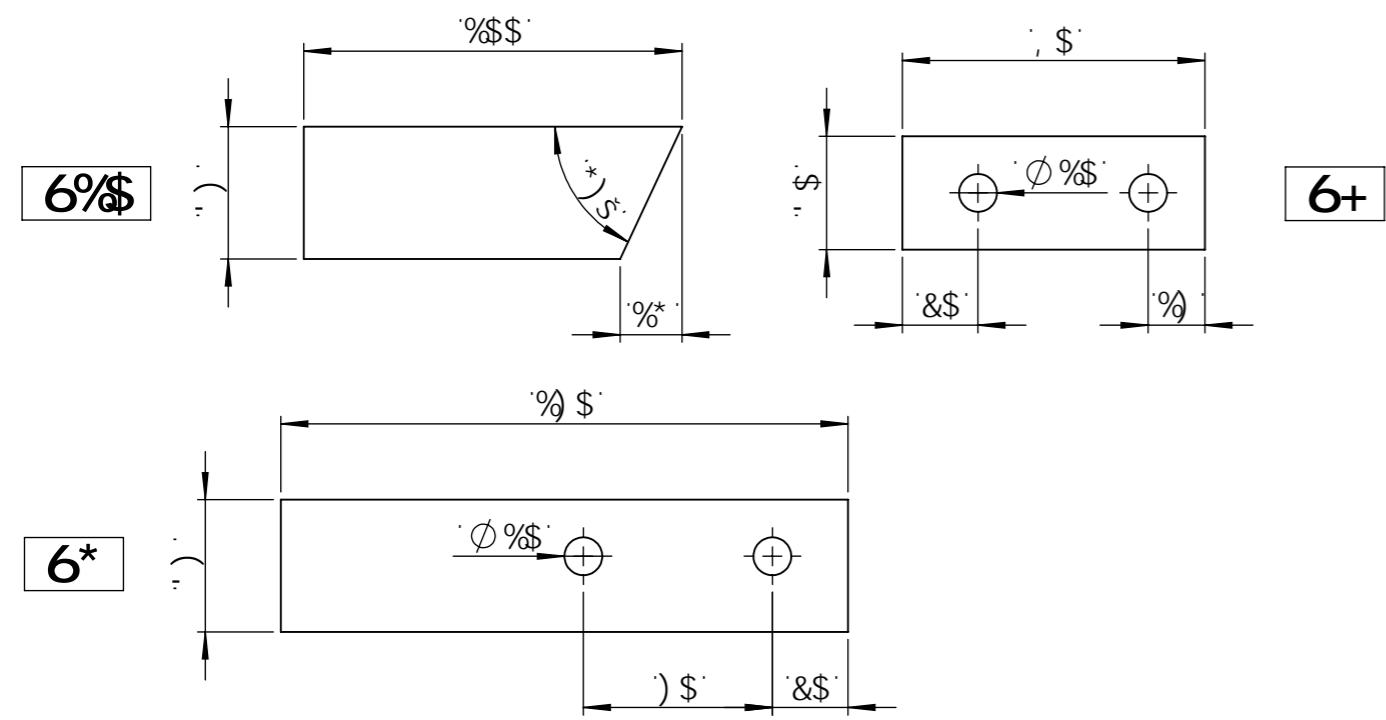
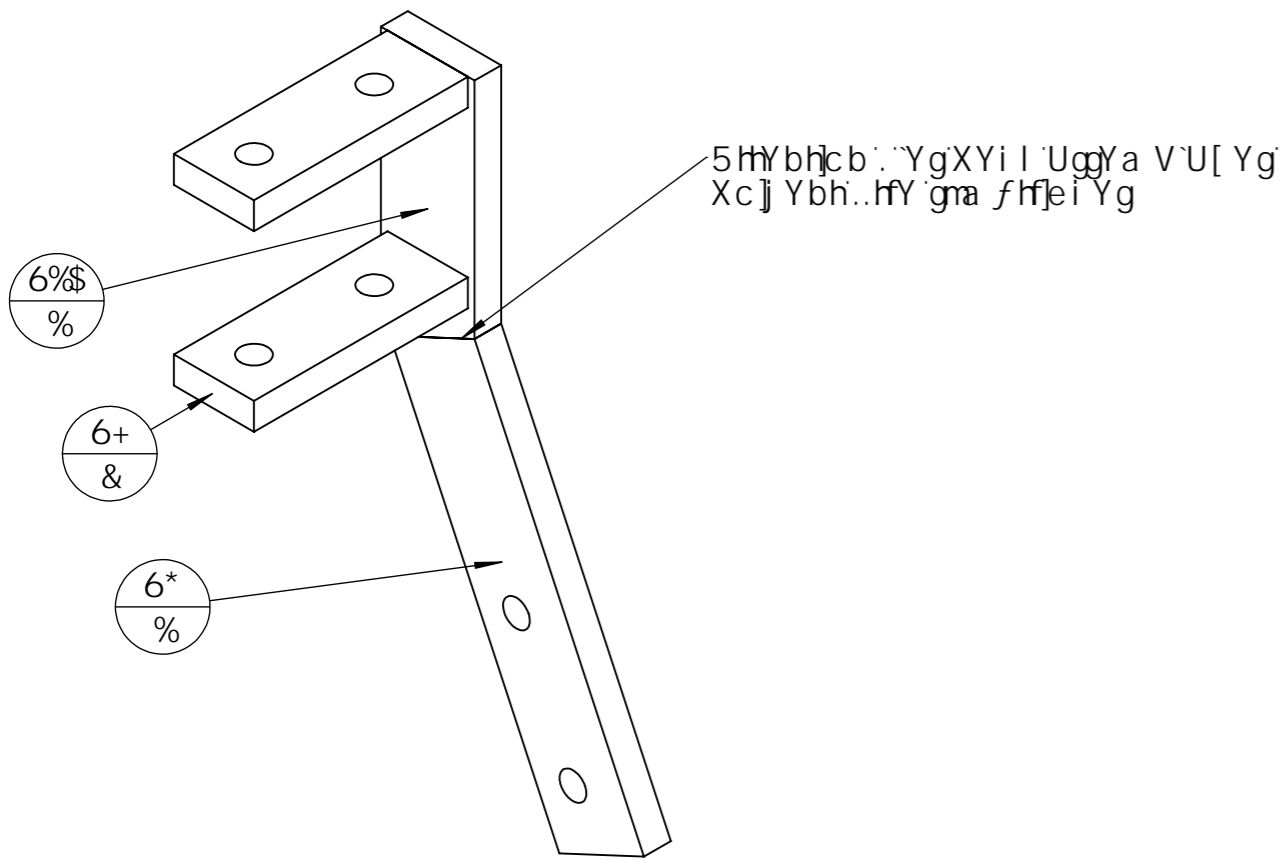

Bš	8fgl[bUh]cb	@b[i Yi f	E hf
6%\$:Yfd'Uh') i %\$	%\$\$	%
6+	fh]f'd'Uh' \$ i %\$, \$	&
6*	:Yfd'Uh') i %\$	%)\$	%

Ži > «±«a' ! ... -š--j : °\$²i®'i--š°°i -Yi !
 i--š°°i -Yi Ži°š> šf±j Yi
 ž ě@±' ! > @° j -°-«±YĚš±» «±«a' !
 ž ě@±' ! > @° j -°-«±YĚš±» «±«a' !
 ži > «±«a' ! ... -š--j Y @° j a° Ys a- ě@±' .
 i -°² Y-ĚYs a- ě@±' -«±®j @Ěšfj i °e a°® j i®Ě
 -š® ě@±' -«±®j > «ošfj

C i h̃	6]bYi gY 'Bfc! D'UbYh			
8 UH̃	%{ #/ & # & \$ % *	v W̃ Y ` Y	% & \$	d U [Y ' b s ` % * # % +
D] , W̃	Bca YbWUhi fY ' ! ' H̃			E h̃ %



Bš	8 f g [b U h c b	@ b [i Y i f	E h̃
5%	: Y f d ` U h ') ` % \$	+ \$ \$	&
5 &	f h j f f ` d ` U h ' \$ ` % \$	% (\$	&
5'	f h j f f ` d ` U h ' \$ ` % \$	% \$ \$	&
5(: Y f d ` U h ') ` % \$	+ \$	&
5+	: Y f d ` U h ') ` % \$	- \$	%
6% X	: Y f d ` U h ') ` % \$	& + & z + \$	%
6% [: Y f d ` U h ') ` % \$	& + & z + \$	%
6 &	: Y f d ` U h ') ` % \$	% % z % %	&
6'	: Y f d ` U h ' \$)	- \$	&
6(h i V Y f c b X ` & \$)	% \$	(
6*	: Y f d ` U h ') ` % \$	% \$	&
6+	f h j f f ` d ` U h ' \$ ` % \$, \$	(
6% \$: Y f d ` U h ') ` % \$	% \$ \$	&
7 %	f h j f f ` d ` U h ' \$ ` % \$	% \$ \$	&
7 &	: Y f d ` U h ') ` % \$	')	&
7'	f h j f f ` d ` U h ' \$ ` % \$	')	&
7 f f a U] , f Y ` Y j] Y f g	7 f f a U] , f Y ` Y j] Y f g		&
8 f %	: Y f d ` U h ') ` % \$	%)	%
8 f &	f h j f f ` d ` U h ' \$ ` % \$	' \$)	&
8 f'	: Y f d ` U h ' \$)	& + \$	&
8 f(f h j f f ` d ` U h ' \$ ` % \$) \$	&
8 f +	f h j f f ` c b X ` «)	% \$	%
8 f,	f h j f f ` c b X ` «)	(,)	%
9 %	: Y f d ` U h ' \$)	&)	&
9 &	: Y f d ` U h ' \$)	& ' \$	&
9 & 8	f h j f f ` d ` U h ' \$ ` % \$	& ' \$	%
9 &	f h j f f ` d ` U h ' \$ ` % \$	& ' \$	%
9'	: Y f d ` U h ') ` % \$	% \$	(
9(X	f h j f f ` c b X ` « % (' \$	%
9([f h j f f ` c b X ` « % ((\$	%
9)	h i V Y f c b X ` & \$)	' \$ \$	&
9*	f h j f f ` c b X ` «)	'))	&
9 W f c i	9 W f c i ` A * V f i h		+
9 W f c i	9 W f c i ` A % \$ V f i h		%
9 W f c i	9 W f c i ` A % \$ U i h c Z Y] b f		% \$
9 W f c i	9 W f c i ` A % & V f i h		&
: % %	f h j f f ` d ` U h ' \$ ` % \$	& ()	%
: % &	f h j f f ` d ` U h ' \$ ` % \$	%)	%
: & %	: Y f d ` U h ' \$)	+ & \$	%
: & &	f h j f f ` d ` U h ' \$ ` % \$	* \$	%
: & "	f h j f f ` d ` U h ' \$ ` % \$	% \$ \$	%

Bš	8 f g [b U h c b	@ b [i Y i f	E h̃
; %	: Y f d ` U h ') ` % \$	(\$ \$	%
; &	: Y f d ` U h ' \$)	, \$	&
; '	: Y f d ` U h ') ` % \$, &	%
; (f h j f f ` d ` U h ' \$ ` % \$	% \$	&
;)	f h j f f ` c b X ` « % (')	%
; *	: Y f d ` U h ' \$)	')	&
; c i d] Y Z b X i Y	; c i d] Y Z b X i Y) ' \$,
< %	X Y b h X Y W f a U] , f Y	% \$	&
<'	f h j f f ` c b X ` « % \$	()	&
# f %	: Y f d ` U h ') ` % \$	% \$	%
# f &	f h j f f ` d ` U h ' \$ ` % \$	%)	&
# f'	f h j f f ` d ` U h ' \$ ` % \$	&) \$	&
# f(: Y f d ` U h ' \$)	% \$	%
> f %	: Y f d ` U h ') ` % \$	% * \$	%
> f &	f h j f f ` d ` U h ' \$ ` % \$	' *	&
> f'	: Y f d ` U h ' \$)	' *	&
> f(f V U i W X Y ` h V i ` U] f Y ` & \$)	& \$	&
> f)	: Y f d ` U h ' \$)	&)	&
> f*	: Y f d ` U h ' \$)	% (&
? %	: Y f d ` U h ') ` % \$	& (\$	&
? &	h i V Y f c b X ` & \$)	% \$	&
?'	f h j f f ` d ` U h ' \$ ` % \$) \$	(
@	: Y f d ` U h ') ` % \$, \$	(
@ \$: Y f d ` U h ') ` % \$	& \$ \$	(
@ %	: Y f d ` U h ' \$)) \$	(
A U b W X Y f c b	A U b W X Y f c b ` W] b h f f	% &) \$	&
F Y g g c f h	F Y g g c f h W c a d f Y g g [c b ` % ' , ' \$		&
F Y g g c f h	f Y g g c f h W c a d f Y g g [c b ` % ` % \$ (\$		&
F c b X Y ` Y	F c b X Y ` Y ` « % (g f f] Y ` N		&
F c b X Y ` Y	F c b X Y ` Y ` « % \$ g f f] @		*
F c i Y	f c i Y ` W U c i h W c i W « & \$ \$		%
G c W d U H Y ` X f i] Y	G c W d U H Y ` X f i] Y % \$) a a		*
J] g < Y I U [c b U Y	J] g \ Y I U [c b U Y ` A *) \$		&
J] g < Y I U [c b U Y	J] g \ Y I U [c b U Y ` A * ' \$		&
J] g < Y I U [c b U Y	J] g \ Y I U [c b U Y ` A % \$, \$		*
J] g < Y I U [c b U Y	J] g \ Y I U [c b U Y ` A % \$ % \$ \$		(
J] g < Y I U [c b U Y	J] g \ Y I U [c b U Y ` A % \$) \$		*
J] g < Y I U [c b U Y	J] g \ Y I U [c b U Y ` A % \$ ' \$,
N %	: Y f d ` U h ' \$)	% \$)
N ()	f h j f f ` c b X ` « % (()	&
N +)	f h j f f ` c b X ` « % (+)	%
N % \$ \$	f h j f f ` c b X ` « % *	% \$ \$	%
N % &)	f h j f f ` c b X ` « % (% &)	%

Ci h	6]bYi gY 'Bfc! D'UbYh		
8UH	%(#%&#&\$%*	vW\Y`Y	%&\$ dU[Y'bs'+#'+
D], WY	Bca YbWUhi fY! '7f		E hf %



Bš	8fgl[bUhc b	@b[i Yi f	E hf
5%	: Yfd`Uh') i`%\$	+\$	&
5&	f hff`d`Uh' \$i`%\$	%(\$	&
5(: Yfd`Uh') i`%\$	+\$	&
5+	: Yfd`Uh') i`%\$	-\$	%
5,	: Yfd`Uh' \$i`)	%\$	%
6%&	: Yfd`Uh') i`%\$	&+&ž+\$	%
6%[: Yfd`Uh') i`%\$	&+&ž+\$	%
6&	: Yfd`Uh') i`%\$	% %ž%	&
6'	: Yfd`Uh' \$i`)	-\$	&
6(hi VY`fcbX`&\$i`)	%\$	(
6*	: Yfd`Uh') i`%\$	%\$	&
6+	f hff`d`Uh' \$i`%\$, \$	(
6%\$: Yfd`Uh') i`%\$	%\$	&
7%	f hff`d`Uh' \$i`%\$	%\$	&
7&	: Yfd`Uh') i`%\$	')	&
7'	f hff`d`Uh' \$i`%\$	')	&
7 ffa U]`, fY`Yj]Yfg	7 ffa U]`, fY`Yj]Yfg		&
7 ffa U]`, fY`a UbWYfcb	Wffa U]`, fY`a UbWYfcb		&
8Wf%	: Yfd`Uh') i`%\$	%)	%
8Wf&	f hff`d`Uh' \$i`%\$	' \$\$	&
8Wf'	: Yfd`Uh' \$i`)	')\$	&
8Wf(f hff`d`Uh' \$i`%\$	(\$	&
8Wf)	: Yfd`Uh' \$i`)	% \$	%
8Wf*	: Yfd`Uh' \$i`))\$	%
8Wf+	f hff`fcbX`«)	%(\$	%
8Wf,	f hff`fcbX`«)	(')	%
9%	: Yfd`Uh' \$i`)	&	&
9&	: Yfd`Uh' \$i`)	&' \$	&
9&8	f hff`d`Uh' \$i`%\$	&' \$	%
9&:	f hff`d`Uh' \$i`%\$	&' \$	%
9'	: Yfd`Uh') i`%\$	%\$	(
9(X	f hff`fcbX`« %(\$	' \$	%
9([f hff`fcbX`« %(\$	(\$	%
9)	hi VY`fcbX`&\$i`)	' \$\$	&
9*	f hff`fcbX`«)	'))	&
9Wfci	9Wfci`A`*`Vfi`h		-
9Wfci	9Wfci`A`%\$`Ui`hc`ZY`]b`f		%&
9Wfci	9Wfci`A`%\$`Vfi`h		%*

Bš	8fgl[bUhc b	@b[i Yi f	E hf
9Wfci	9Wfci`A`%&`Vfi`h		&
: %%	f hff`d`Uh' \$i`%\$	&()	%
: %&	f hff`d`Uh' \$i`%\$	%)	%
: &%	: Yfd`Uh' \$i`)	+&\$	%
: &`&	f hff`d`Uh' \$i`%\$	*\$	%
: &`"	f hff`d`Uh' \$i`%\$	%\$\$	%
; %	: Yfd`Uh') i`%\$	(\$\$	%
; &	: Yfd`Uh' \$i`)	, \$	&
; '	: Yfd`Uh') i`%\$, &	%
; (f hff`d`Uh' \$i`%\$	% \$	&
;)	f hff`fcbX`« %(\$	')	%
; *	: Yfd`Uh' \$i`)	')	&
; ci d]`Y`ZYbXi`Y	; ci d]`Y`ZYbXi`Y`) i`" \$		-
<%	XYbhXY`Wffa`U]`, fY	%\$	(
<Wf&	: Yfd`Uh') i`%\$	&\$	%
?%	: Yfd`Uh') i`%\$	&(\$	&
?&	hi VY`fcbX`&\$i`)	%\$	&
?'	f hff`d`Uh' \$i`%\$)\$	(
@	: Yfd`Uh') i`%\$, \$	(
@/\$: Yfd`Uh') i`%\$	&\$	(
@/%	: Yfd`Uh' \$i`))\$	(
A UbWYfcb	A UbWYfcb`W]bhf`f	%&) \$	&
FYggc`fh	FYggc`fh`Wca`d`fYgg]`cb`%i`',`i`" \$		'
FcbXY`Y	FcbXY`Y`«`%\$`gf]Y`@		(
FcbXY`Y	FcbXY`Y`«`%(\$`gf]Y`A`I		&
Fci`Y	fci`Y`WUci`hWci`W«`&\$		%
GcWdUHY`X`f]Y	GcWdUHY`X`f]Y`%\$)a`a		*
J]g<YIU[`cbUY	J]g\YIU[`cbUY`A`*`i`) \$		'
J]g<YIU[`cbUY	J]g\YIU[`cbUY`A`%\$`i`" \$,
J]g<YIU[`cbUY	J]g\YIU[`cbUY`A`%\$`i`) \$		*
J]g<YIU[`cbUY	J]g\YIU[`cbUY`A`%\$`i`',`\$		*
J]g<YIU[`cbUY	J]g\YIU[`cbUY`A`%\$`i`%\$\$		(
N%	: Yfd`Uh' \$i`)	%\$	*
N()	f hff`fcbX`« %(\$	()	'
N+)	f hff`fcbX`« %(\$	+	%
N%\$\$	f hff`fcbX`« %*	%\$\$	&