

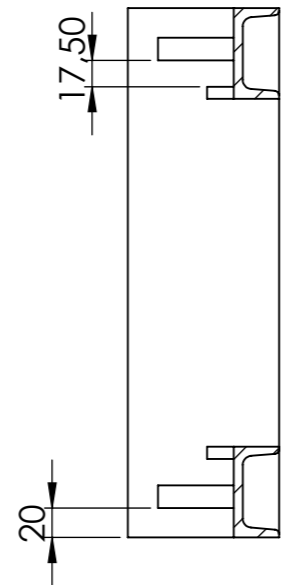

Version	1.0	Qté	1	
Date	26/10/2015			
Outil	Néo Bucher			
Pièce	Gabarit Cadre de brancard A1			

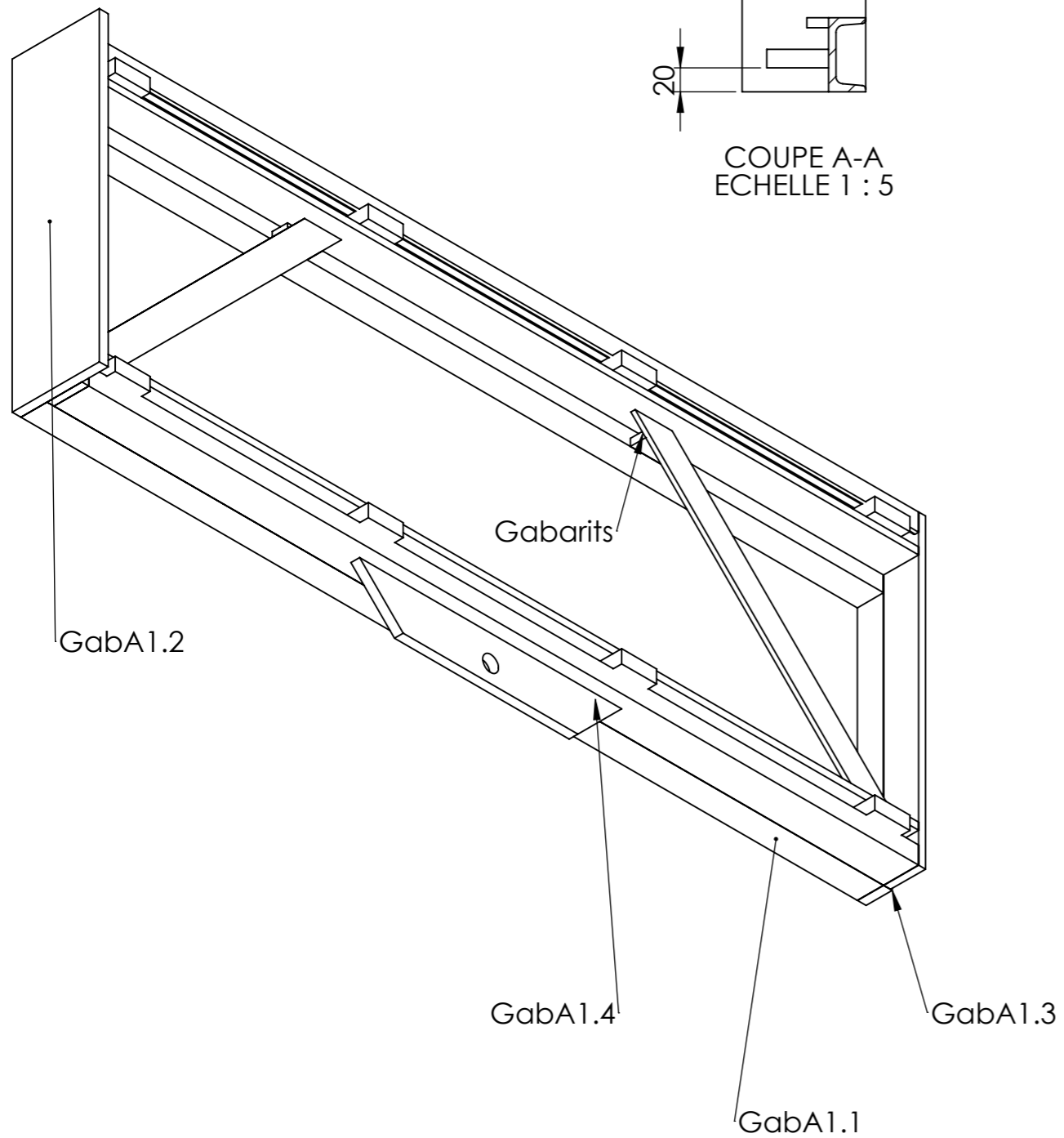

COUPE A-A
ECHELLE 1 : 5

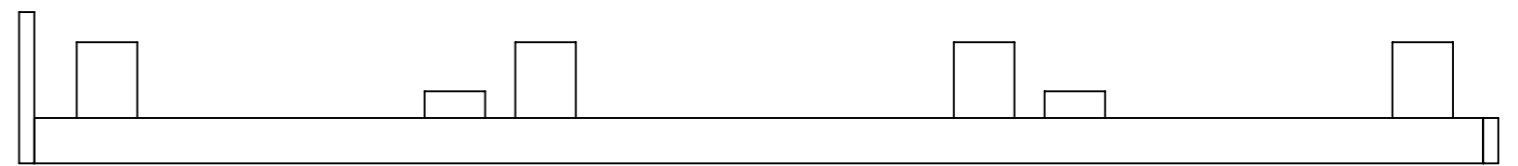
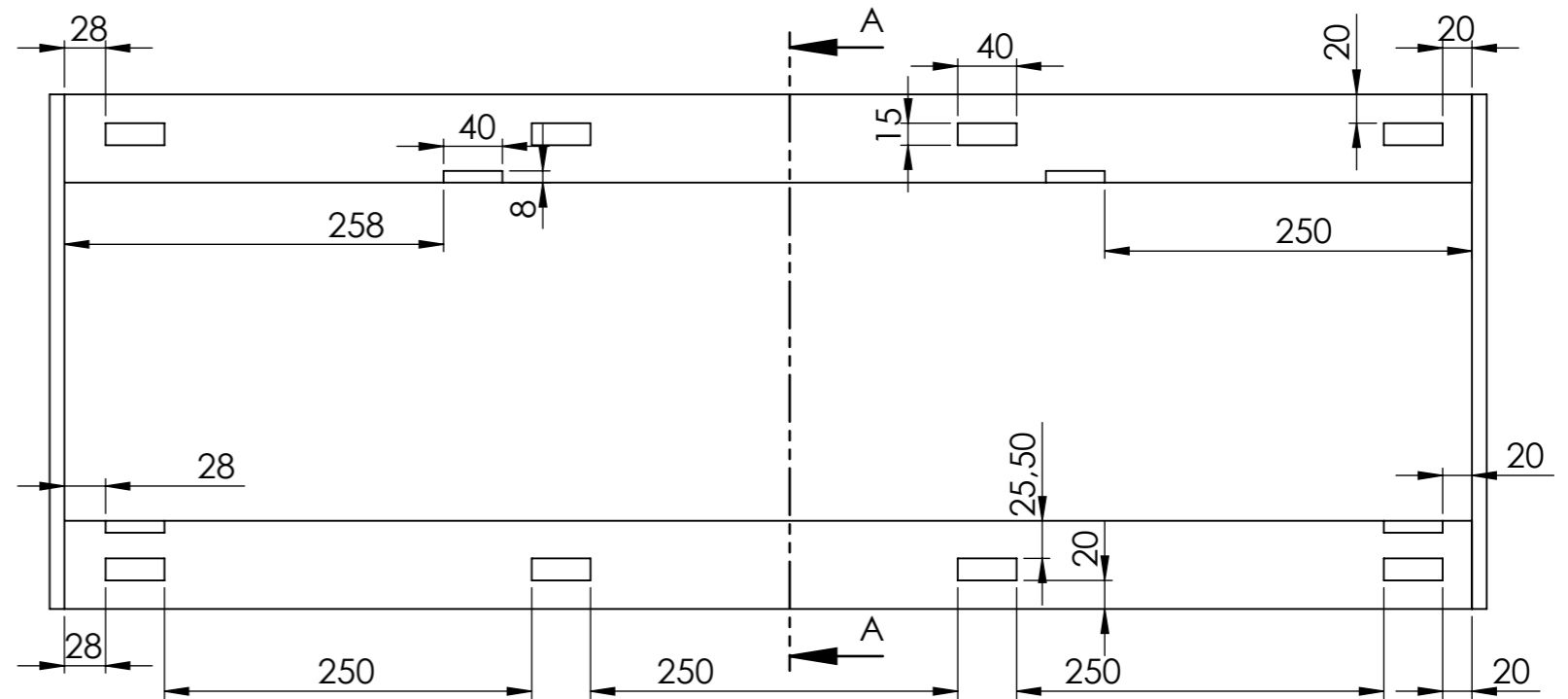

N°	Désignation	Longueur	Gabarit seul/Quantité
GabA1.1	Profilé UPN 60 x 30	958	2
GabA1.2	Fer plat 100 x 10	350	1
GabA1.3	Fer plat 30 x 10	350	1
GabA1.4	Fer plat 50 x 15	40	8
GabA1.5	Fer plat 50 x 15	17,50	1
GabA1.5	Fer plat 40 x 8	17,50	1

Version	1.0	Qté	1	
Date	26/10/2015			
Outil	Néo Bucher			
Pièce	Gabarit Châssis B1			

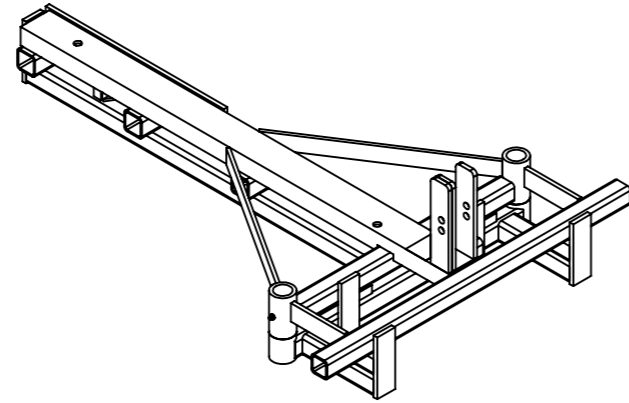

Goussets B5.1 identiques à ceux de l'assemblage B1.

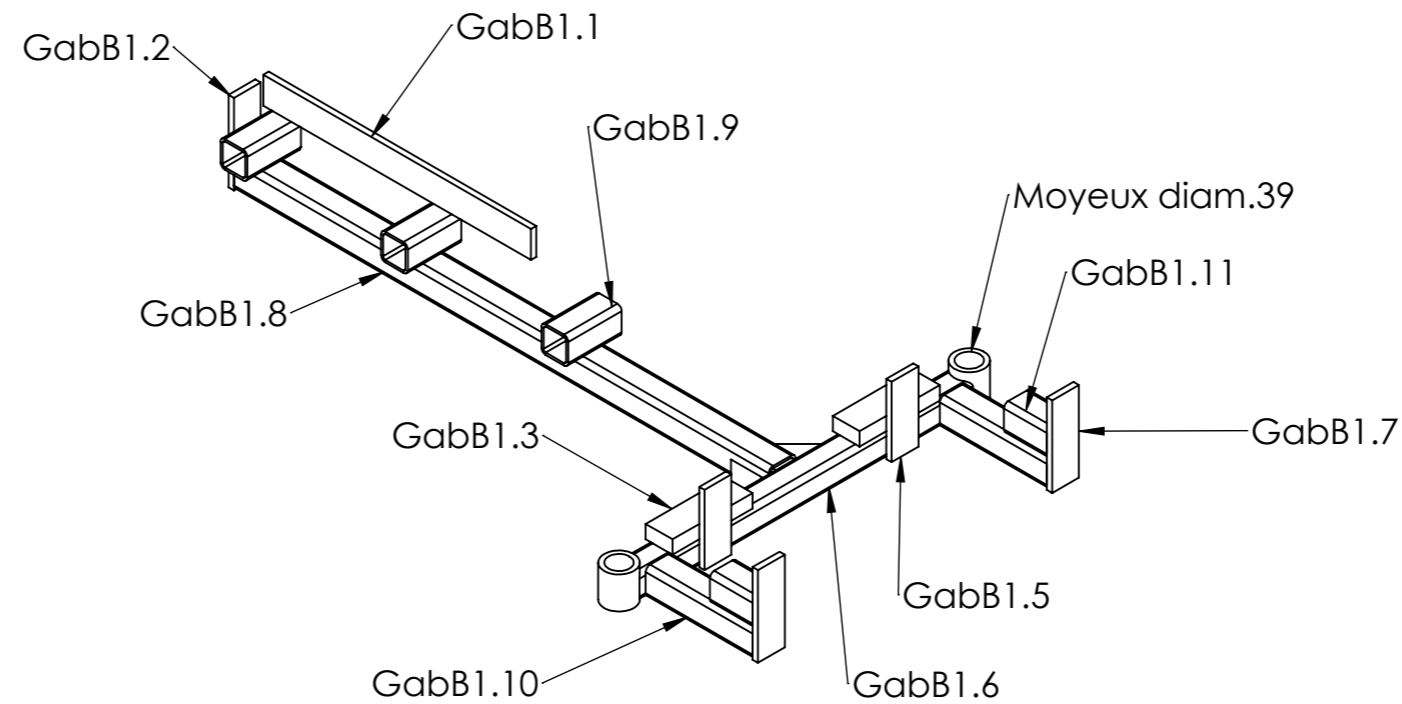
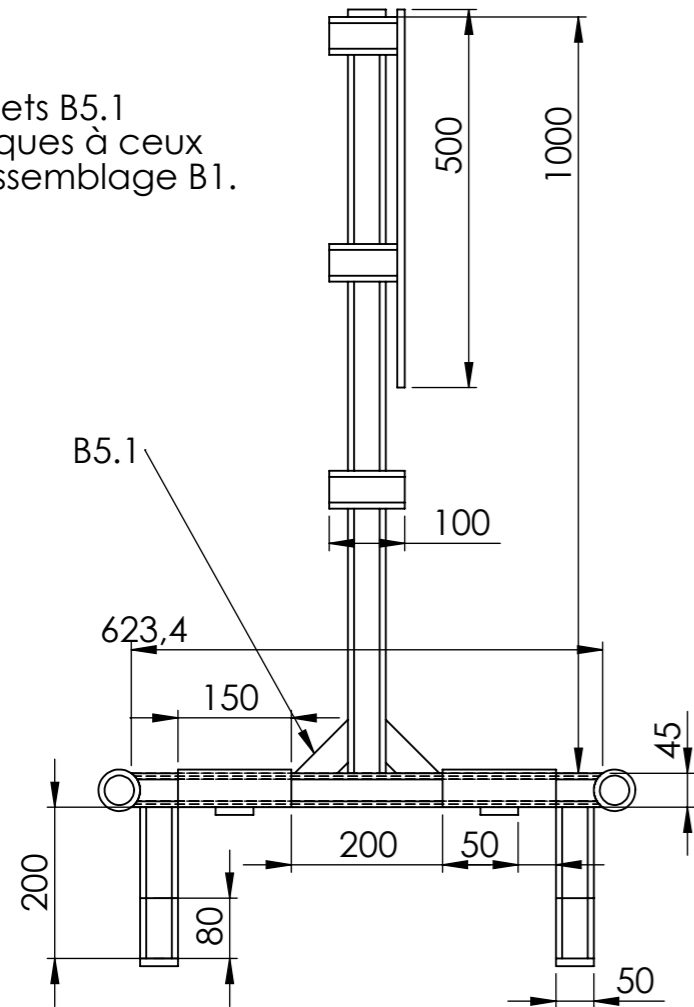

N°	Désignation	Longueur	Gabarit Seul	Quantité
Moyeux diam.39	Moyeu ext 55 int 35 l60			2
GabB1.1	Fer plat 50 x 10	500		1
GabB1.2	Fer plat 50 x 10	150		1
GabB1.3	Fer plat 50 x 25	150		2
GabB1.6	tube carré 45 x 4	640		1
GabB1.7	Fer plat 50 x 10	150		2
GabB1.8	tube carré 50 x 4	1000		1
GabB1.9	tube carré 50 x 4	100		3
GabB1.10	tube carré 50 x 4	200		2
GabB1.11	tube carré 50 x 4	80		2
GabB1.5	Fer plat 50 x 10	130		2
B5.1	Fer plat 40 x 8	100		2

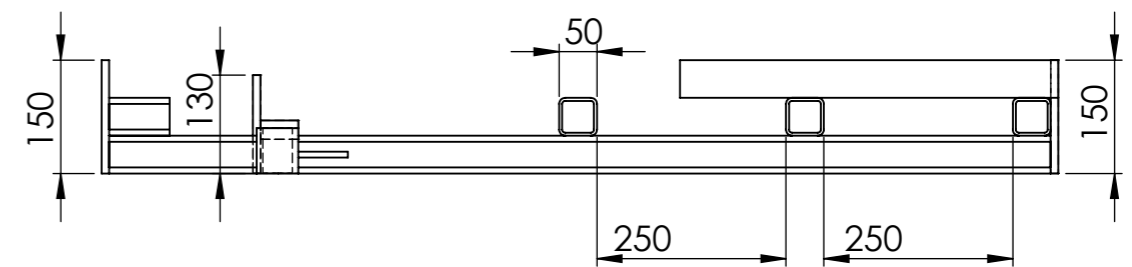
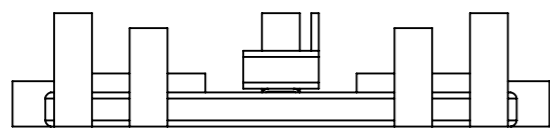

Version	2.0	Qté	1	
Date	15/12/2013			
Outil	Néo Bucher			
Pièce	Gabarit Supports de traverse porte-outils C1 et C2			

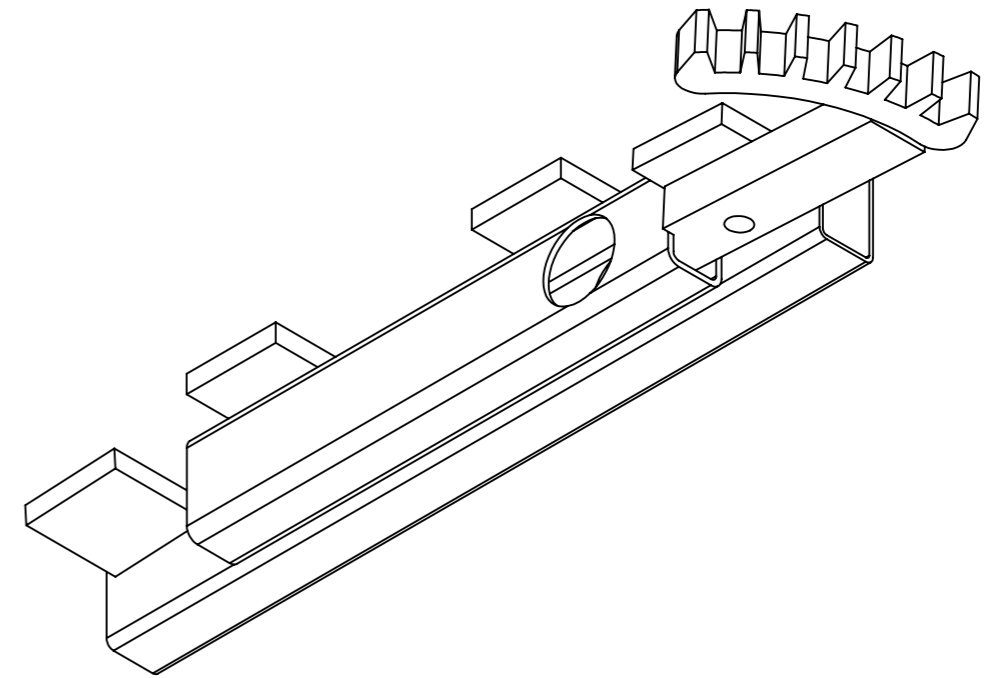
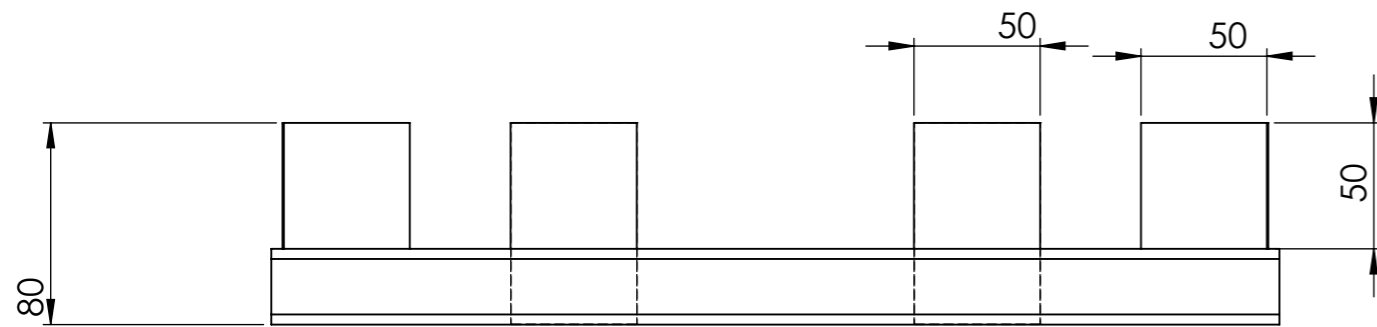
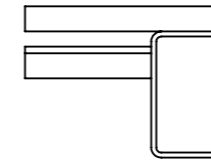
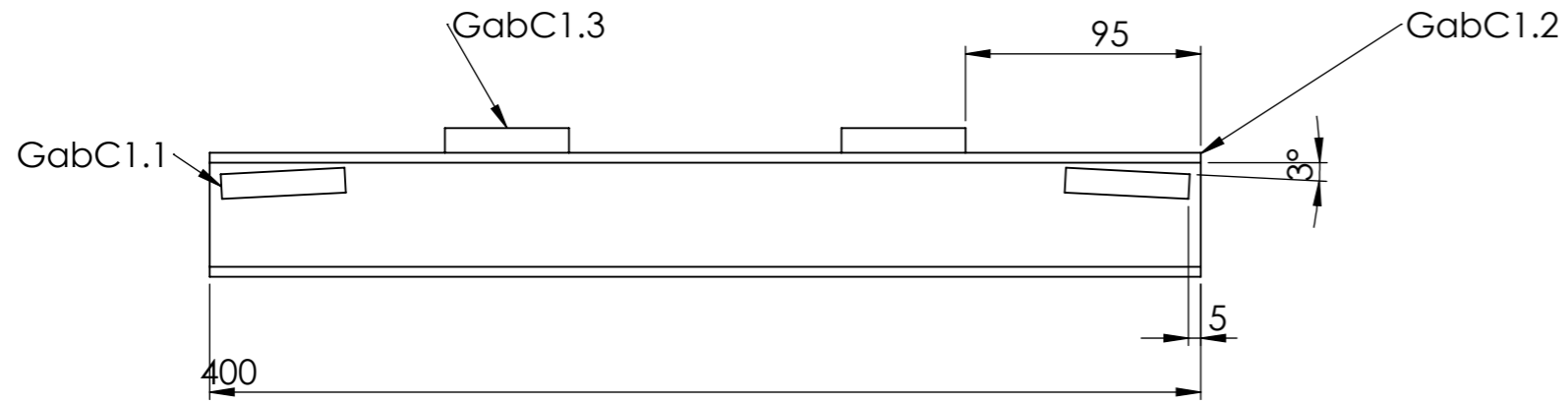

N°	Désignation	Longueur	Gabarit seul/Quantité
GabC1.1	Fer plat 50 x 10	50	2
GabC1.2	tube rectangulaire 50 x 30 x 2	400	1
GabC1.3	Fer plat 50 x 10	80	2

Version	1.0	Qté	1	
Date	26/10/2015			
Outil	Néo Bucher			
Pièce	Gabarit Brancard			



GabBrancard3 (x 2) :

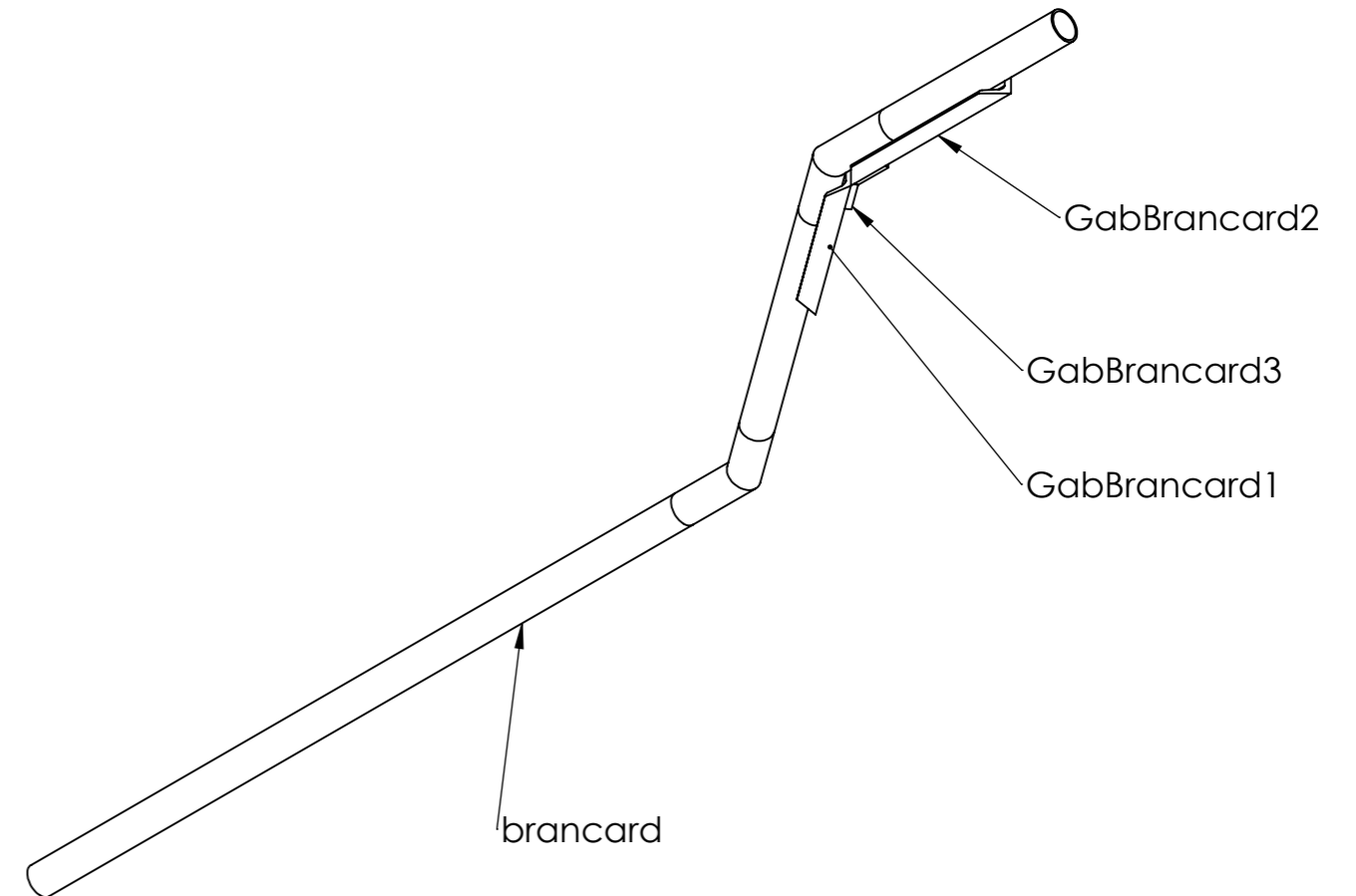
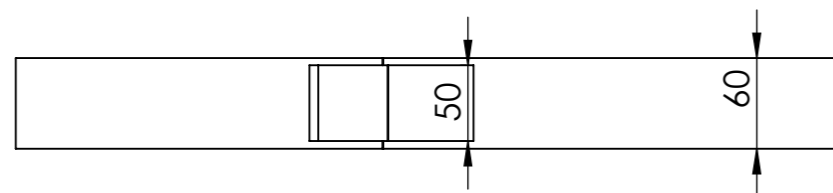
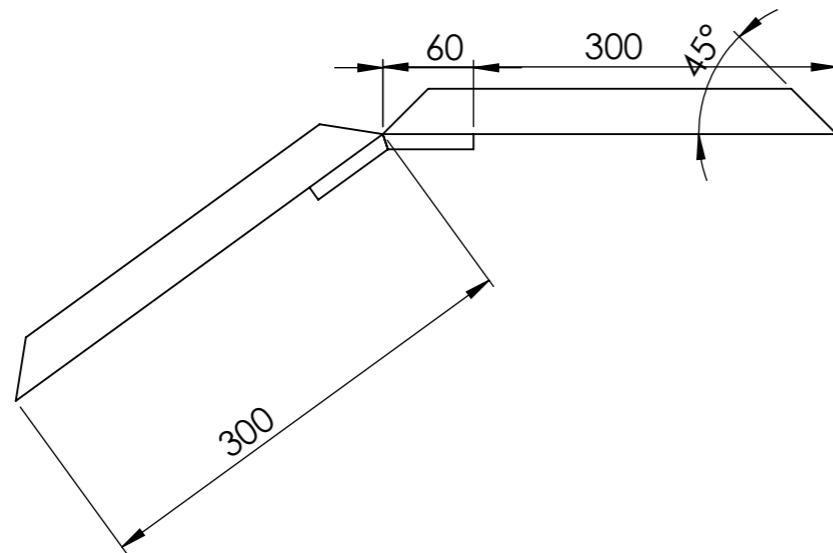
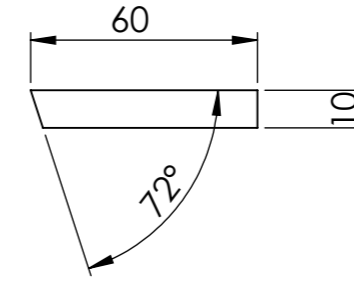

N°	Désignation	Longueur	Gabarit seul/Quantité
GabBrancard1	Profilé UPN 60 x 30	300	1
GabBrancard2	Profilé UPN 60 x 30	300	1
GabBrancard3	Fer plat 50 x 10	60	2

Version	1.0	Qté	1	
Date	26/10/2015			
Outil	Néo Bucher			
Pièce	Gabarit supports de fusée D1 et D2			

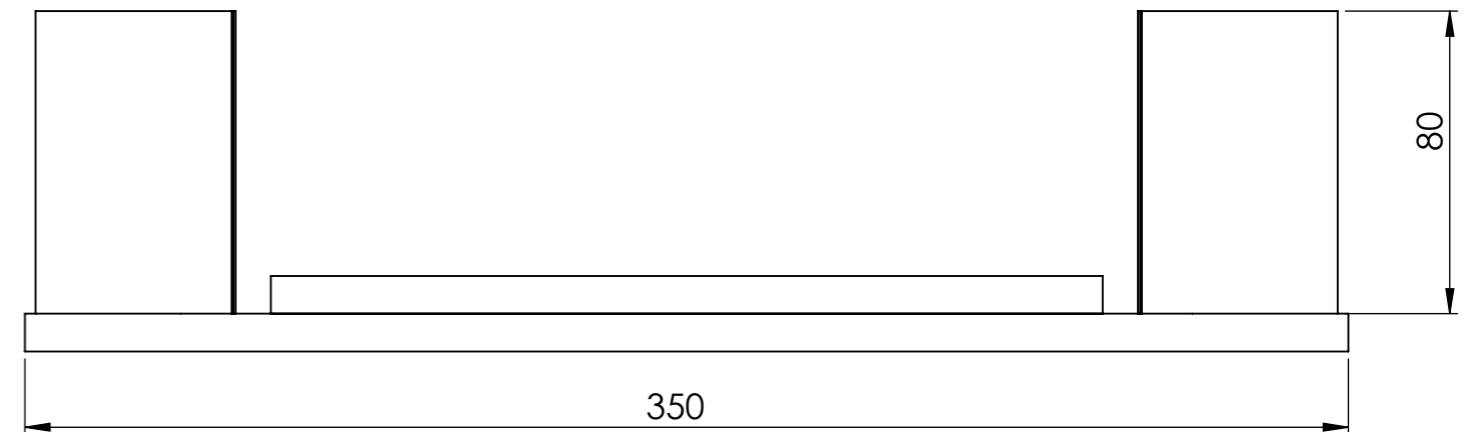
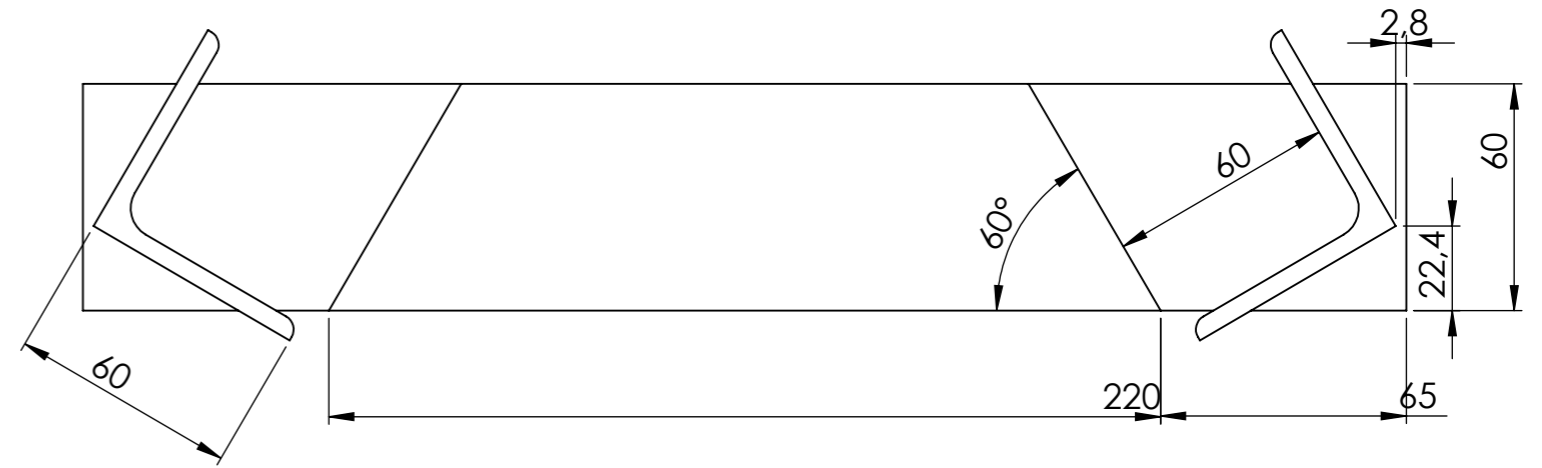
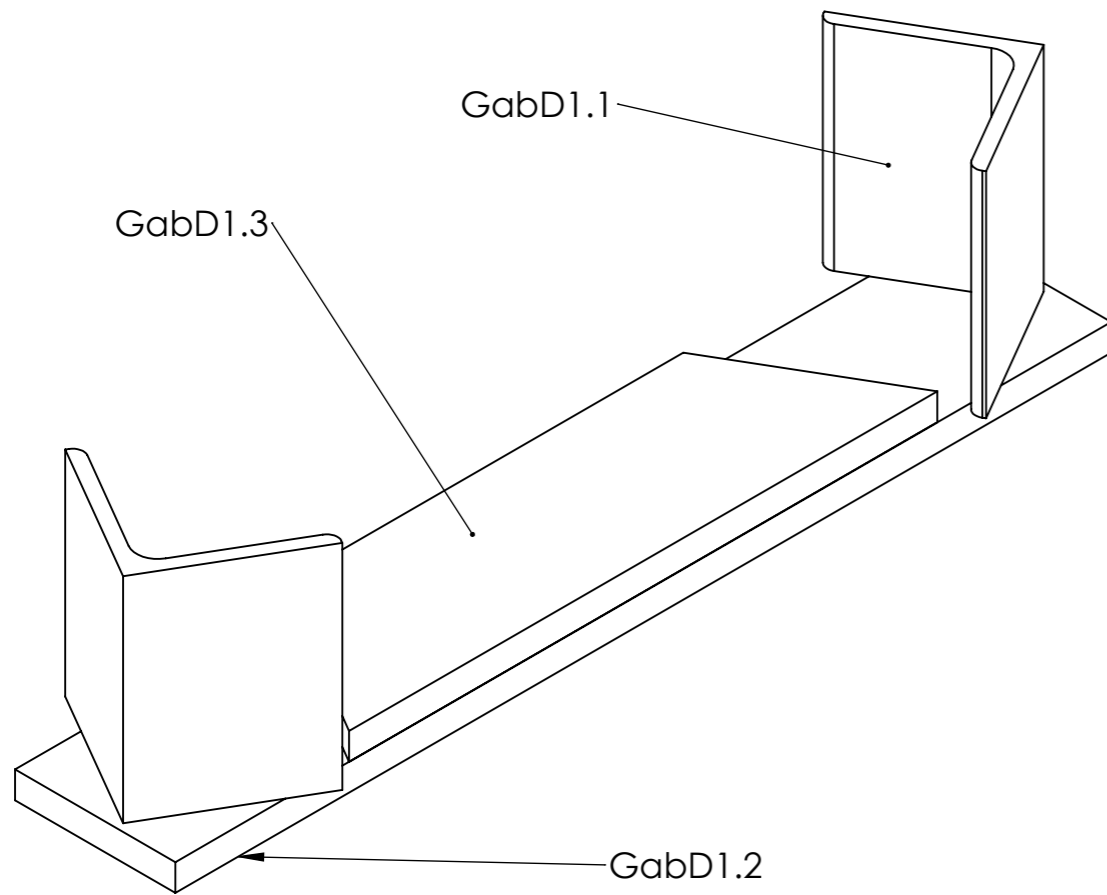
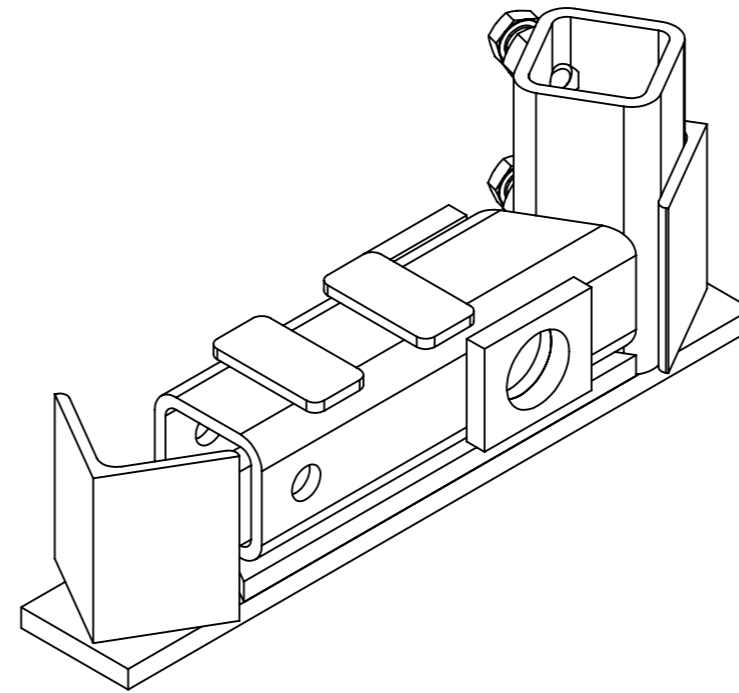

N°	Désignation	Longueur	Gabarit seul/Quantité
GabD1.1	Cornière 60 x 60 x 5	80	2
GabD1.2	Fer plat 60 x 10	350	1
GabD1.3	Fer plat 60 x 10	220	1

Version	1.0	Qté	1	
Date	26/10/2015			
Outil	Néo Bucher			
Pièce	Gabarit fusée gauche et droite E2 et E3			

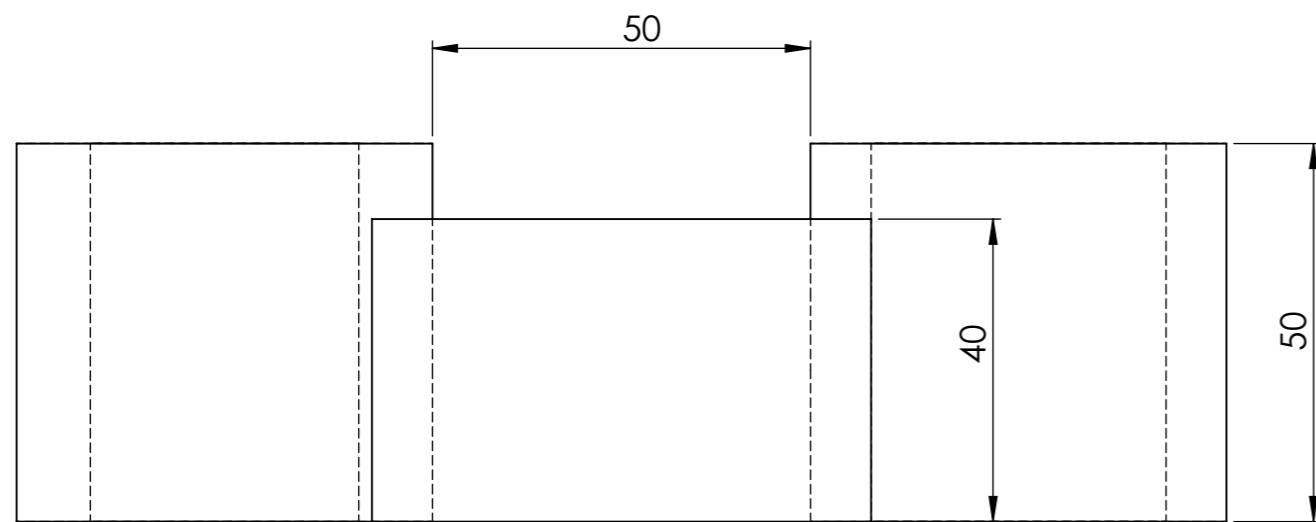
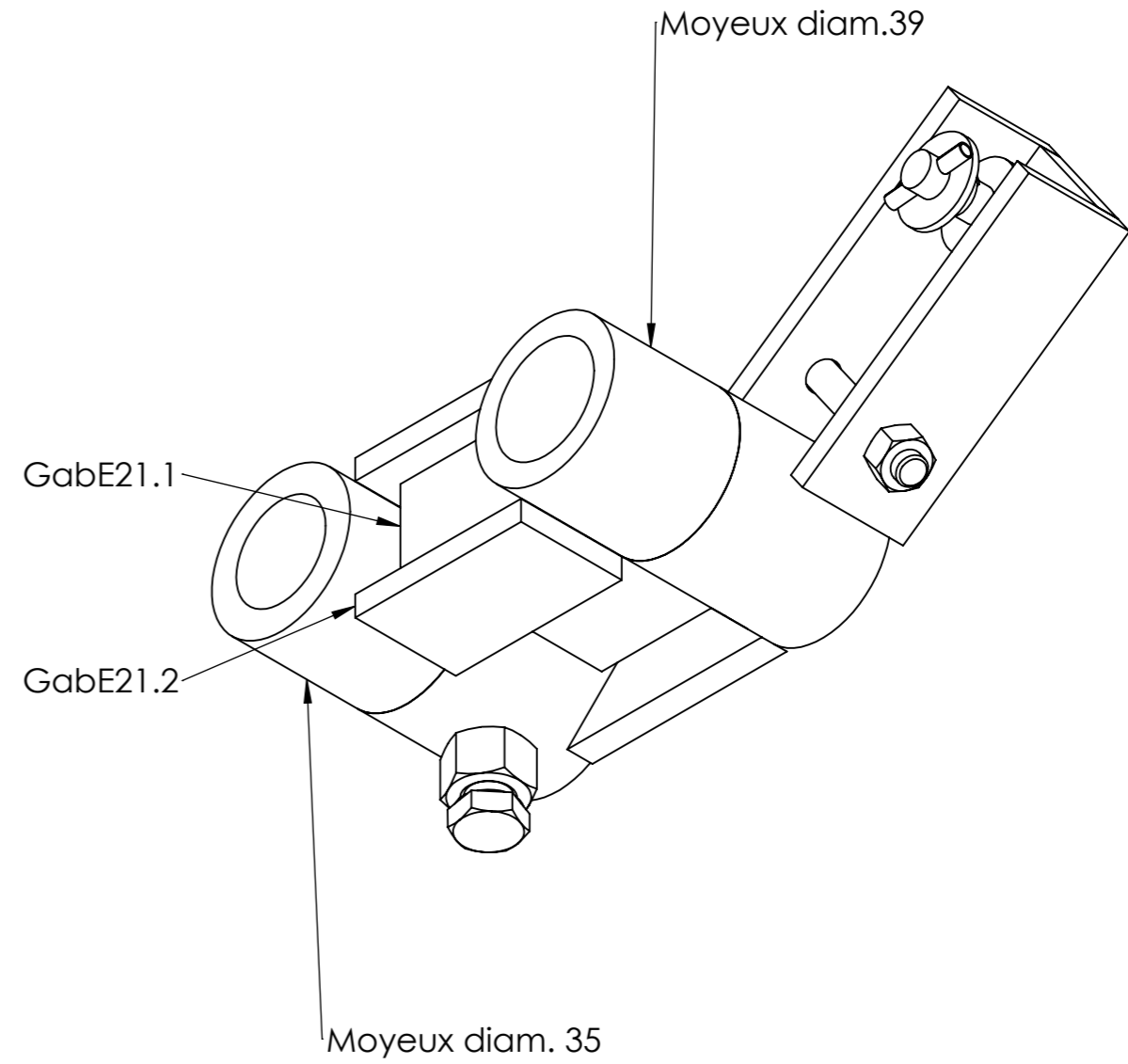
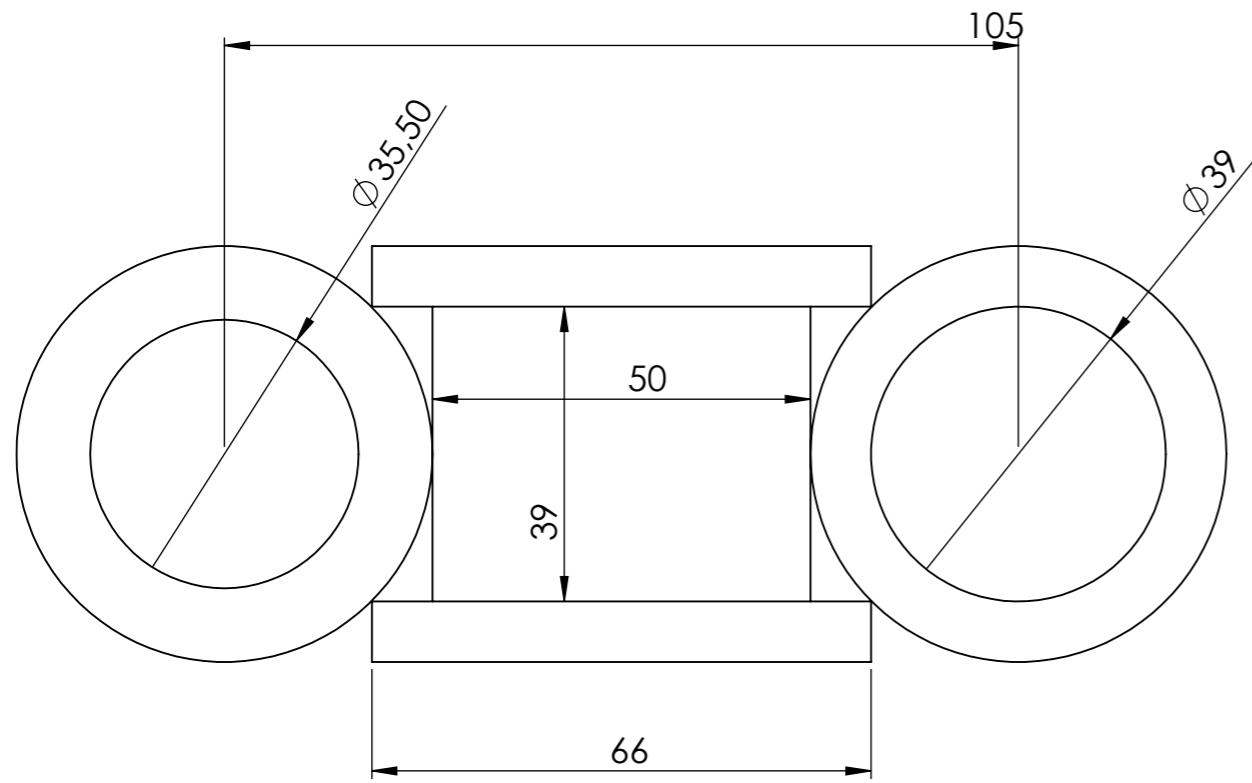

N°	Désignation	Longueur	Gabarit seul/Quantité
Moyeux diam. 35	Moyeu diam int 35 L 50		1
Moyeux diam.39	Moyeu Diam int 39 L50		1
GabE21.1	Fer plat 50 x 10	39	1
GabE21.2	Fer plat 40 x 8	66	2

Version	1.0	Qté	1	
Date	26/10/2015			
Outil	Néo Bucher			
Pièce	Gabarit fusée gauche et droite E2 et E3			

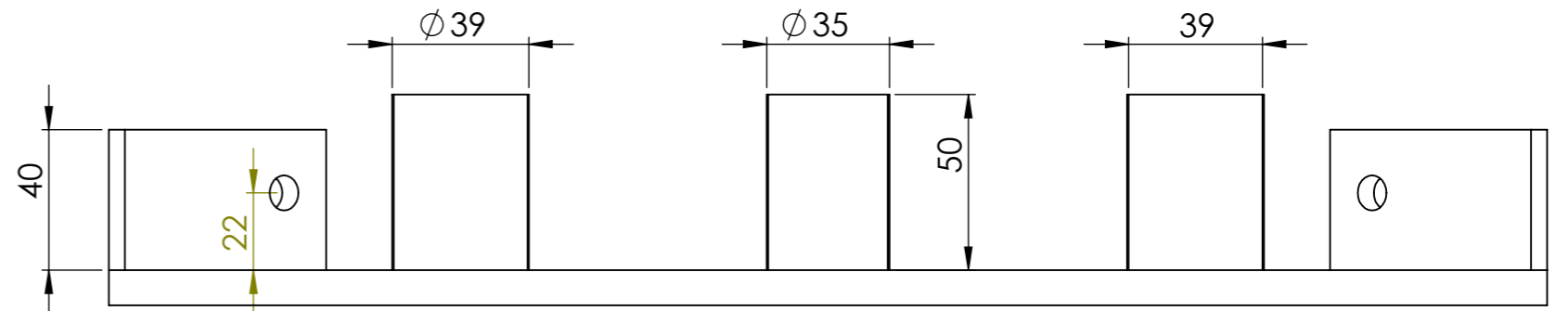
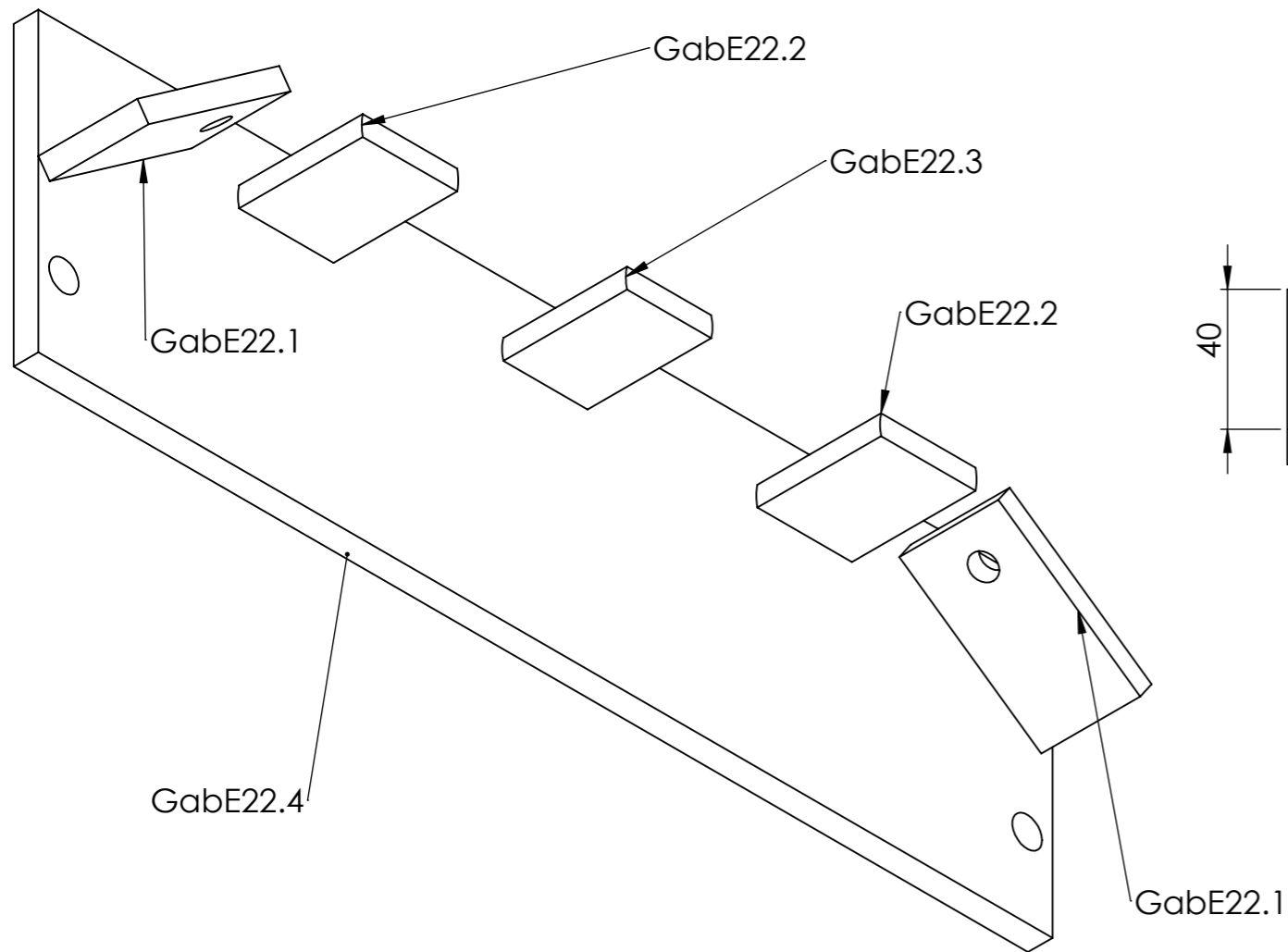
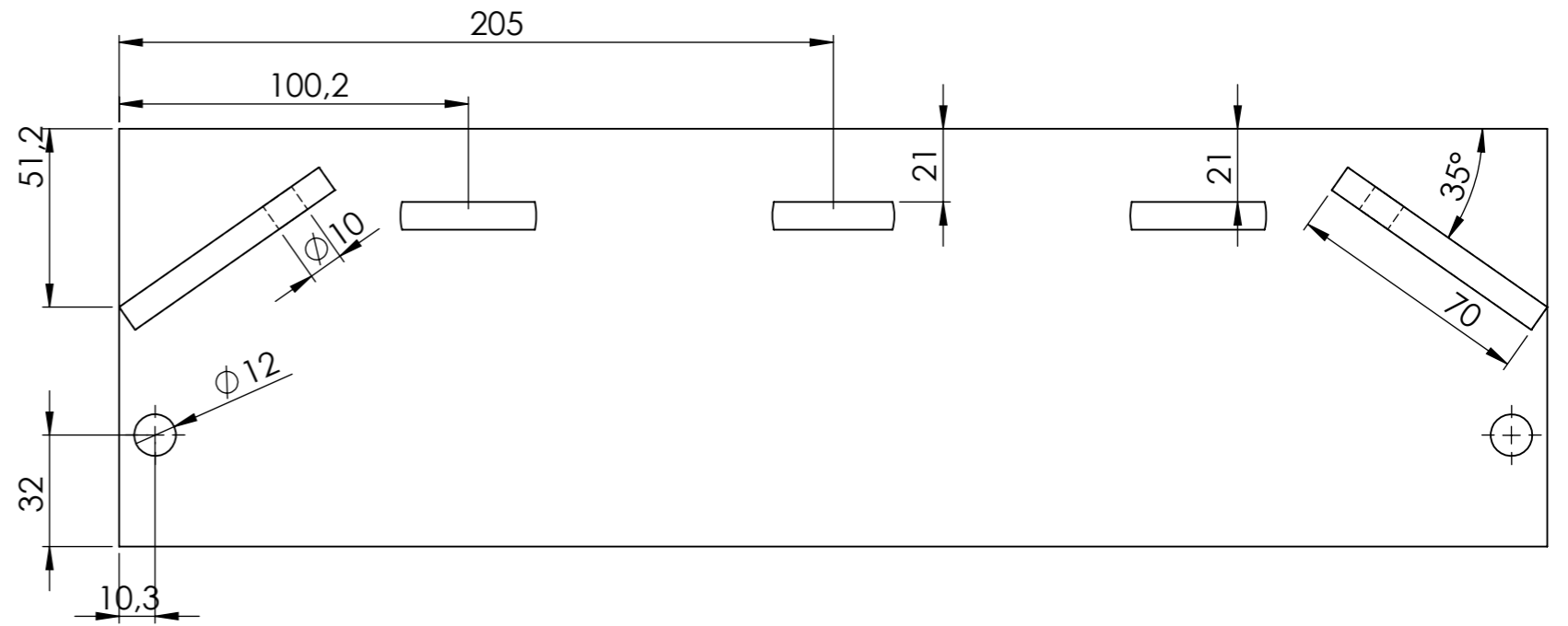
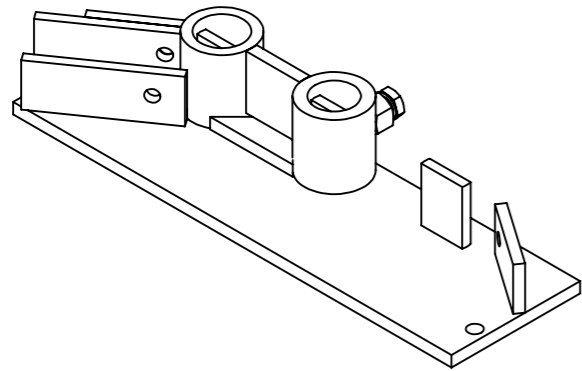
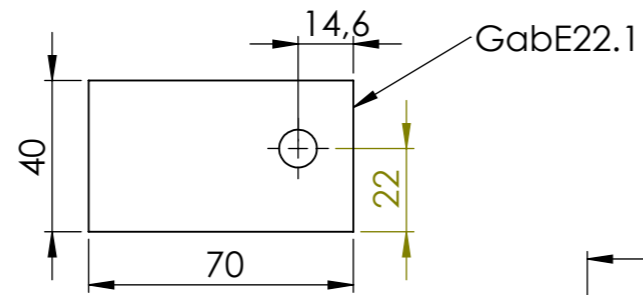

N°	Désignation	Longueur	Gabarit seul/Quantité
GabE22.1	Fer plat 40 x 8	70	2
GabE22.2	Fer plat 40 x 8	50	2
GabE22.3	Fer plat 40 x 8	50	1
GabE22.4	Fer plat 120 x 10	410	1

Version	1.0	Qté	1	
Date	26/10/2015			
Outil	Néo Bucher			
Pièce	Gabarit roue E8			

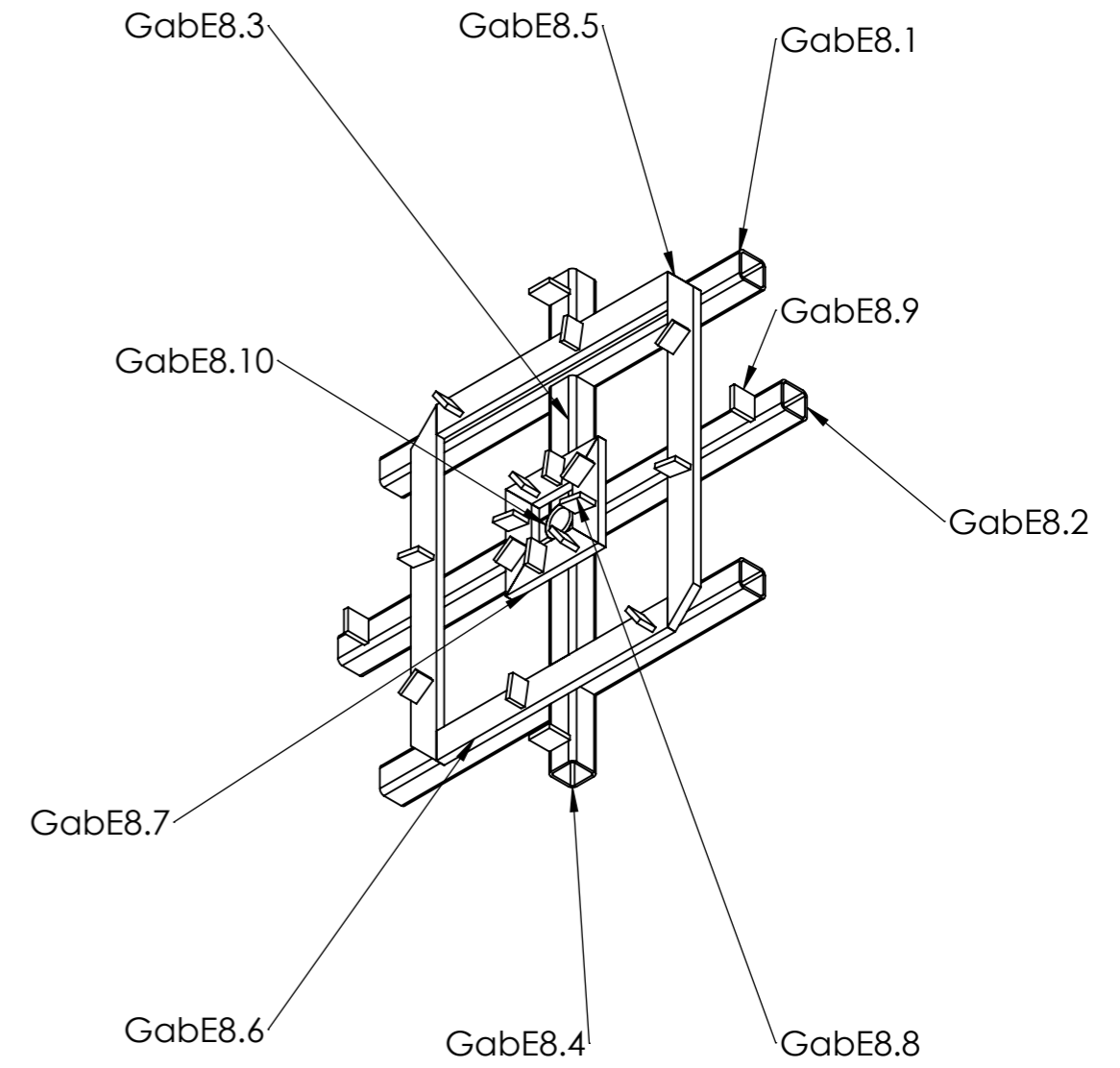
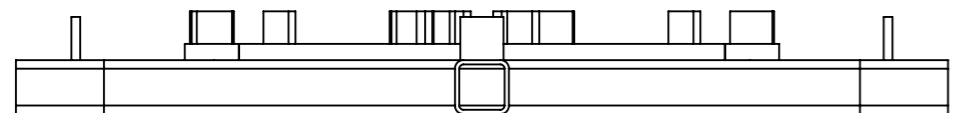
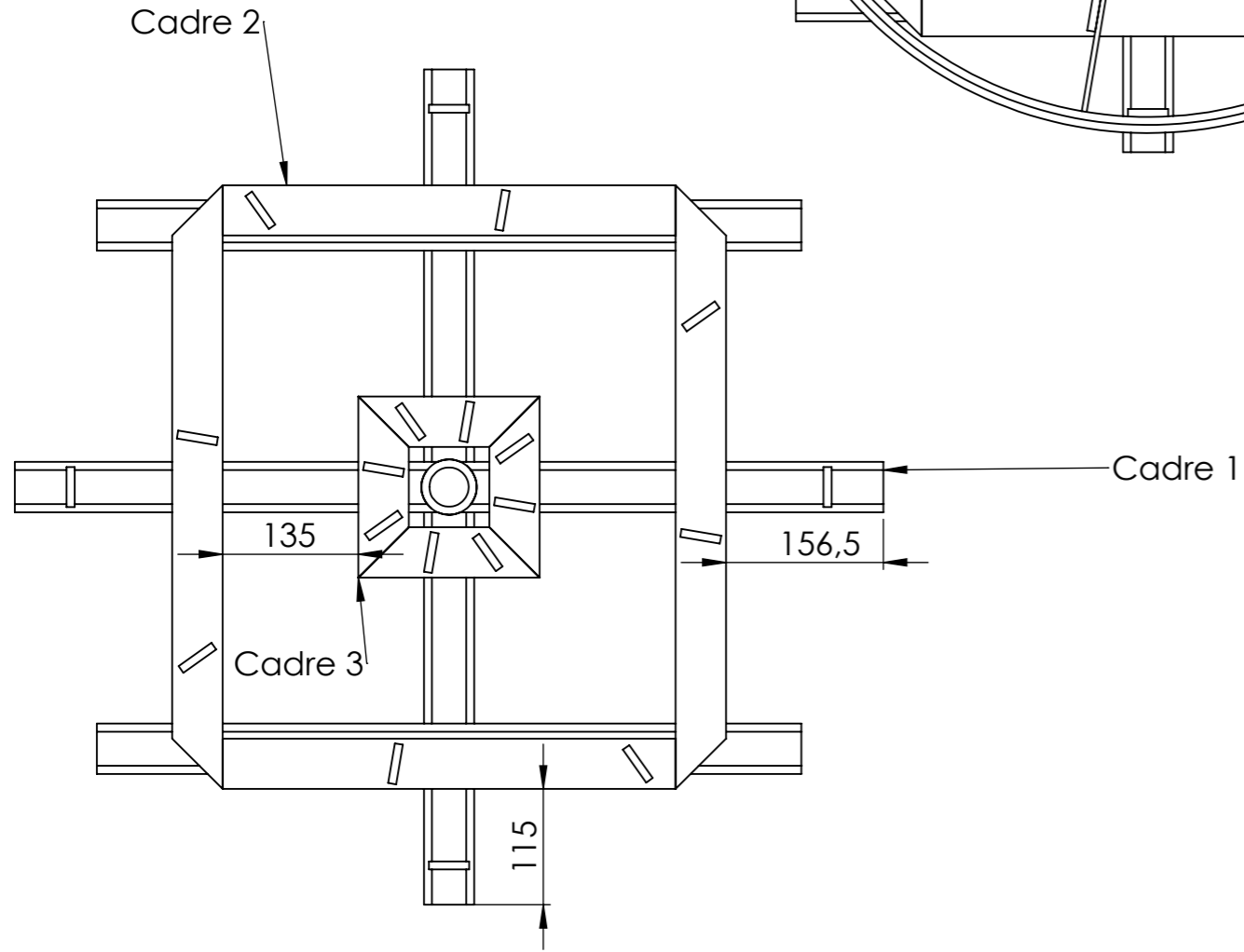
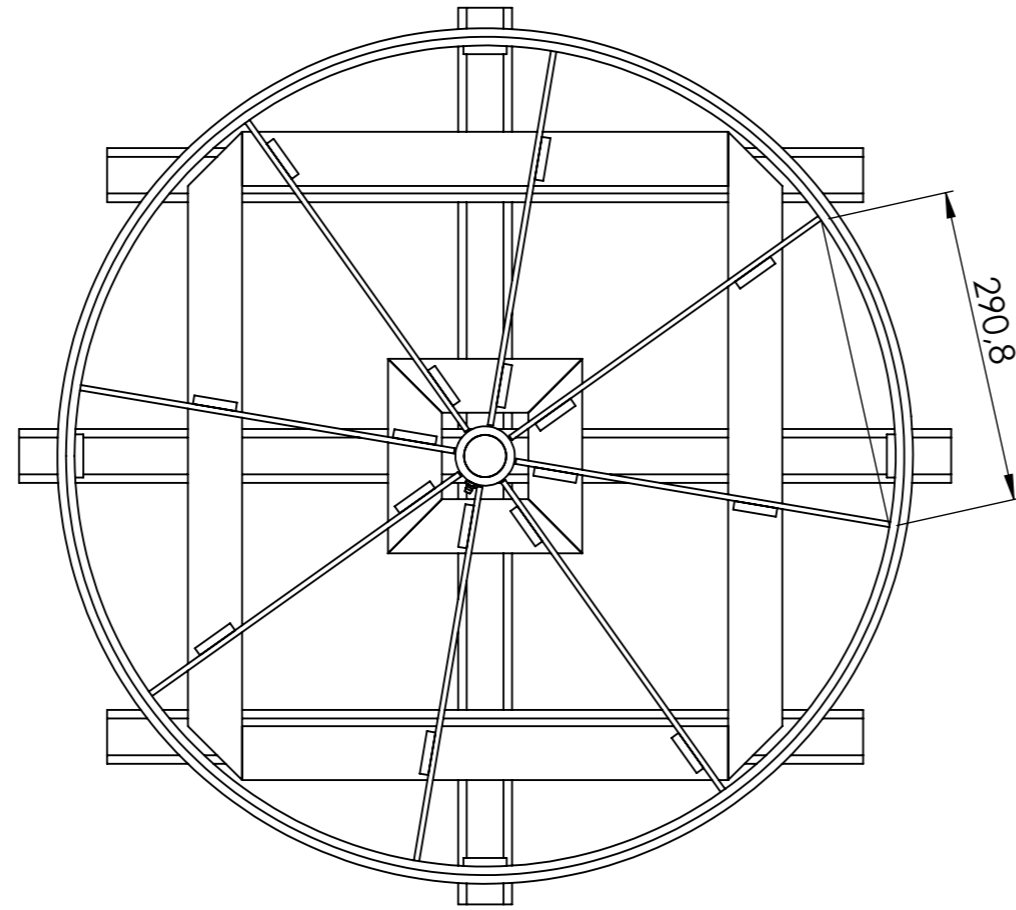

N°	Désignation	Longueur	gabarit seul/Quantité
GabE8.1	tube carré 50 x 4	700	2
GabE8.2	tube carré 50 x 4	420	2
GabE8.3	tube carré 50 x 4	210	2
GabE8.4	tube carré 50 x 4	130	2
GabE8.10			1
GabE8.5	Fer plat 50 x 15	600	2
GabE8.6	Fer plat 50 x 15	450	2
GabE8.7	Fer plat 50 x 15	180	4
GabE8.8	Fer plat 40 x 8	30	16
GabE8.9	Fer plat 40 x 8	40	4

Version	1.0	Qté	1	
Date	26/10/2015			
Outil	Néo Bucher			
Pièce	Gabarit roue E8, cadre 1			



Cadre 1

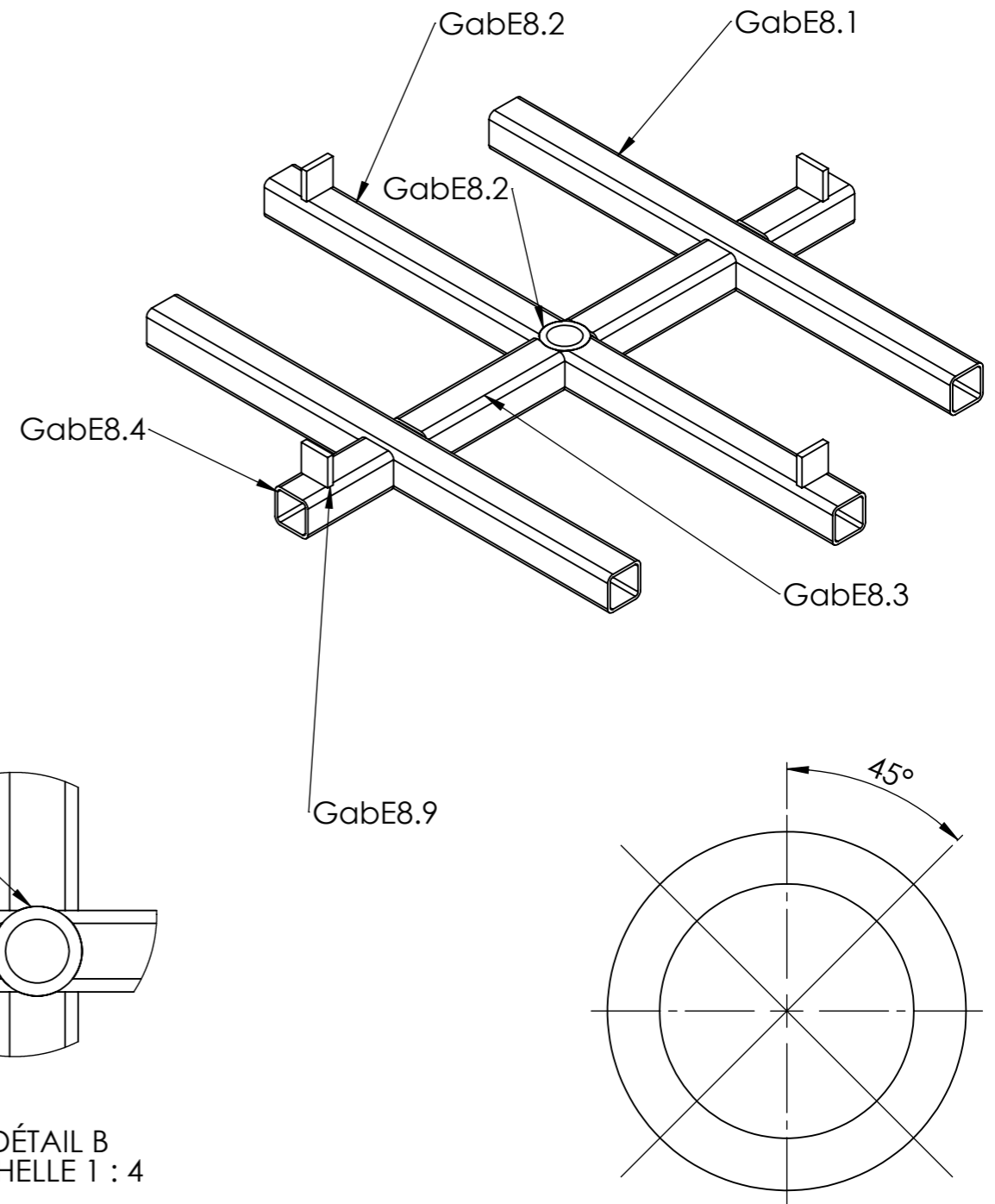
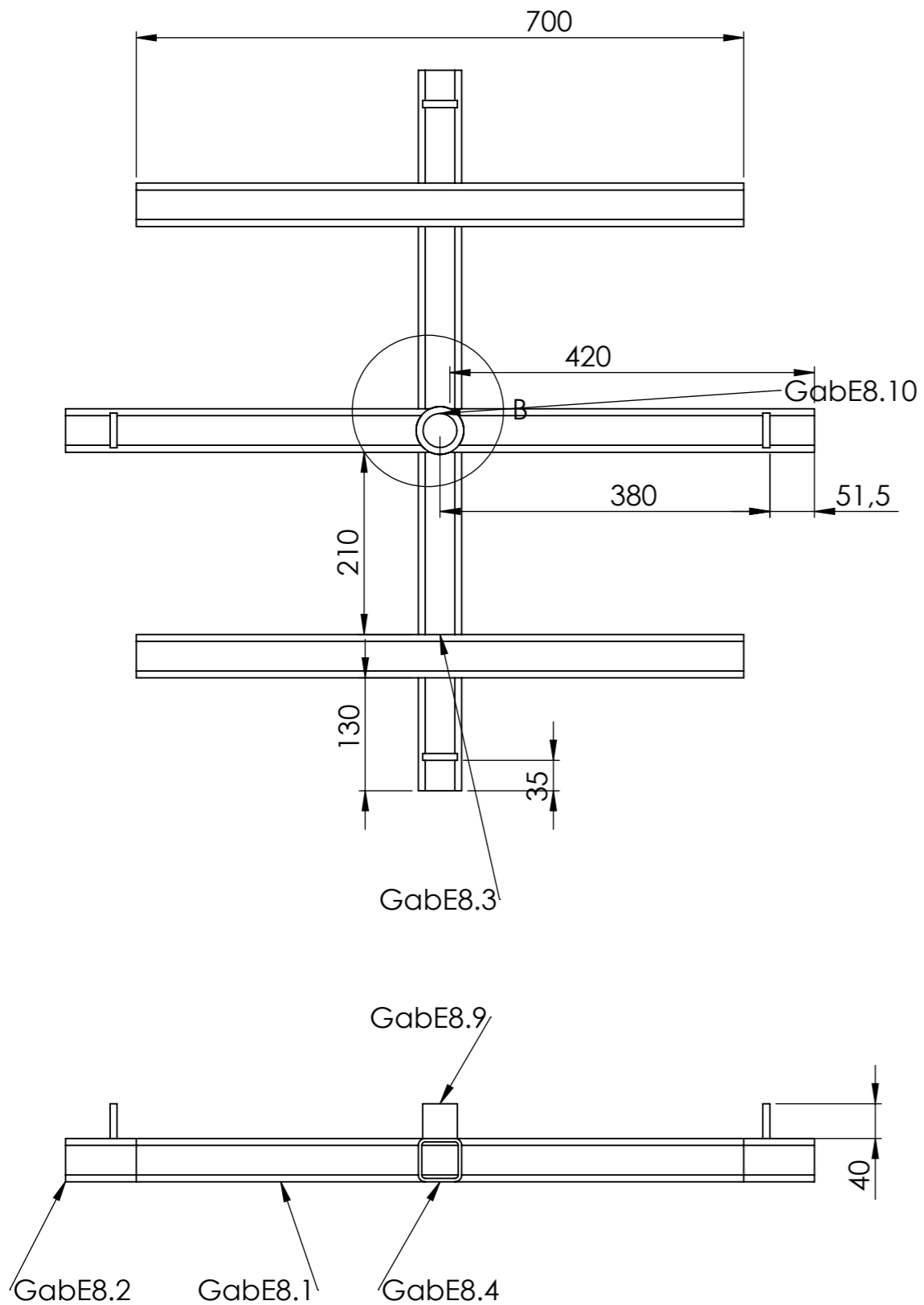

DÉTAIL B
ECHELLE 1 : 4

N°	Désignation	Longueur	cadre1/Quantité
GabE8.1	tube carré 50 x 4	700	2
GabE8.2	tube carré 50 x 4	420	2
GabE8.3	tube carré 50 x 4	210	2
GabE8.4	tube carré 50 x 4	130	2
GabE8.10			1
GabE8.9	Fer plat 40 x 8	40	4

Version	1.0	Qté	1	
Date	26/10/2015			
Outil	Néo Bucher			
Pièce	Gabarit roue E8, cadres 2 et 3			



Cadre 2

2 x :

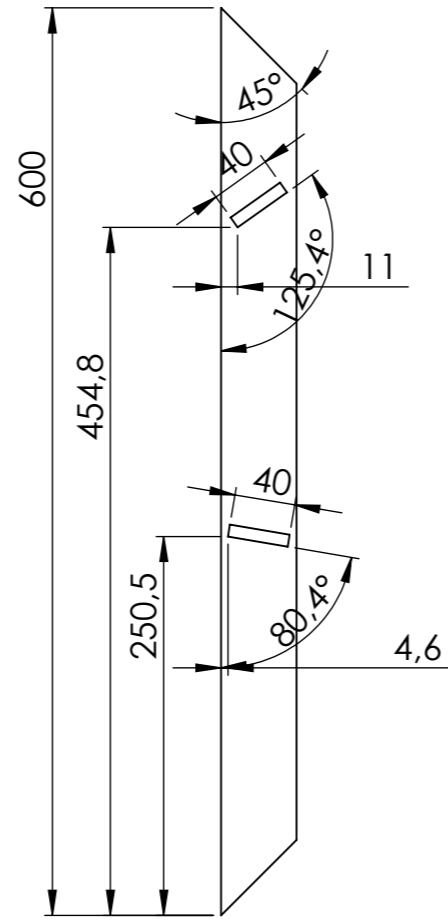
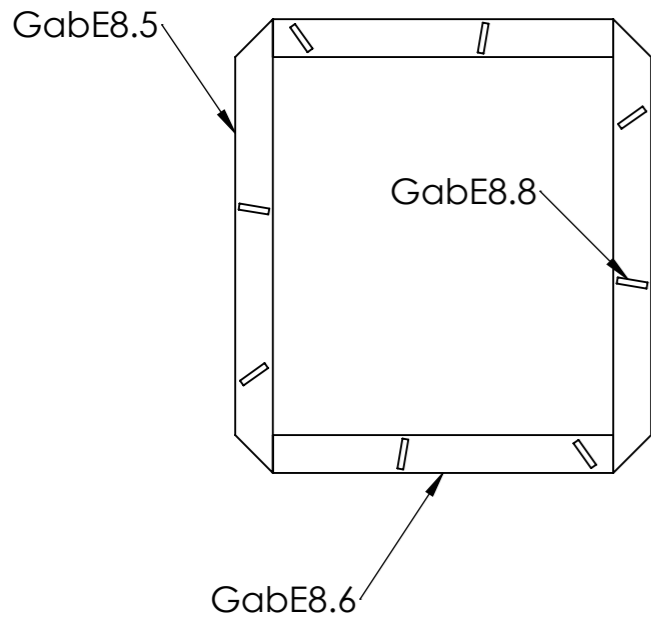

2 x :

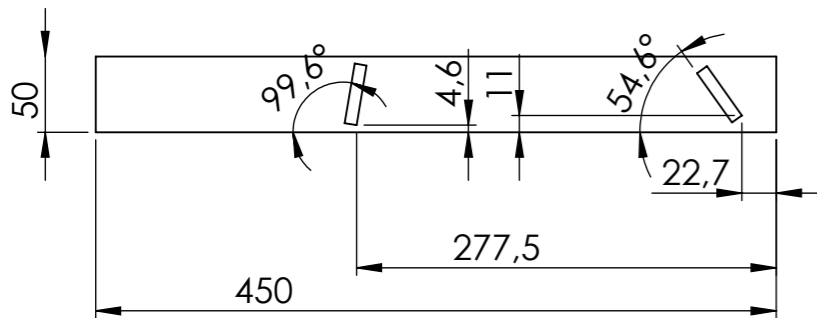

N°	Désignation	Longueur	cadre2/Quantité
GabE8.5	Fer plat 50 x 15	600	2
GabE8.6	Fer plat 50 x 15	450	2
GabE8.8	Fer plat 40 x 8	30	8

Cadre 3

N°	Désignation	Longueur	cadre3/Quantité
GabE8.7	Fer plat 50 x 15	180	4
GabE8.8	Fer plat 40 x 8	30	8

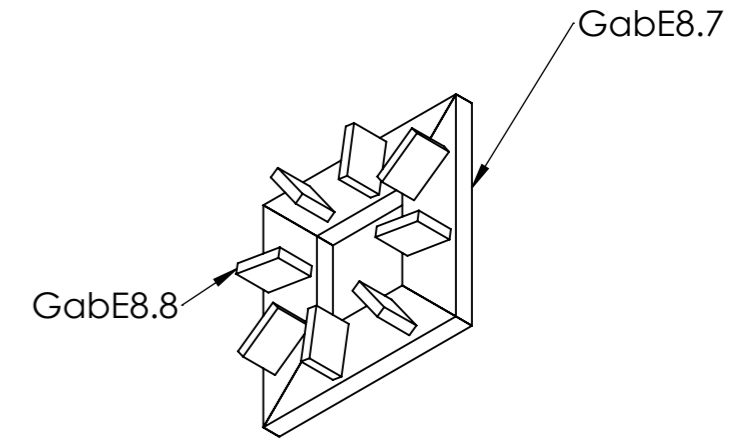
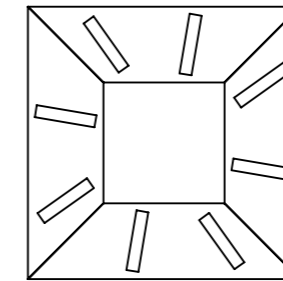

4 x :

