

Outil	Chariot à roulette				
Date	01/09/2020	Version	1.0		page n° 1 / 5
Feuille	Nomenclature générale				

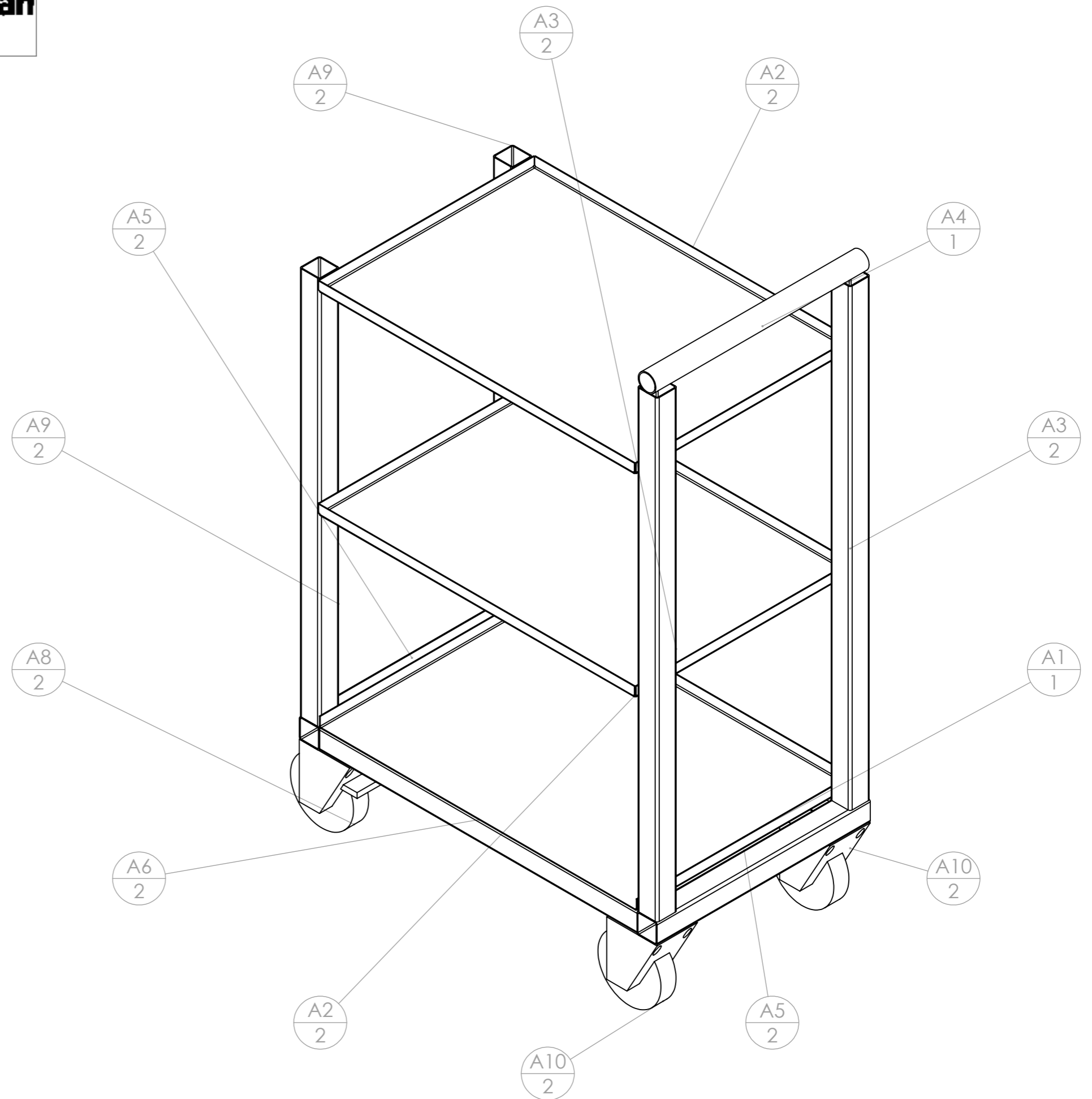

repère	Désignation	LONGUEUR	Quantité
A1	A1 plateau bas chariot		1
A2	A2 plateau haut chariot		2
A3	tube carré 40 x 2	900	2
A5	tube carré 40 x 2	423	2
A6	tube carré 40 x 2	630	2
A4	tube rond 35 x 2	423	1
A7	tube carré 40 x 2	343	2
A8	Roue pivotante freinée 125mm		2
A9	tube carré 40 x 2	770	2
A10	Roue pivotante 125mm		2

Outil	Chariot à roulette			L'atelier paysan	
Date	01/09/2020	Version	1.0		page n° 2 / 5
Feuille	Encombrement				

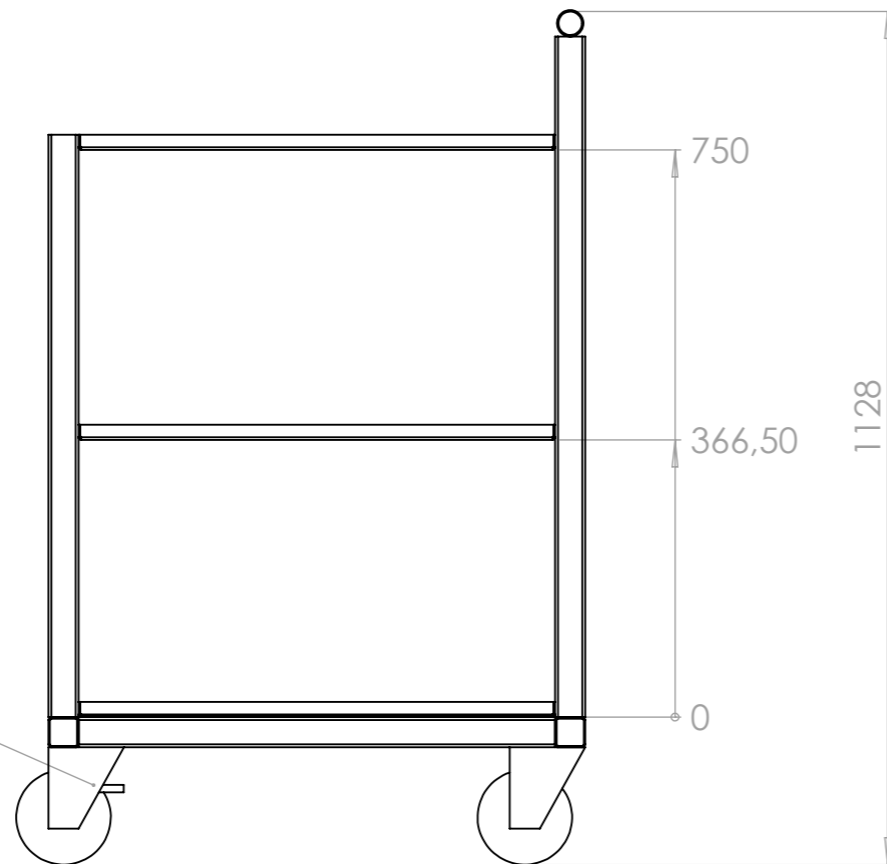
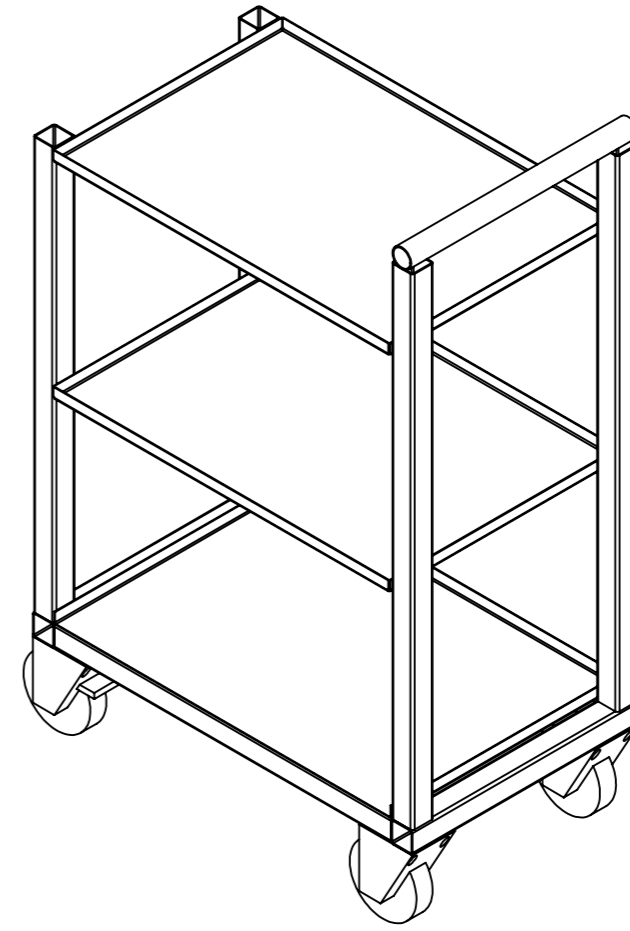
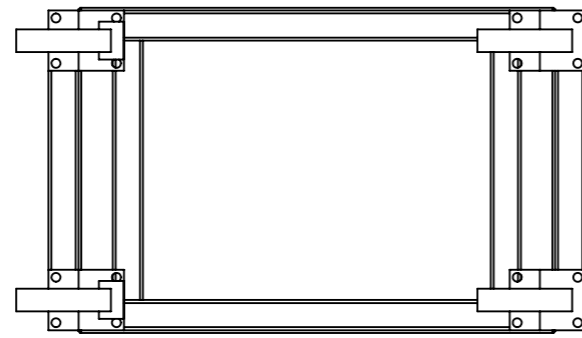

Les plaques des roulettes
sont soudées

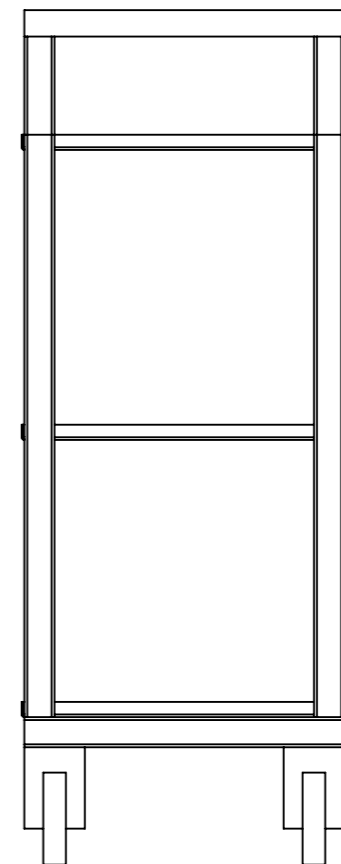
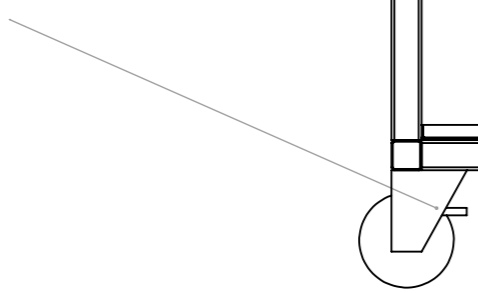

Outil	Chariot à roulette				
Date	01/09/2020	Version	1.0		page n° 3 / 5
Feuille	A1				



A1
1

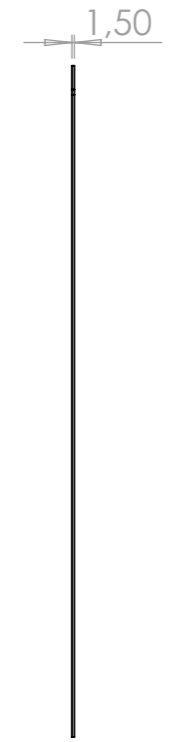
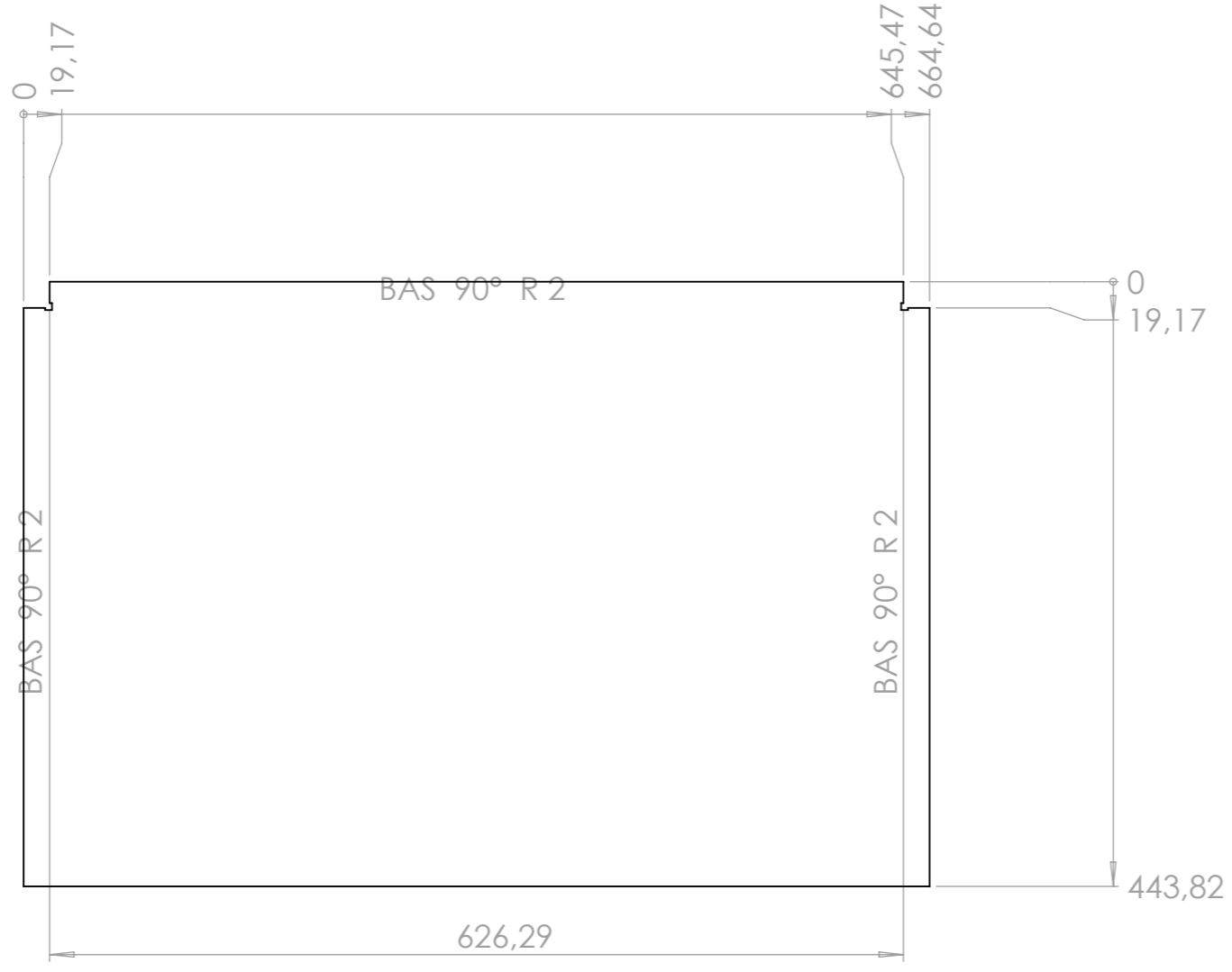
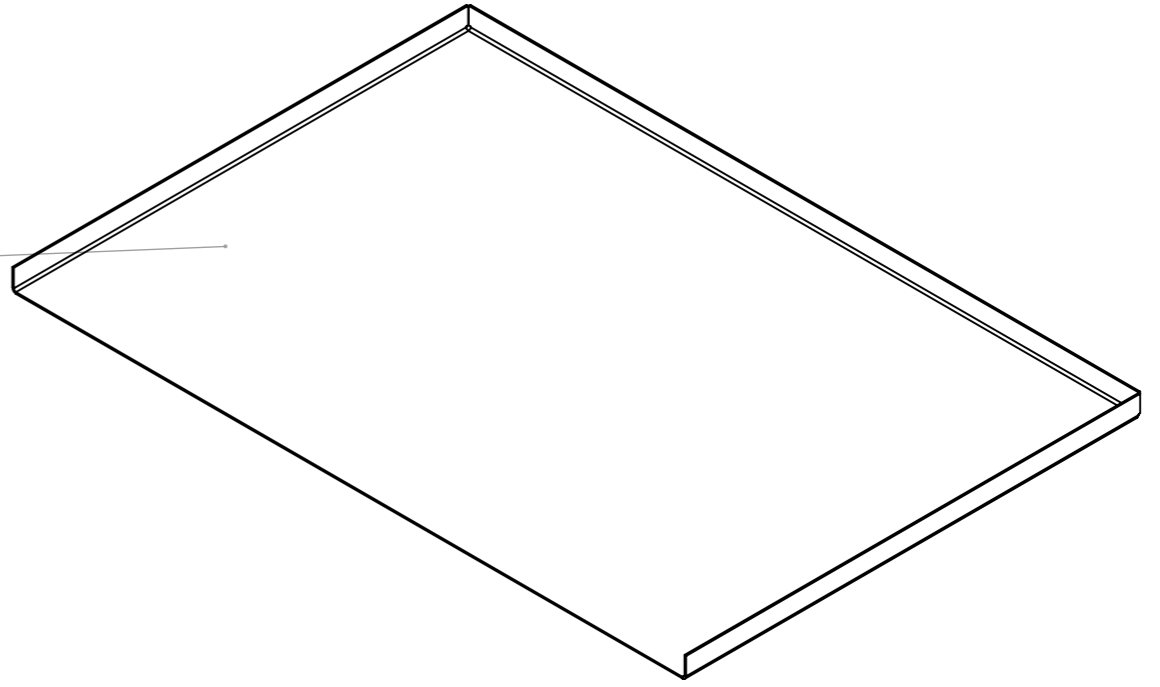

Outil	Chariot à roulette				
Date	01/09/2020	Version	1.0		page n° 4 / 5
Feuille	A2				

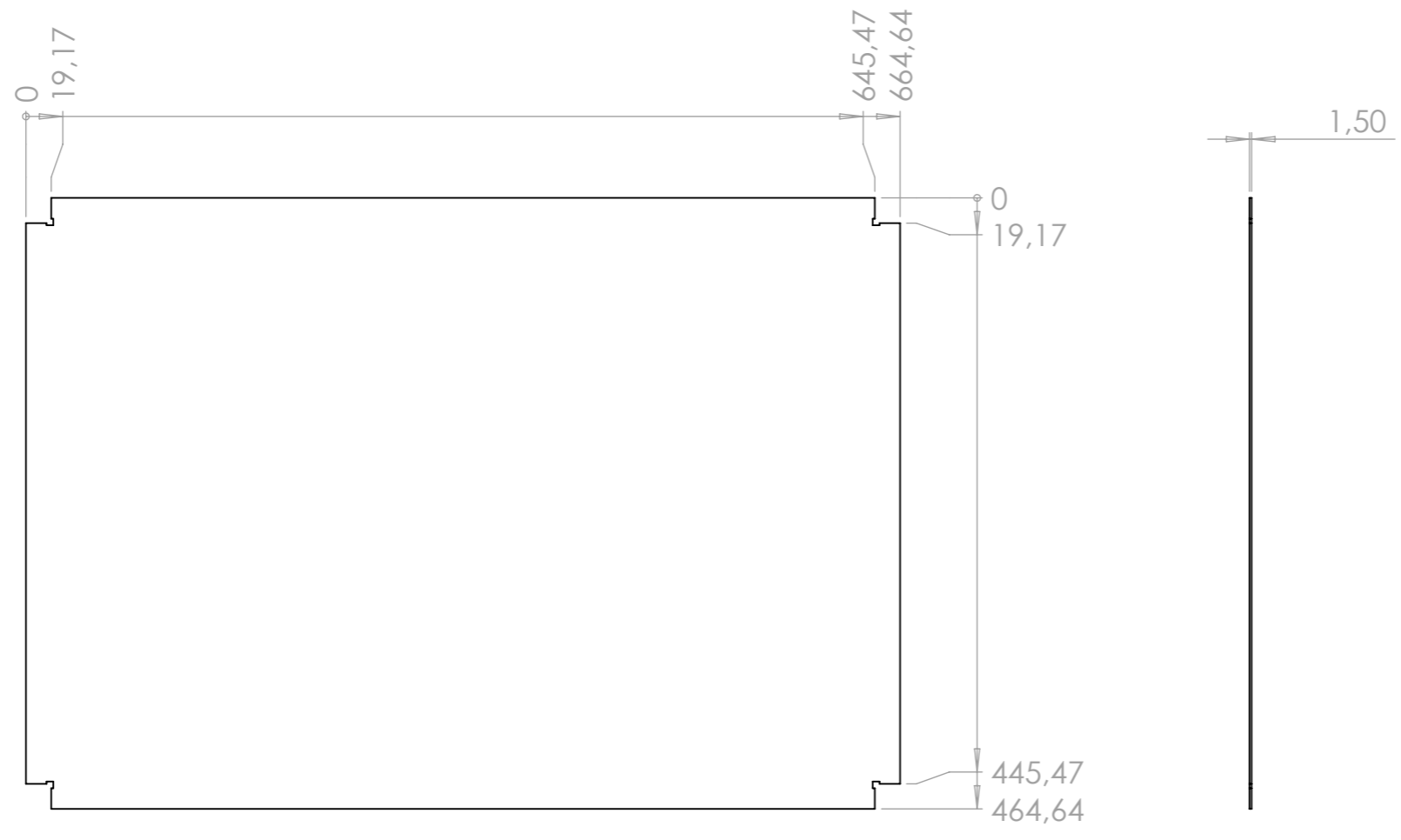
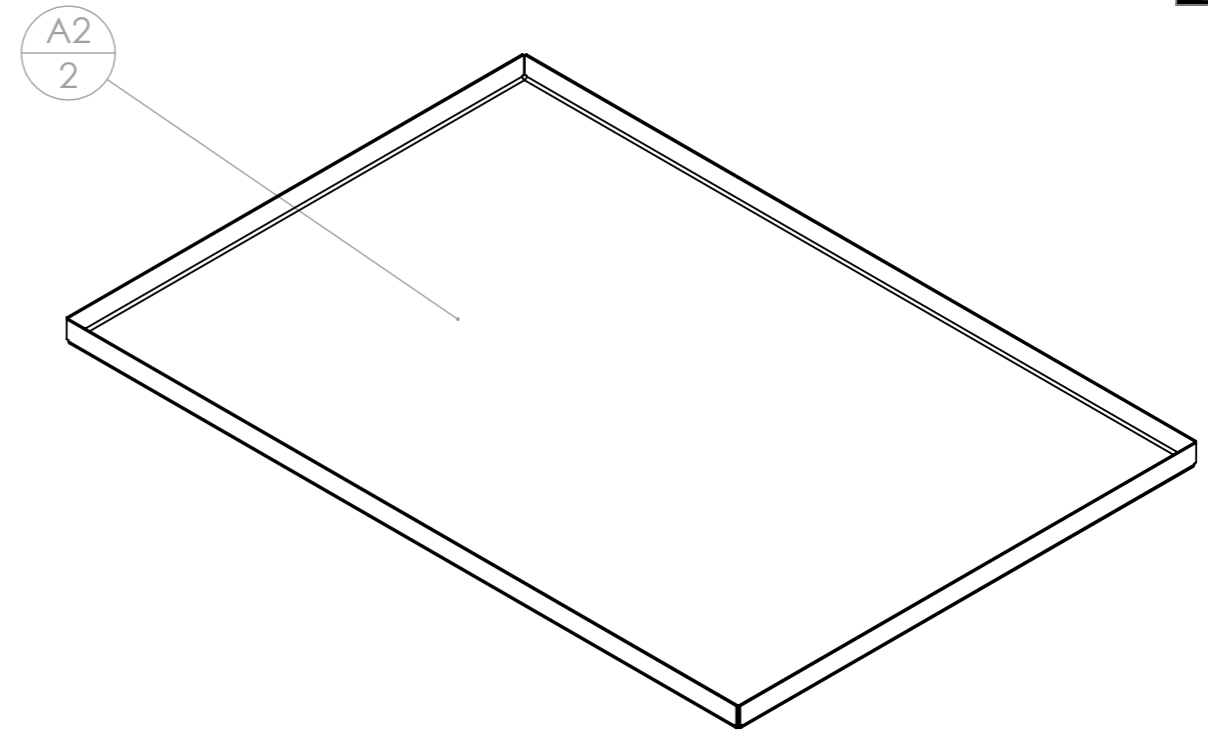

Outil	Chariot à roulette				
Date	01/09/2020	Version	1.0		page n° 5 / 5
Feuille	Chassis				

