

Pièce	Désignation	Qté
S	chassis bas large	1
V	barre porte dent	1
X	support barre porte cuillère	2
Y	barre porte cuillère	1
Z	bras support module bas	2
D	Bride viticole	2
Bride en U pour bâti de 80	Bride en U pour bâti de 80	4
Écrou	Écrou M16 autofreiné	16
Vis Hexagonale	Vis hexagonale M16 x 35	6
Vis Hexagonale	Vis hexagonale M16 x 50	6
Broche 1 - 16 L100	Broche pliée Ø16 - L100	2
Goupille épingle d'axe, 15x70 Ø4	Goupille épingle d'axe 15x70 Ø4	2

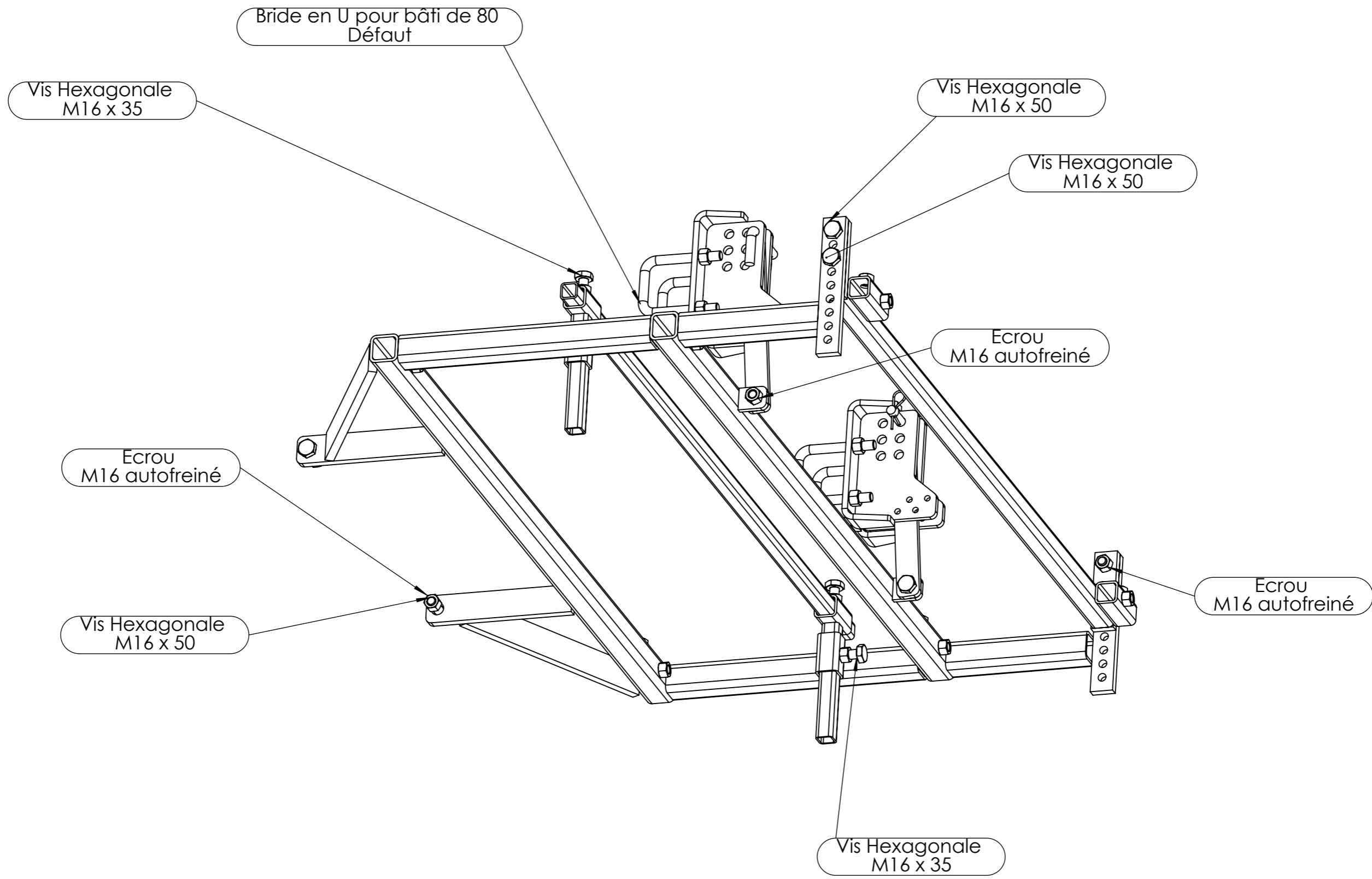

Outil	<b>Cadre ST large</b>			<b>L'atelier paysan</b>	
Date	30/07/2021	Version	4.0		page n° 3 / 13
Feuille	<b>Vue générale(2)</b>				

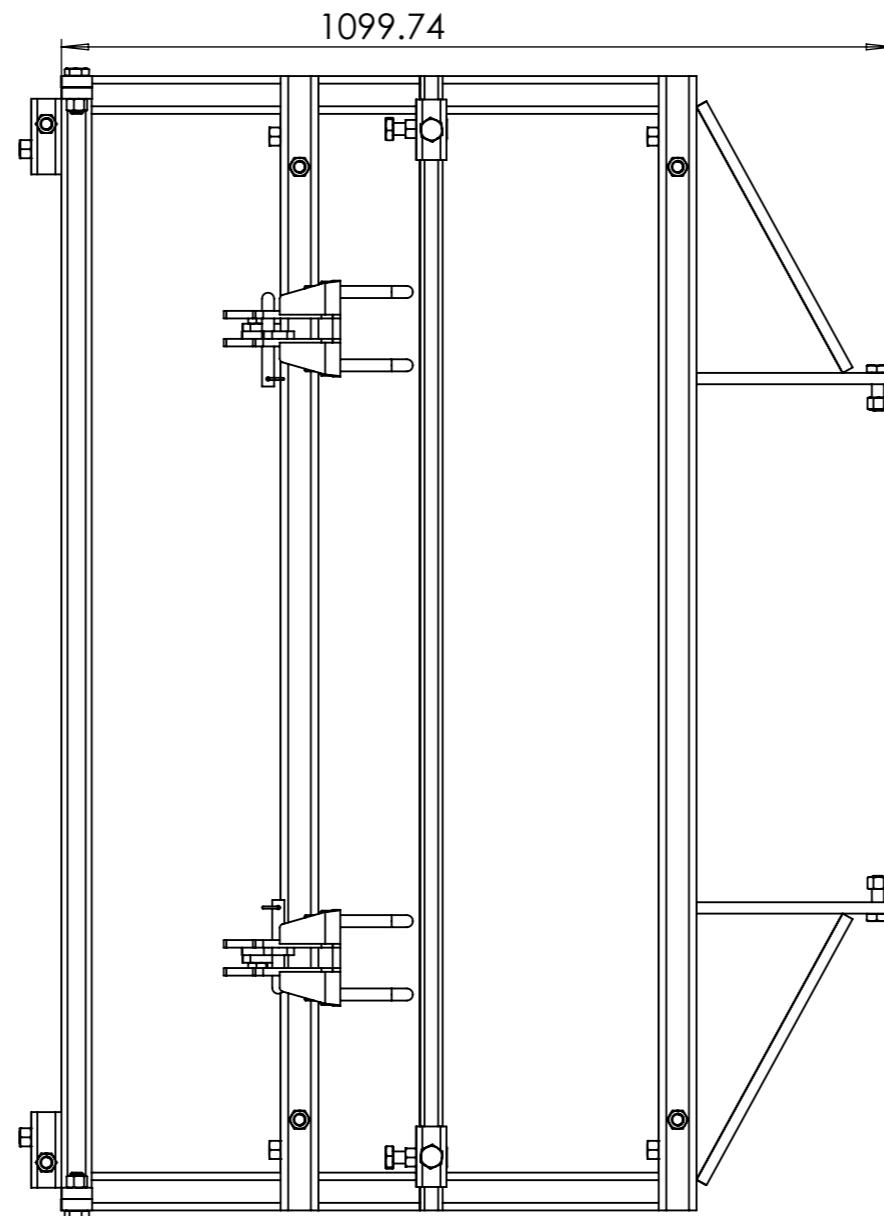

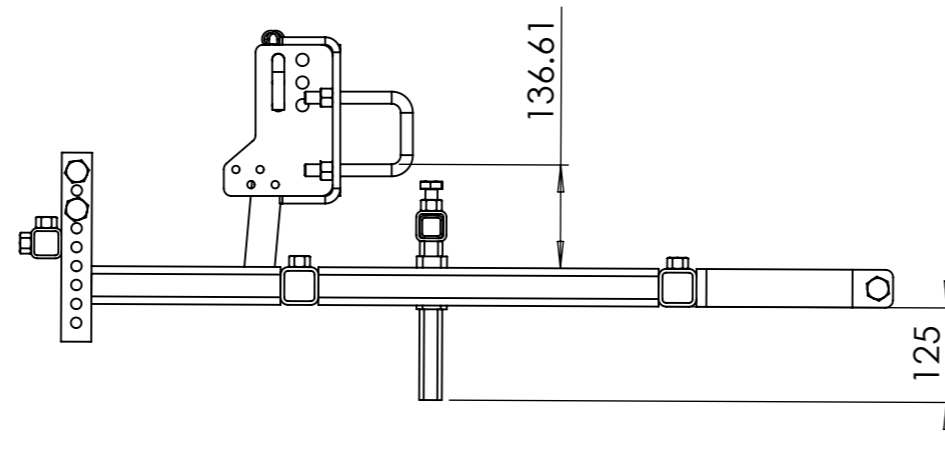
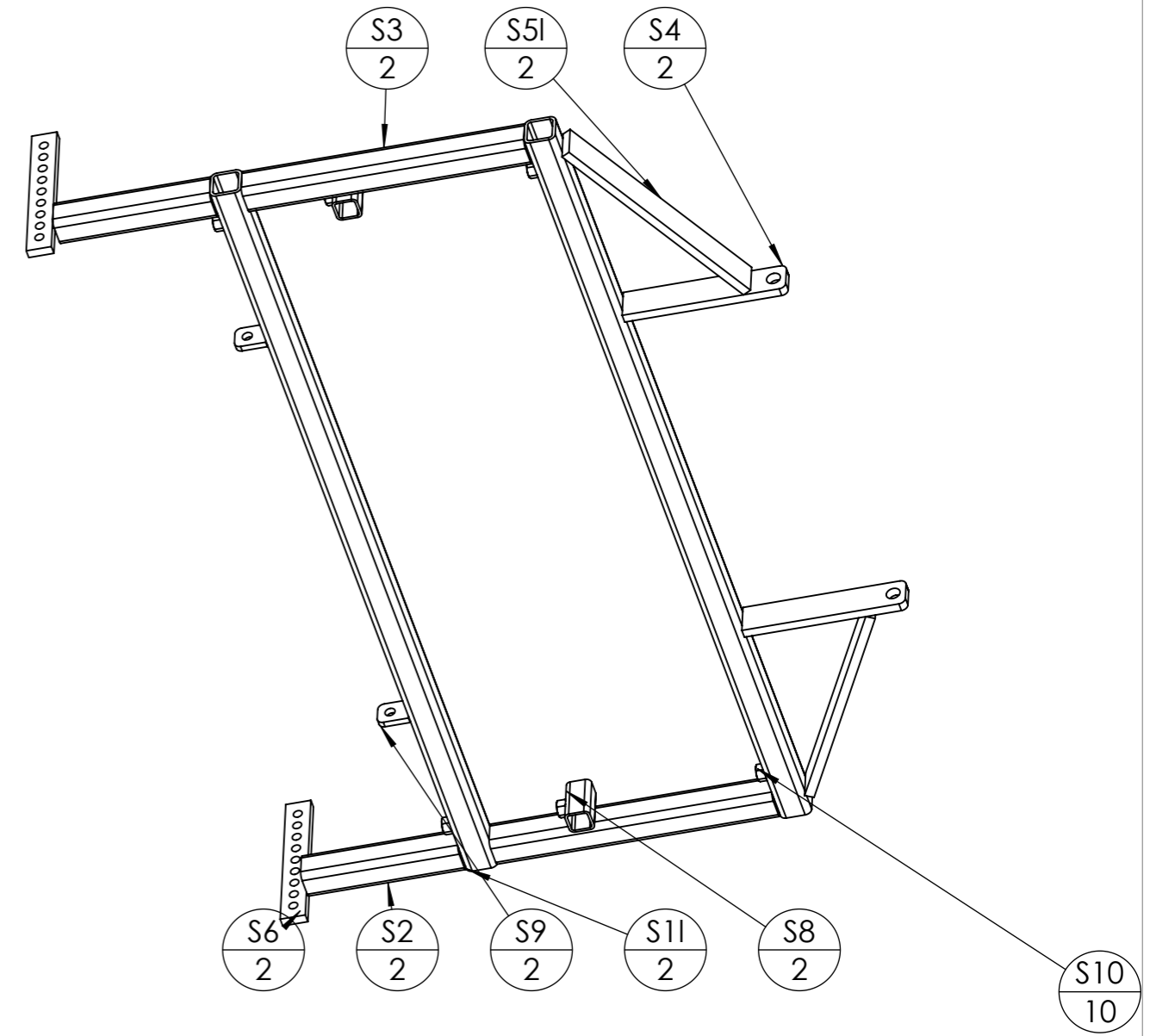
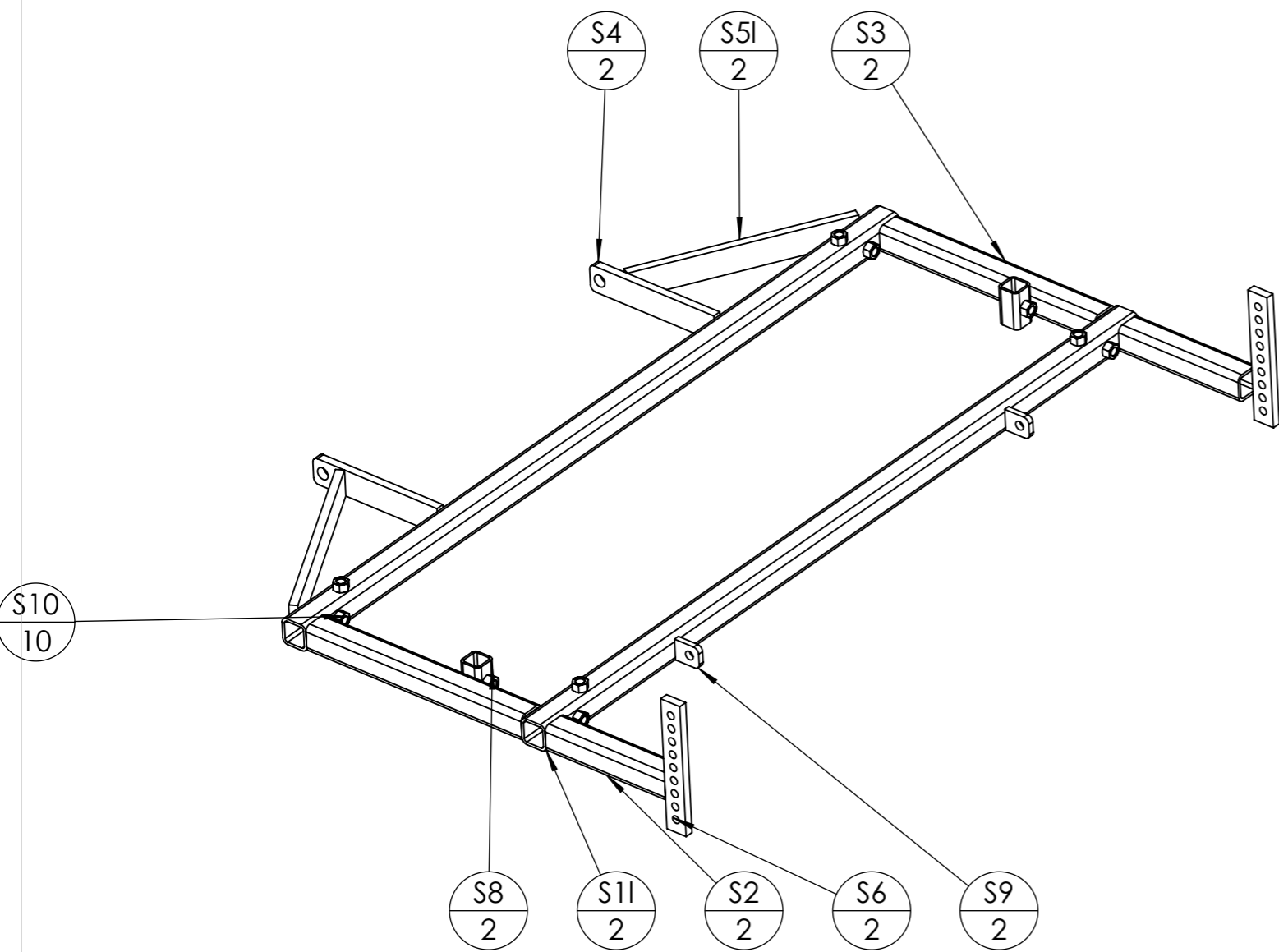

ID	Description	ANGLE1	ANGLE2	p	Longueur	Qté
S11	tube carré 50 x 5	0.00	0.00	17	1500	2
S2	tube carré 50 x 5	0.00	0.00		250	2
S3	tube carré 50 x 5	0.00	0.00		450	2
S4	fer plat 50 x 15	0.00	0.00	22	260	2
S5l	fer plat 50 x 15	0.00	0.00		401.4653	2
S6	Fer plat 40 x 15	0.00	0.00	14	250	2
S8	tube carré 40 x 4	0.00	0.00	17	70	2
S9	Fer plat 40 x 10	0.00	0.00	16	50	2
S10	Ecrou M16 brut					10

Outil	<b>Cadre ST large</b>				
Date	30/07/2021	Version	4.0		page n° 5 / 13
Feuille	<b>S large position</b>				

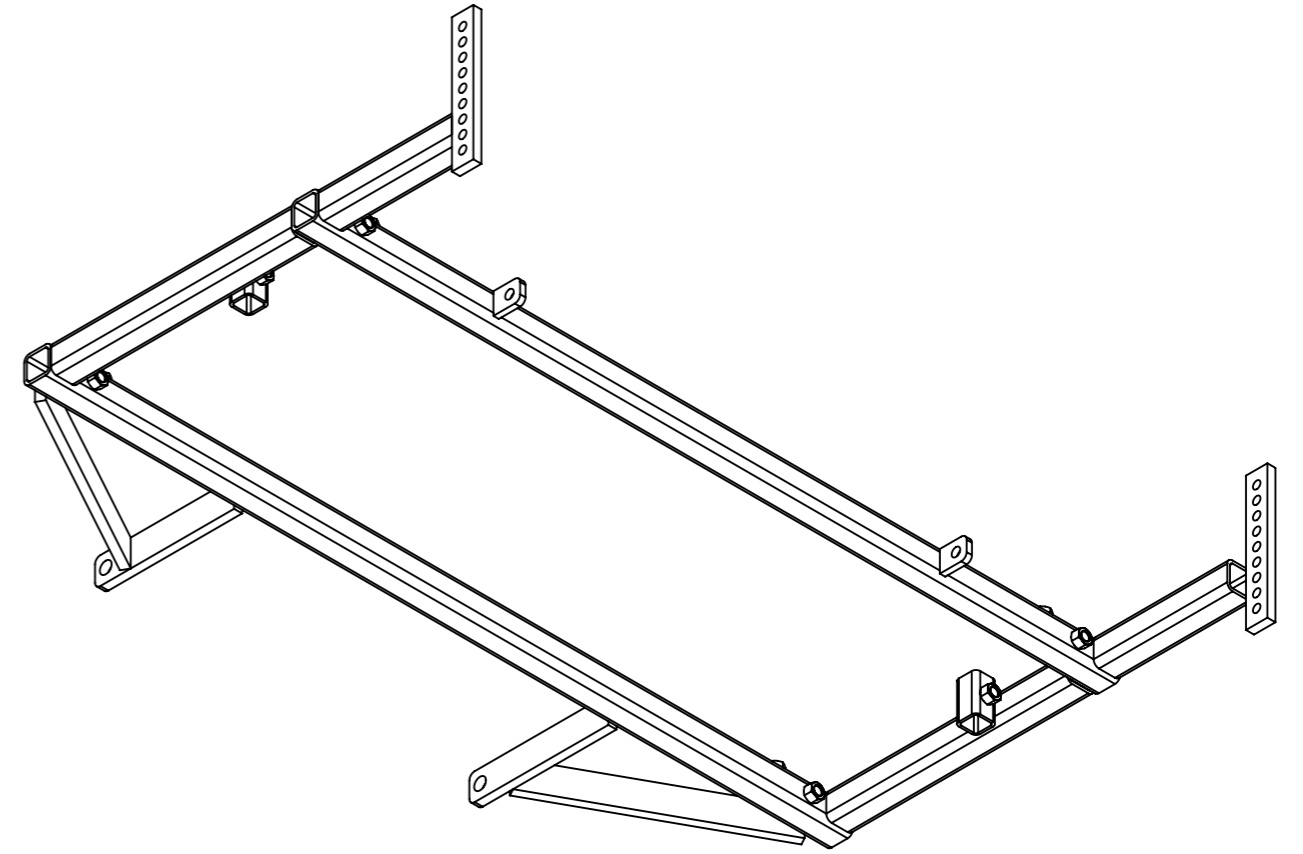
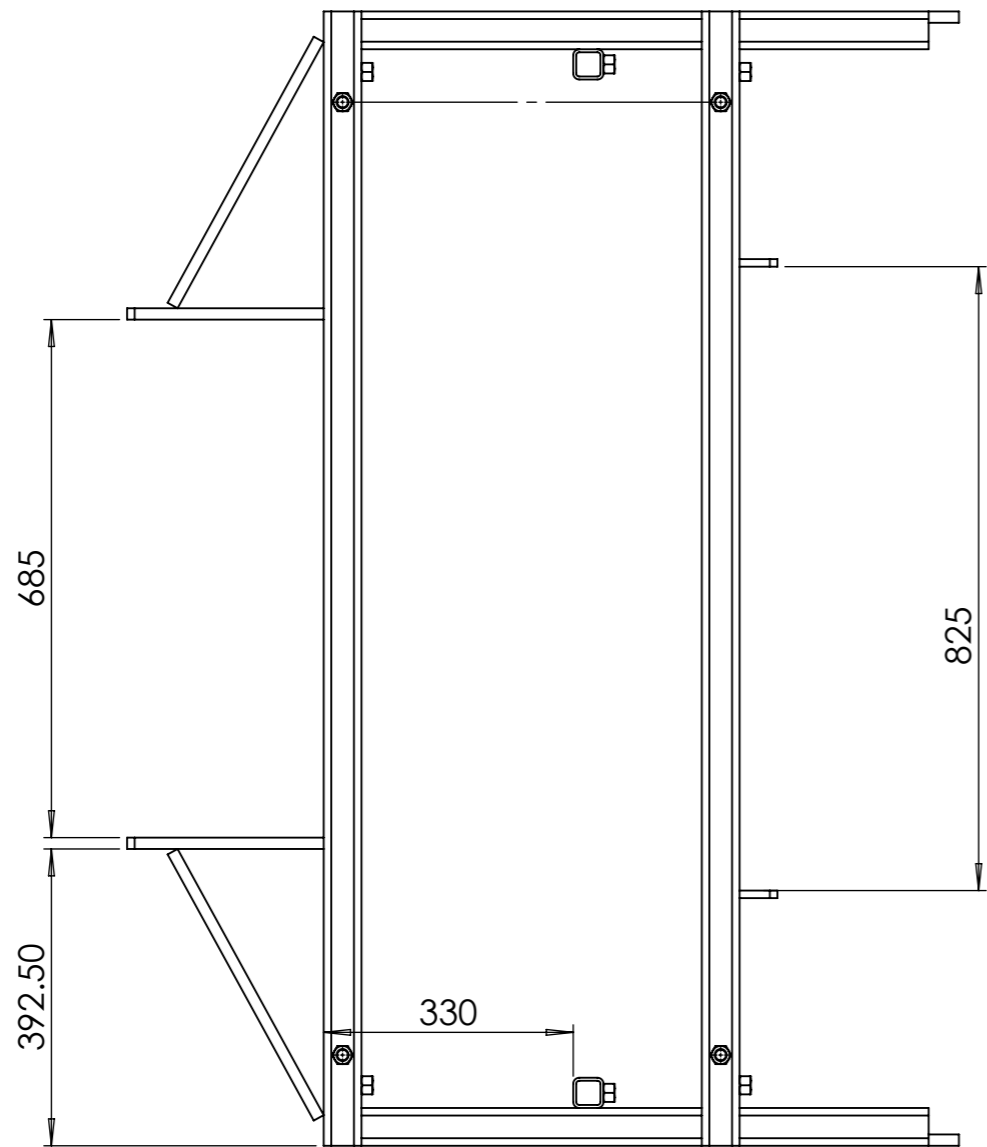
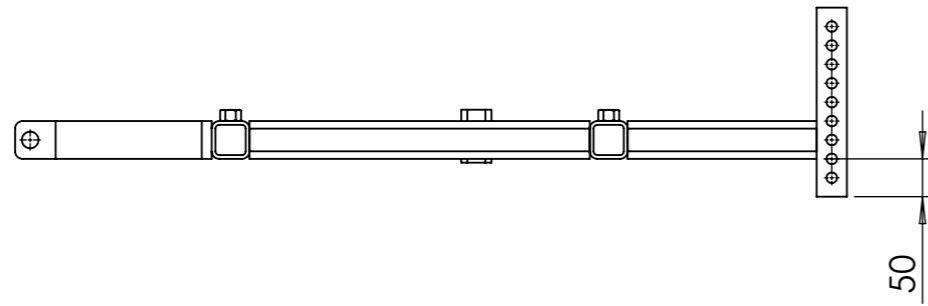

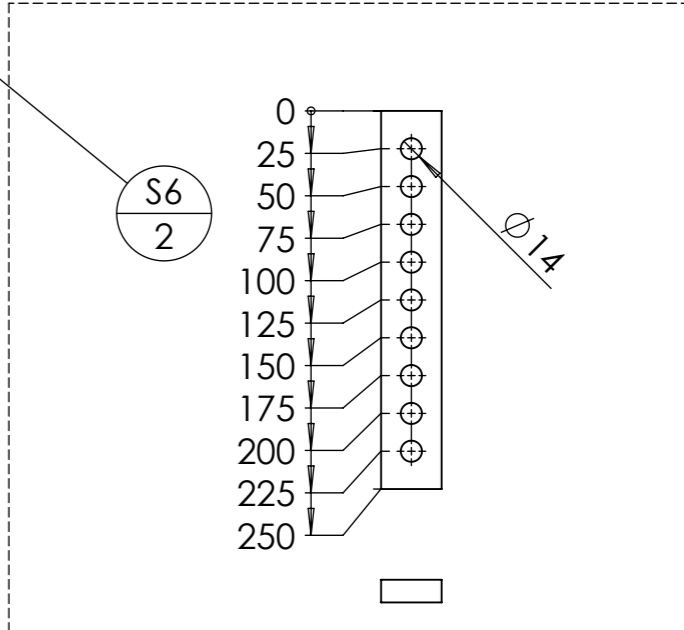
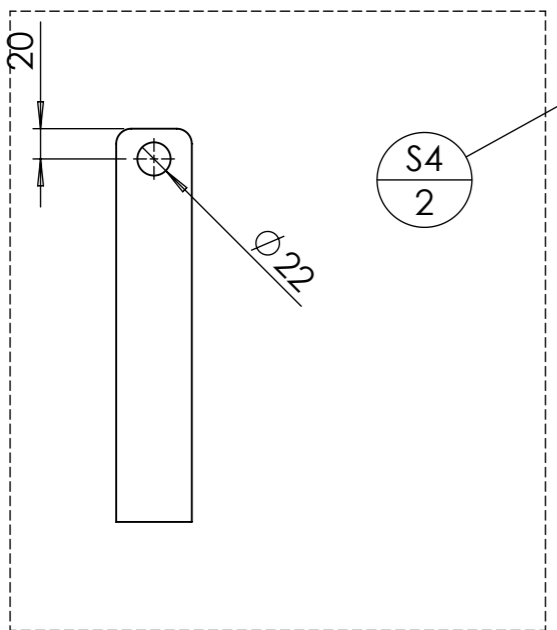
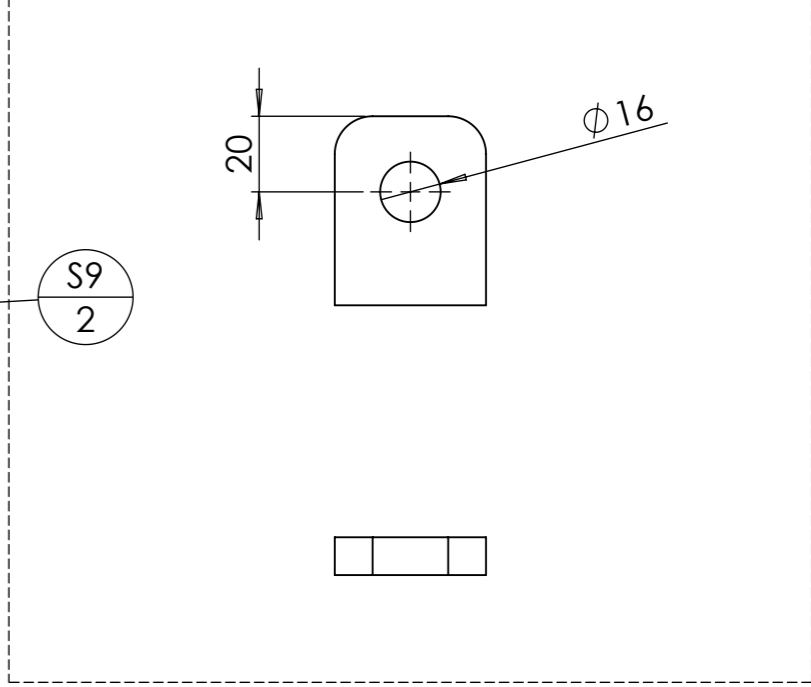
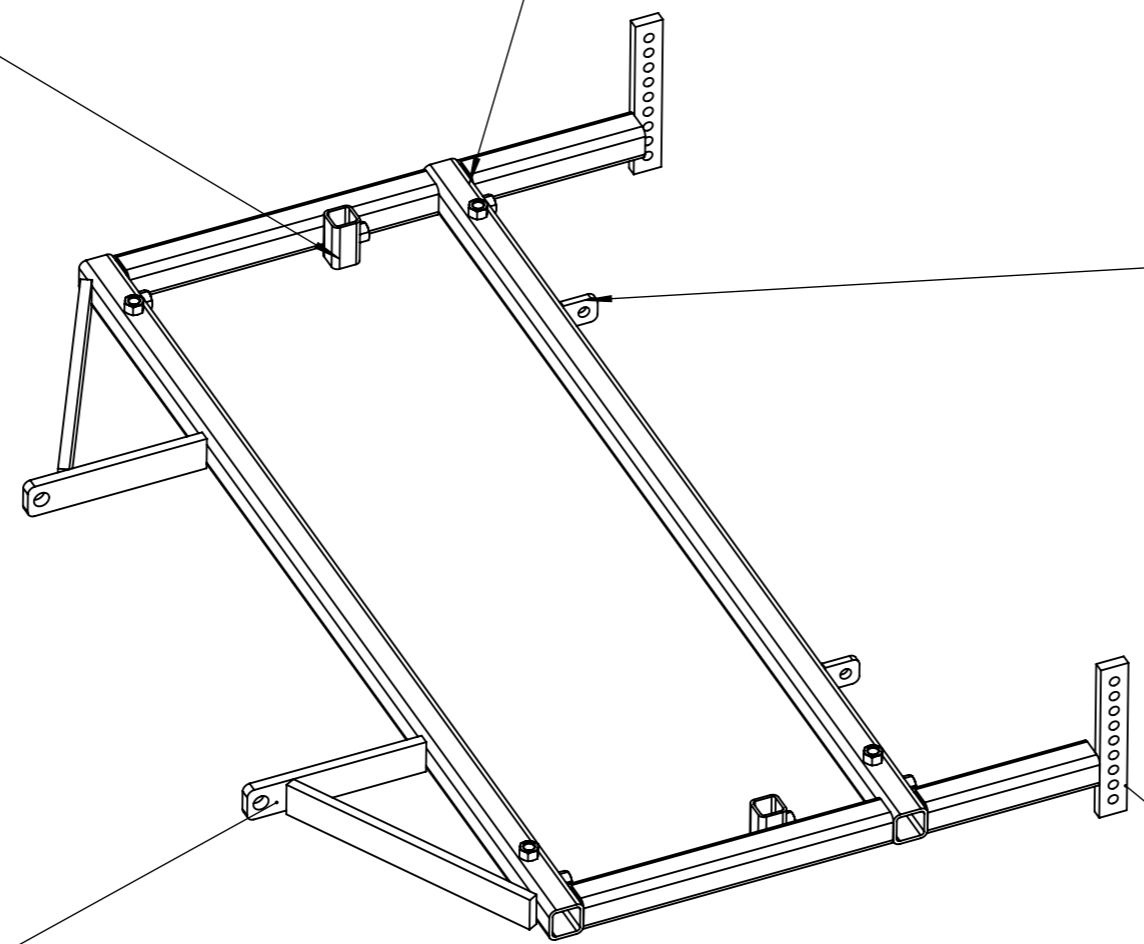
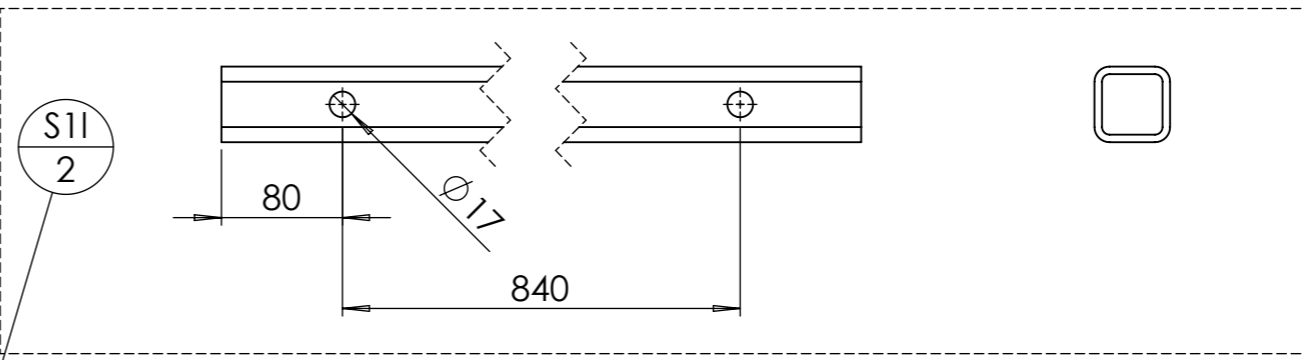
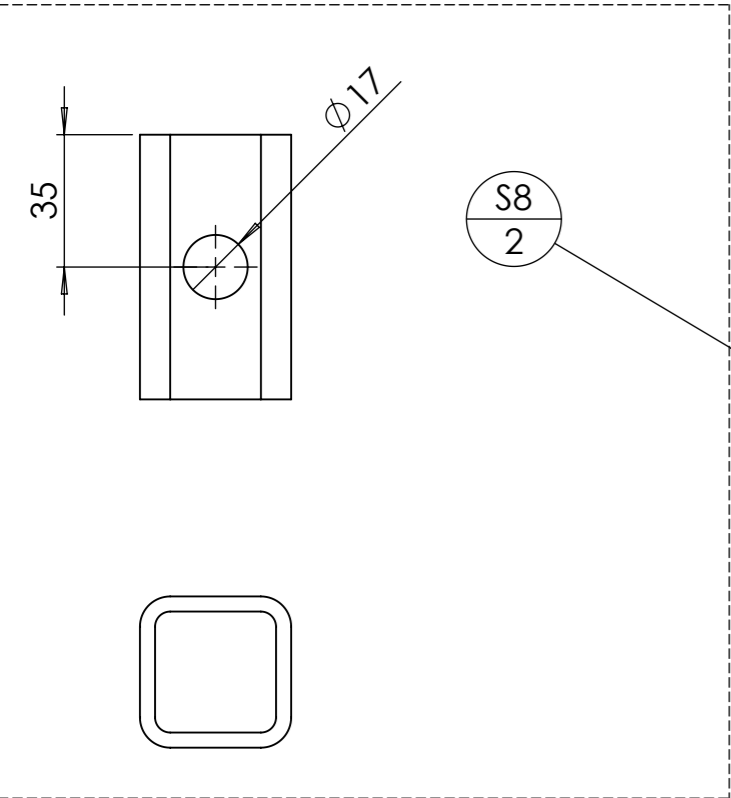

Outil	Cadre ST large			
Date	30/07/2021	Version	4.0	
page n°	7	/ 13		
Feuille	V large position			

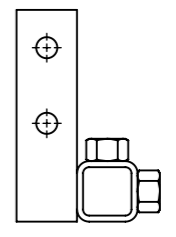
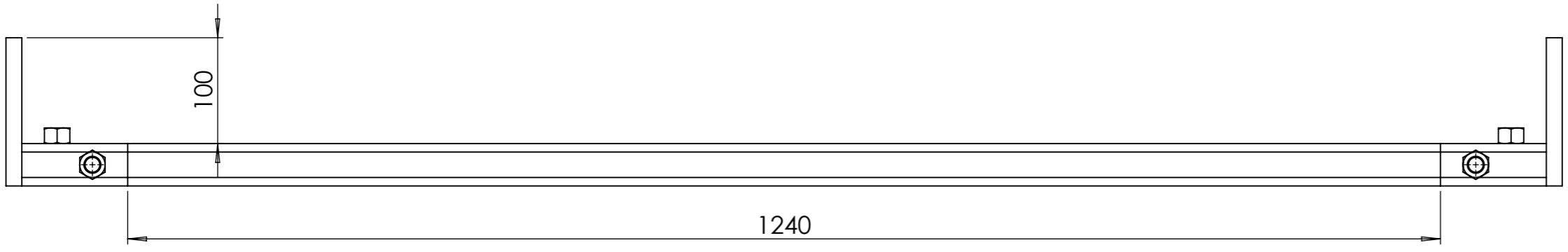
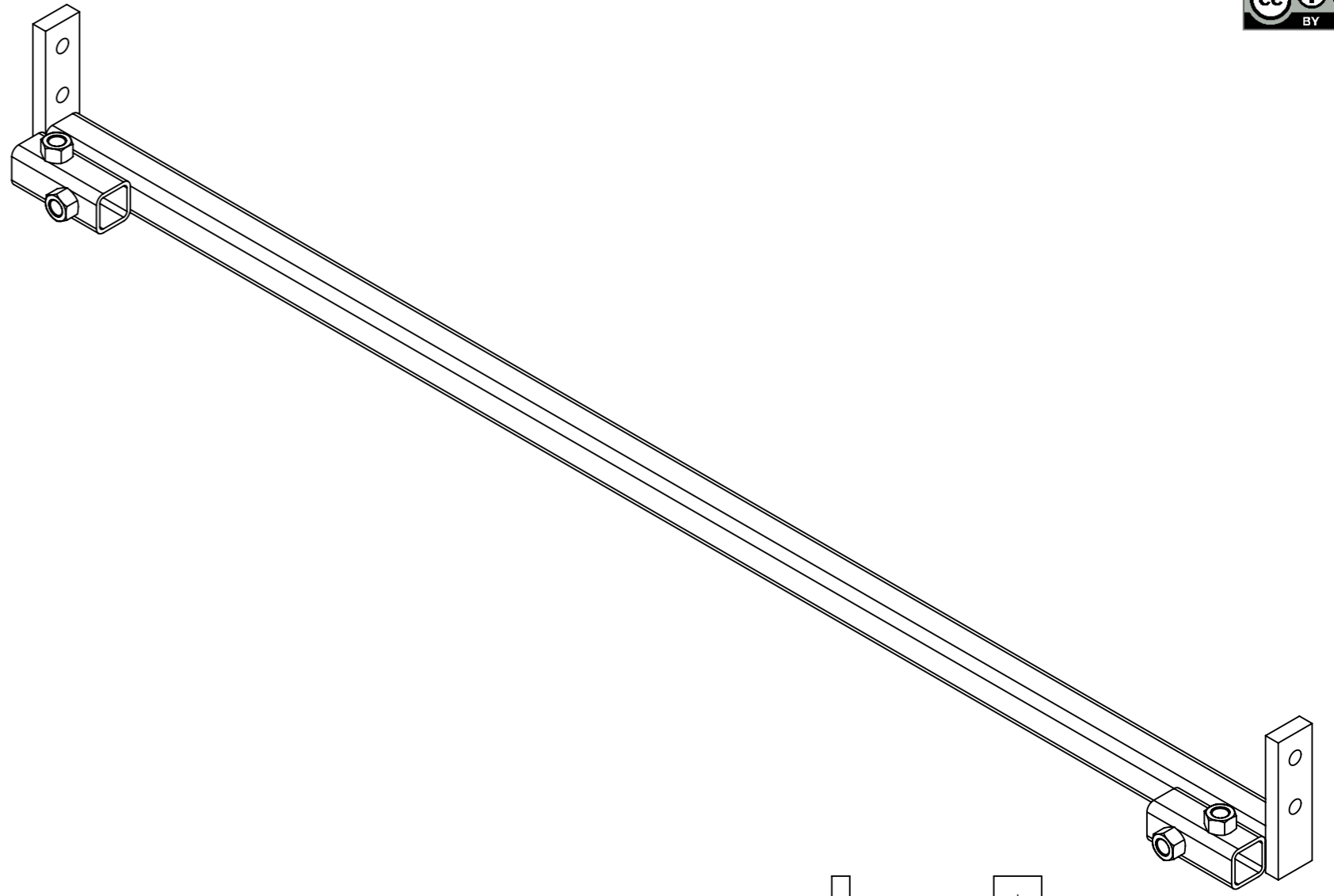

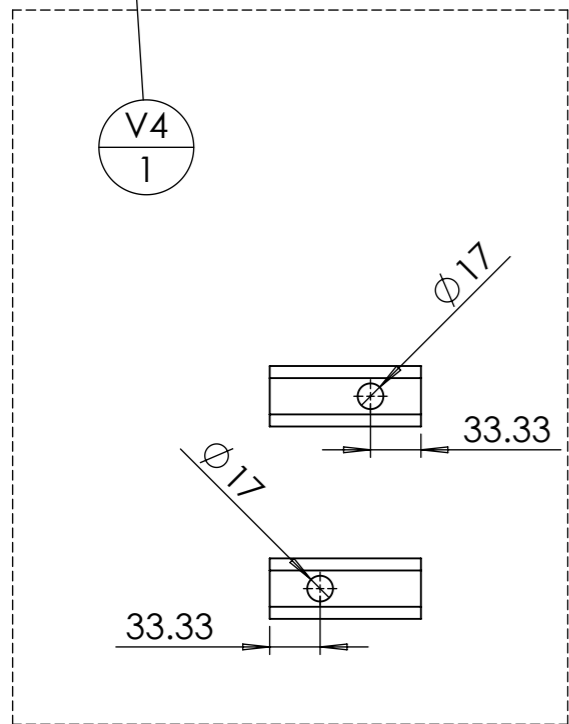
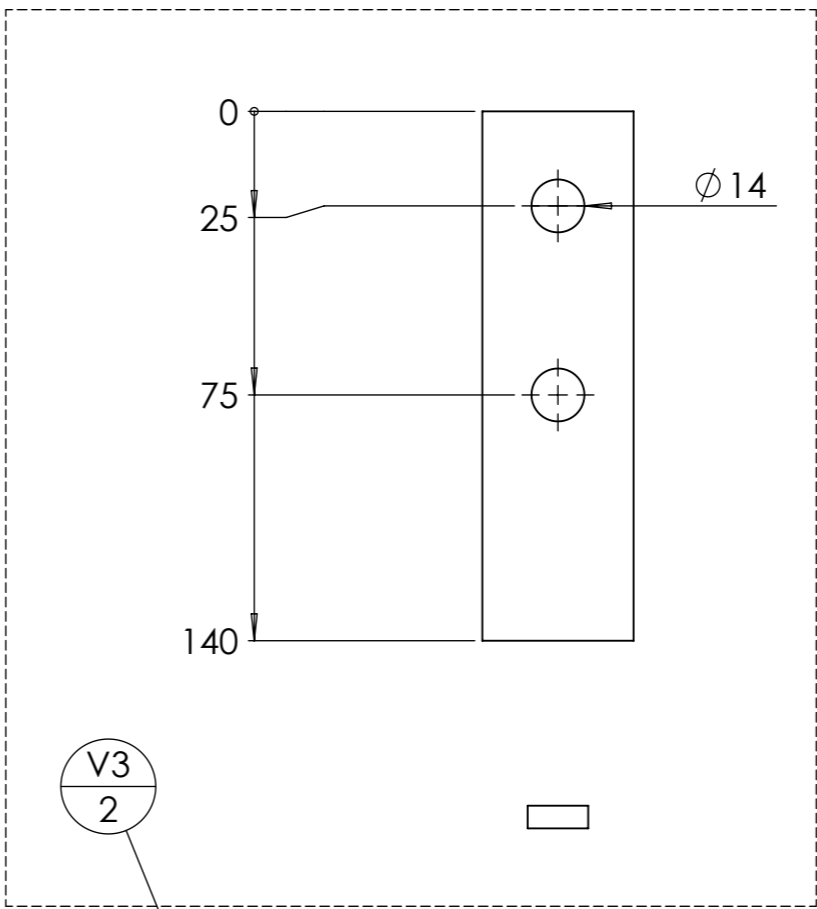
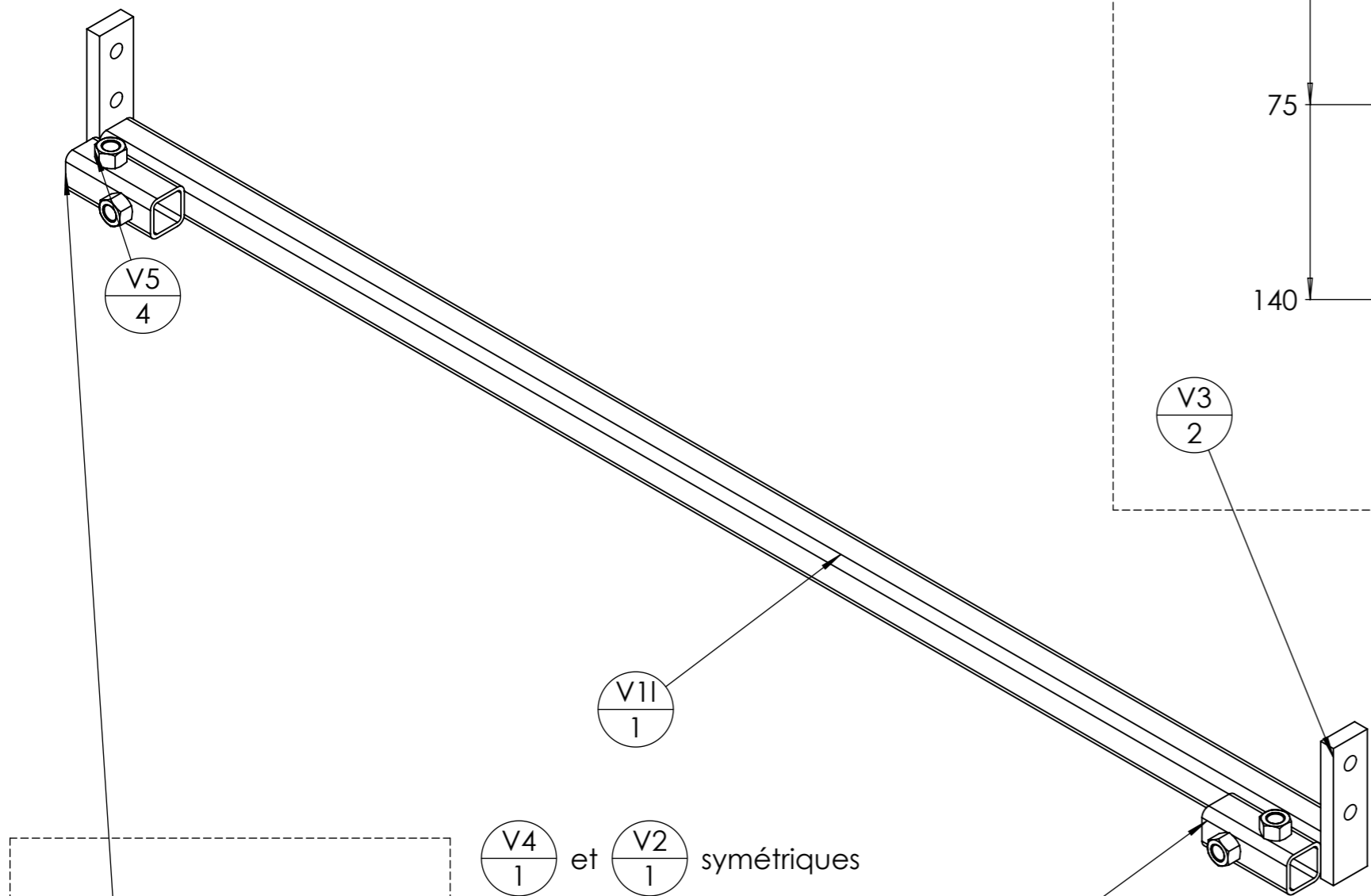

V4 et V2 symétriques

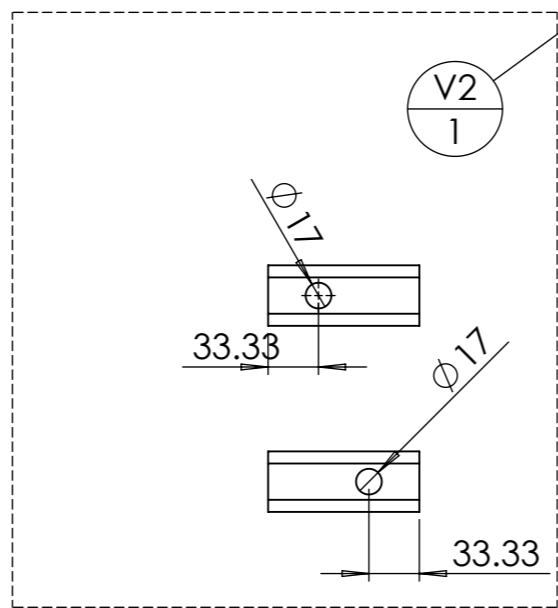

ID	Description	ANGLE1	ANGLE2	p	Longueur	Qté
V11	tube carré 40 x 4	0.00	0.00		1440	1
V2	tube carré 40 x 4	0.00	0.00	2x Ø17 ;	100	1
V3	Fer plat 40 x 15	0.00	0.00	2x Ø14 ;	140	2
V4	tube carré 40 x 4	0.00	0.00	2x Ø17 ;	100	1
V5	Ecrou M16 brut					4



Des tenons-mortaises facilitent l'assemblage.

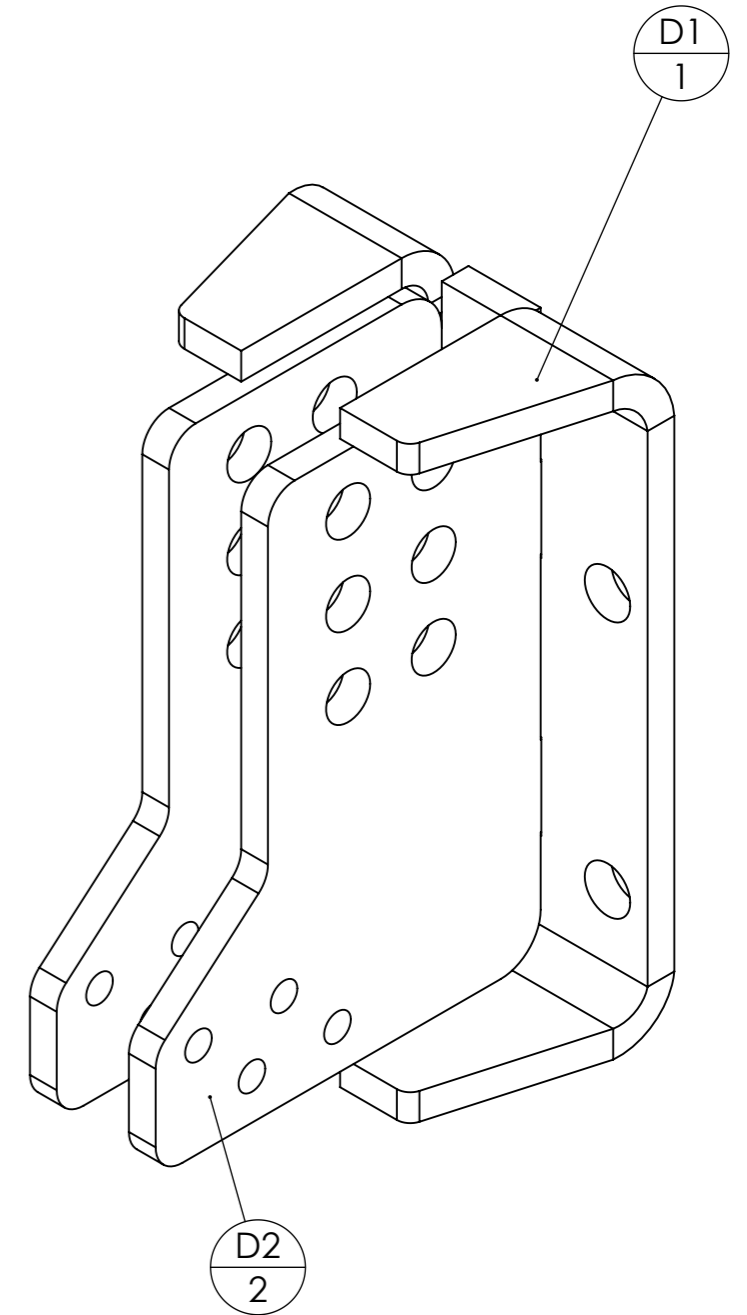
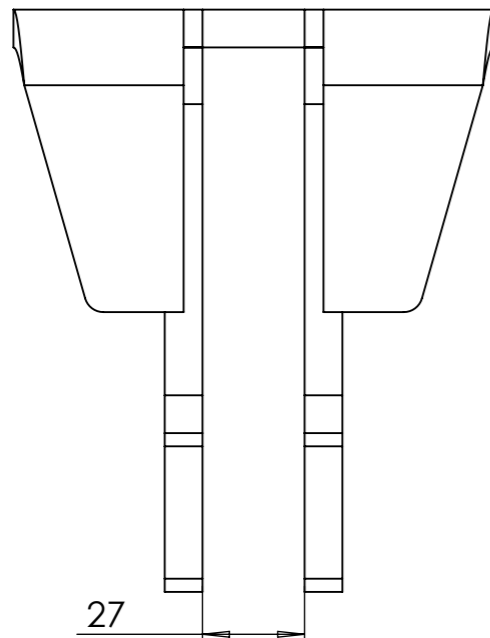
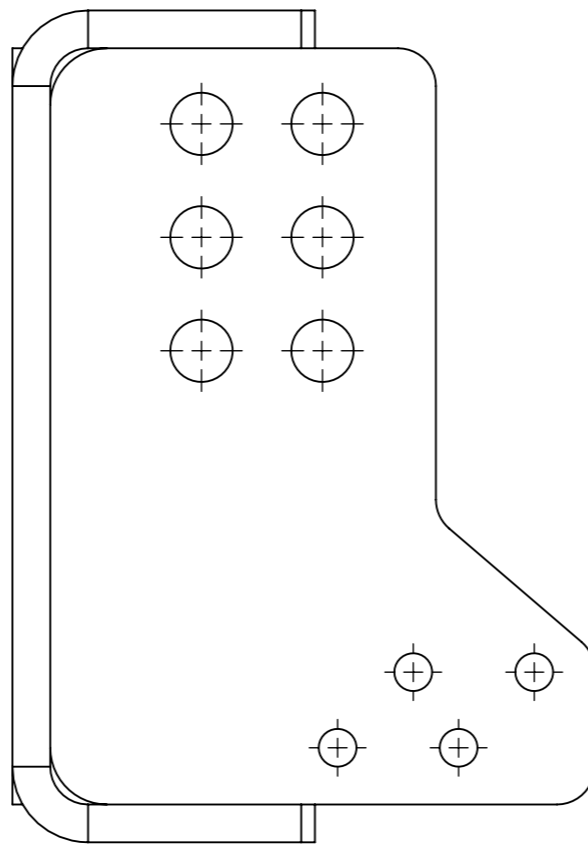
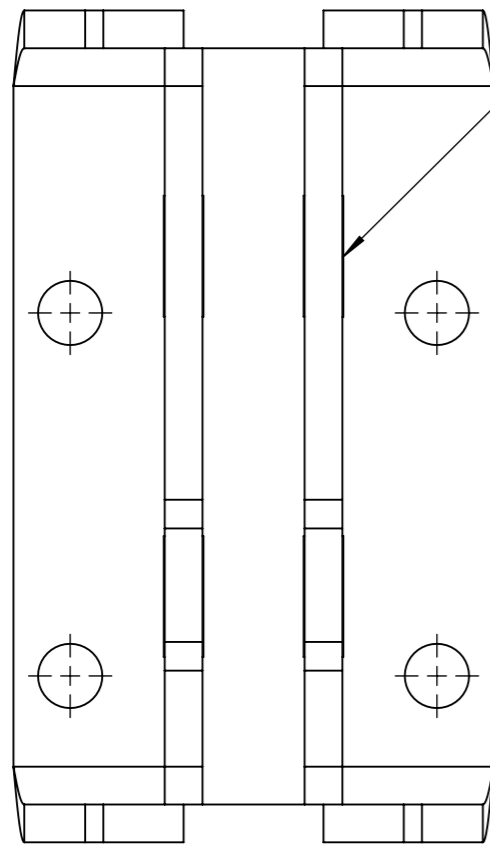

ID	Description	Qté
D1	châpe de fixation sur bâti de 80	1
D2	châpe mobile pour dent de semoir	2

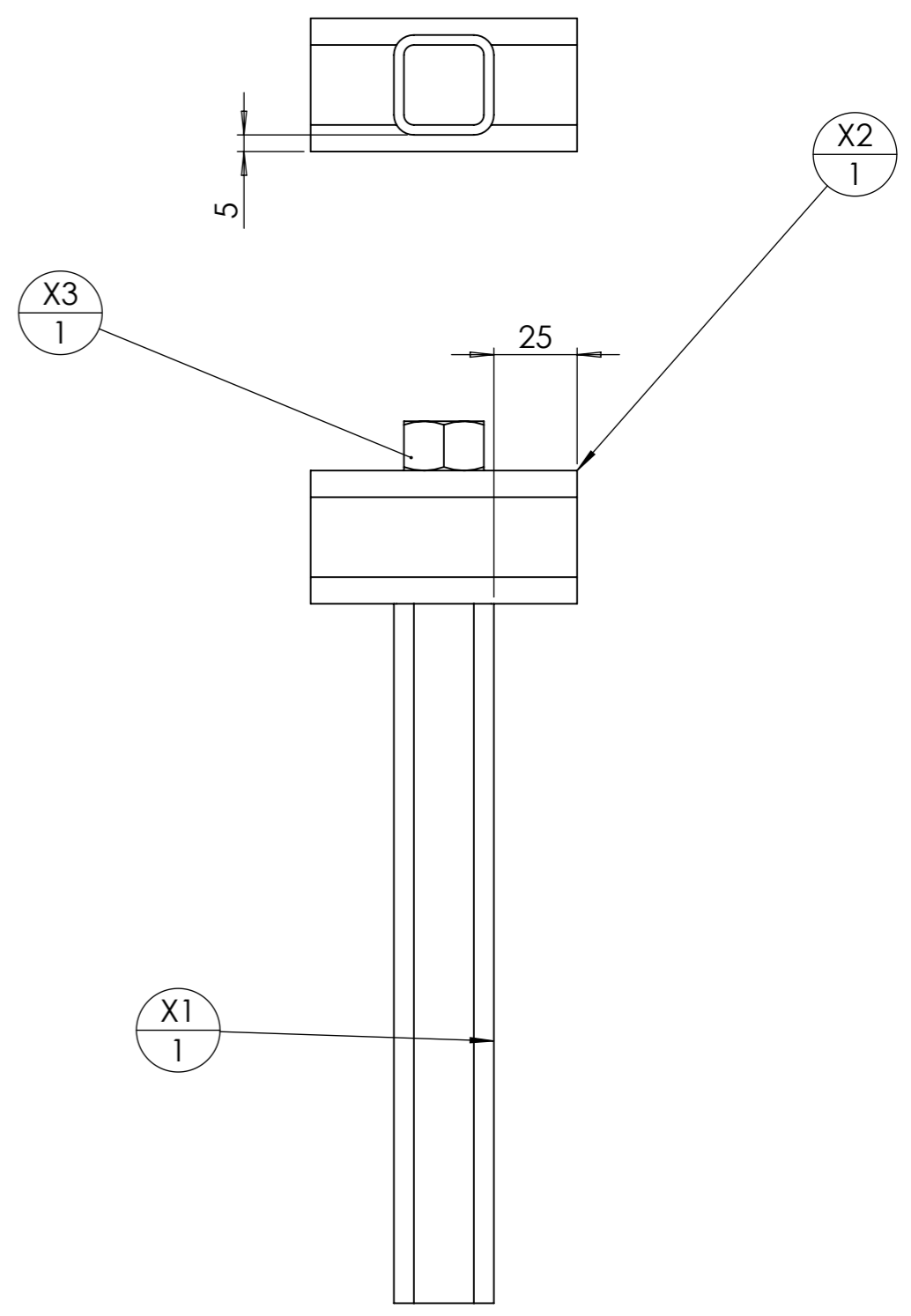
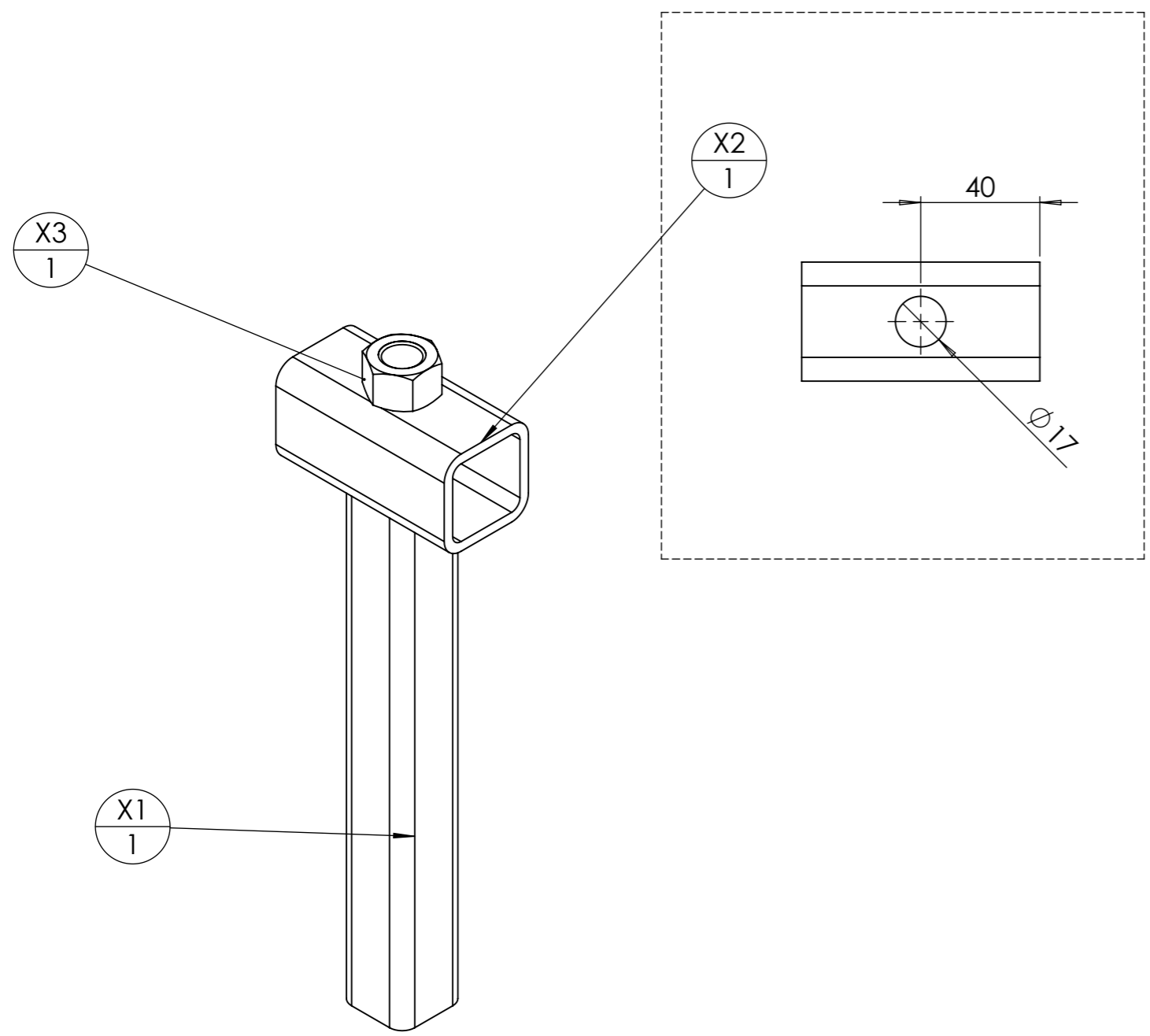

ID	Description	ANGLE1	ANGLE2	p	Longueur	Qté
X1	tube carré 30 x 3	0.00	0.00		210	1
X2	tube carré 40 x 4	0.00	0.00	1x Ø17 ;	80	1
X3	Ecrou M16 brut					1

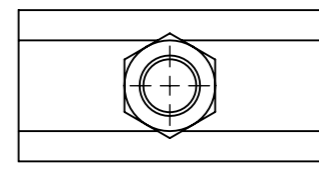

Outil	Cadre ST large				
Date	30/07/2021	Version	4.0		page n° 11 / 13
Feuille	Y				

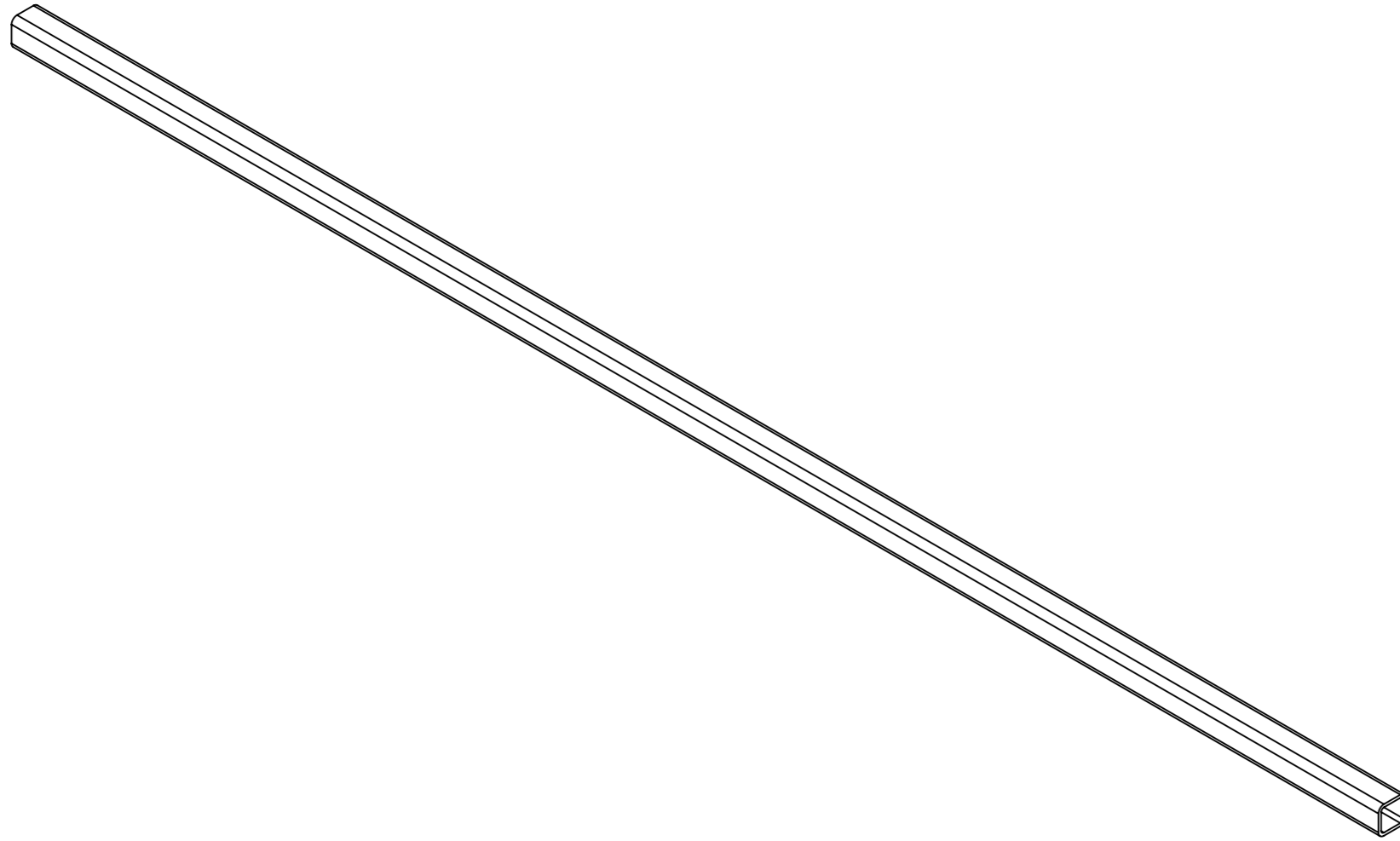

ID	Description	ANGLE1	ANGLE2	p	Longueur	Qté
Y11	tube carré 30 x 3	0.00	0.00		1500	1

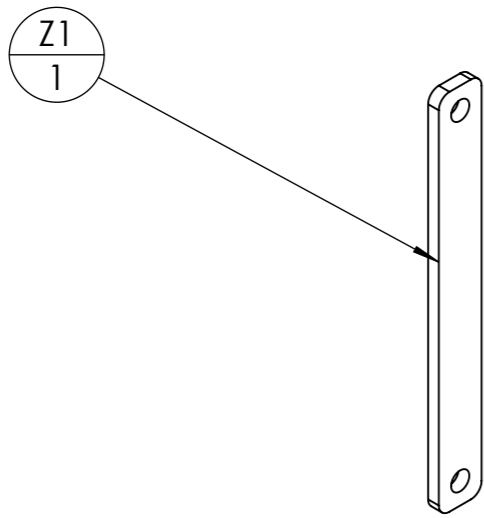

ID	Description	ANGLE1	ANGLE2	p	Longueur	Qté
Z1	Fer plat 40 x 10	0.00	0.00	17	340	1

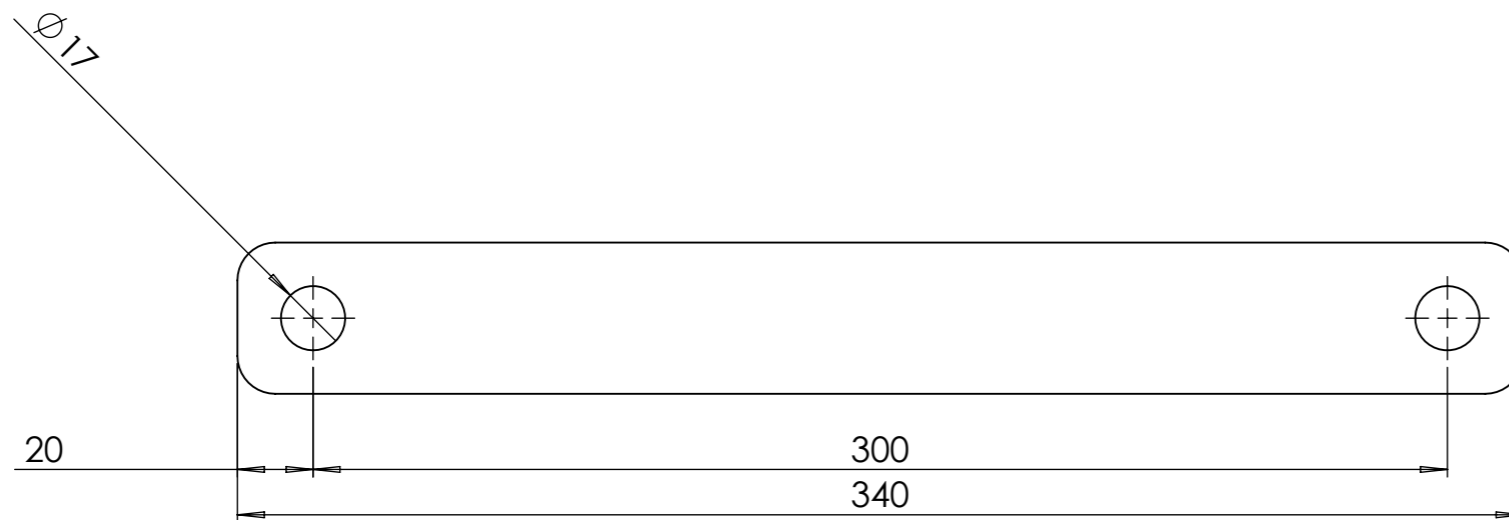

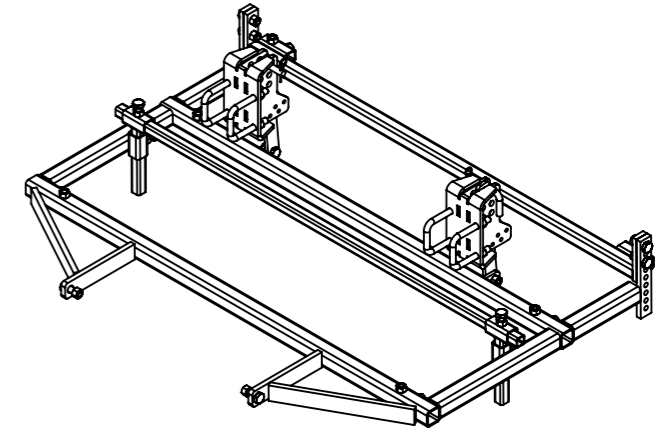

repère	Désignation	ANGLE1	ANGLE2	p	LONGUEUR	Quantité
S	chassis bas large					1
S11	tube carré 50 x 5	0.00	0.00	17	1500	2
S2	tube carré 50 x 5	0.00	0.00		250	2
S4	fer plat 50 x 15	0.00	0.00	22	260	2
S51	fer plat 50 x 15	0.00	0.00		401.4653	2
S6	Fer plat 40 x 15	0.00	0.00	14	250	2
S9	Fer plat 40 x 10	0.00	0.00	16	50	2
S10	Ecrou M16 brut					10
S3	tube carré 50 x 5	0.00	0.00		450	2
S8	tube carré 40 x 4	0.00	0.00	17	70	2
V	barre porte dent					1
V11	tube carré 40 x 4	0.00	0.00		1440	1
V2	tube carré 40 x 4	0.00	0.00	2x Ø17 ;	100	1
V3	Fer plat 40 x 15	0.00	0.00	2x Ø14 ;	140	2
V5	Ecrou M16 brut					4
V4	tube carré 40 x 4	0.00	0.00	2x Ø17 ;	100	1
X	support barre porte cuillère					2
X1	tube carré 30 x 3	0.00	0.00		210	1
X2	tube carré 40 x 4	0.00	0.00	1x Ø17 ;	80	1
X3	Ecrou M16 brut					1
Y	barre porte cuillère					1
Y11	tube carré 30 x 3	0.00	0.00		1500	1
Z	bras support module bas					2
Z1	Fer plat 40 x 10	0.00	0.00	17	340	1
D + bride U						2
D	Bride viticole					1
D1	châpe de fixation sur bâti de 80					1
D2	châpe mobile pour dent de semoir					2
Bride en U pour bâti de 80	Bride en U pour bâti de 80					2
Ecrou	Ecrou M16 autofreiné					4
Vis Hexagonale	Vis hexagonale M16 x 35					6
Ecrou	Ecrou M16 autofreiné					8
Vis Hexagonale	Vis hexagonale M16 x 50					6
Broche Ø16 L100 avec goupille	Broche Ø16					2
Broche Ø16 L100	Broche Ø16 L100					1
Broche 1 - 16 L100	Broche pliée Ø16 - L100			5		1
Broche 1 - 16 L100	étiré rond Ø16	0.00	0.00	5	175.13	1
Goupille épingle d'axe, 15x70 Ø4	Goupille épingle d'axe 15x70 Ø4					1