

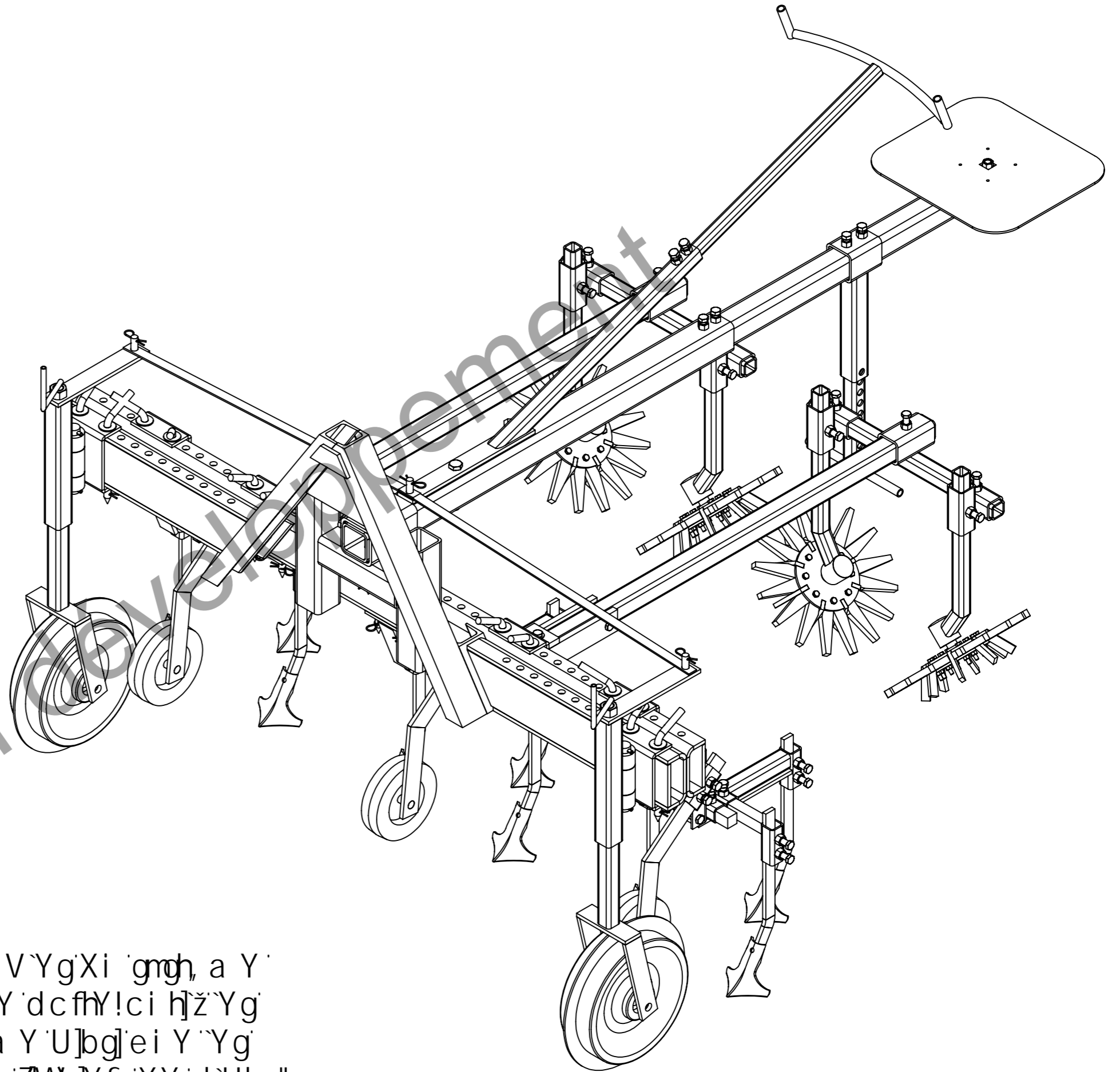

J Yfgjcb	%"\$ E hf	%	
8UH	&* # \$+ #&\$%*		
Ci h	6]bYi gY' fhc]Y		
D], W	J i Y'XffbgYa V`Y		



7 Y `d `Ub `Xf Z]b]h`Yg'd], Wg`Yh`YbgYa V`YgXi `gmh, a Y`  
 XY `X]fY W]cb `XY `U `V]bYi gY" @U `VUffY `dcfhY!ci h]ž`Yg`  
 f`fa YbhV]bYi fgj fdUfU`f`c[ fUa a Y`U]bg]ei Y`Yg`  
 V]bYi gYg`fhc]YgZc bh`fc V`YhXfwi hfYgZ]M]YfgXY `d `Ubg`

J Yfgjcb	%"\$	E hf	%	
8 UHY	&* # \$ + # & \$ % *			
C i h	6]bYi gY`f h c]Y			
D]r WY	9bWta VfYa Ybh			

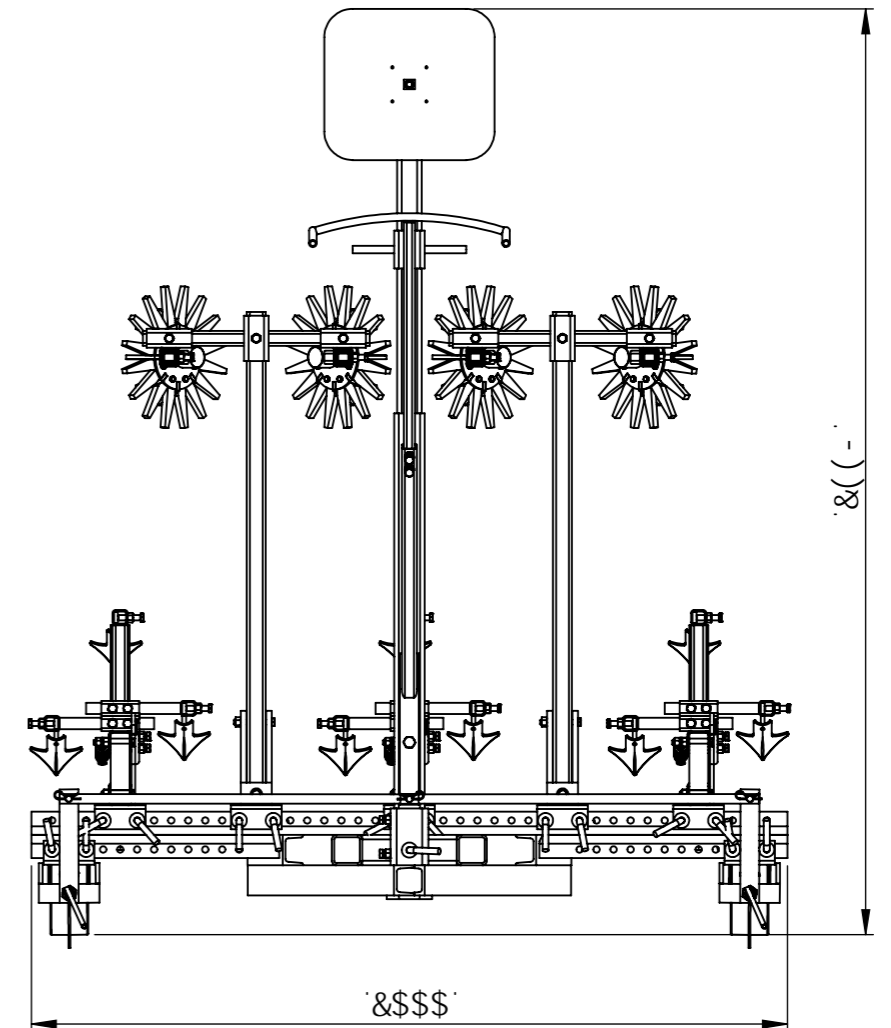
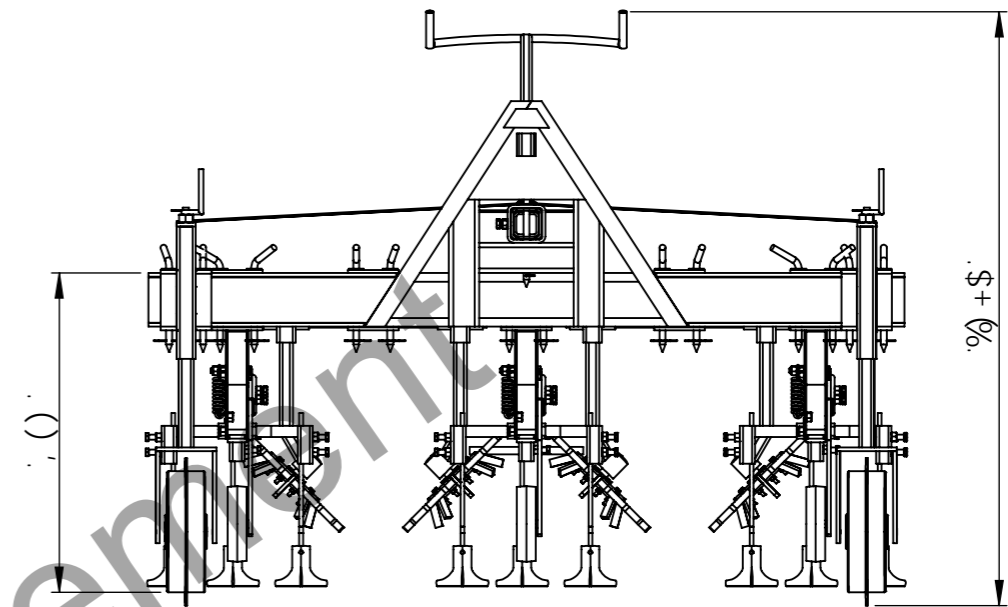
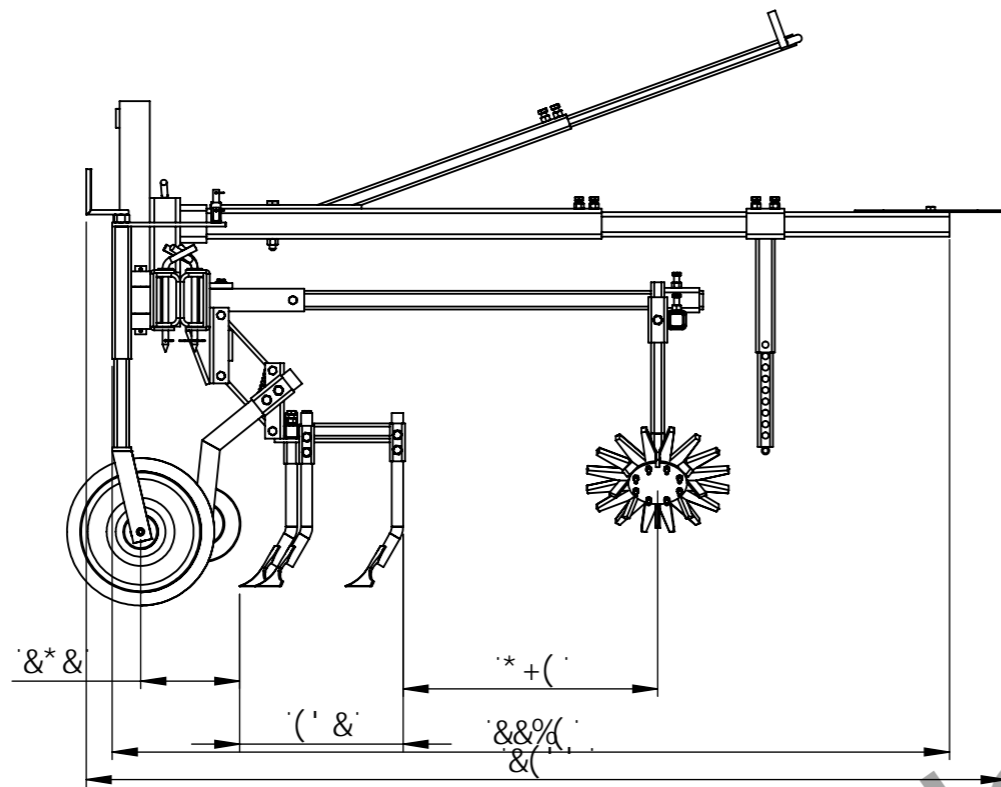

7' hYg'XcbbfYg'Uj YWhci g`Yg'f`fa Ybhg'  
 ff[ `UV`Yg'dc g]h]cbbf gYb`YI hYbg]cb`a UI]a U`Y

En développement

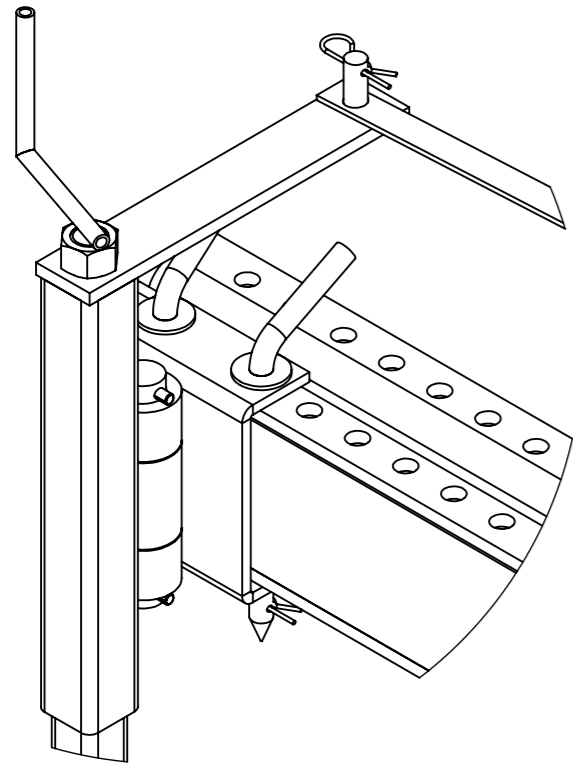

8vH5 @5  
97 < 9@9 %.)

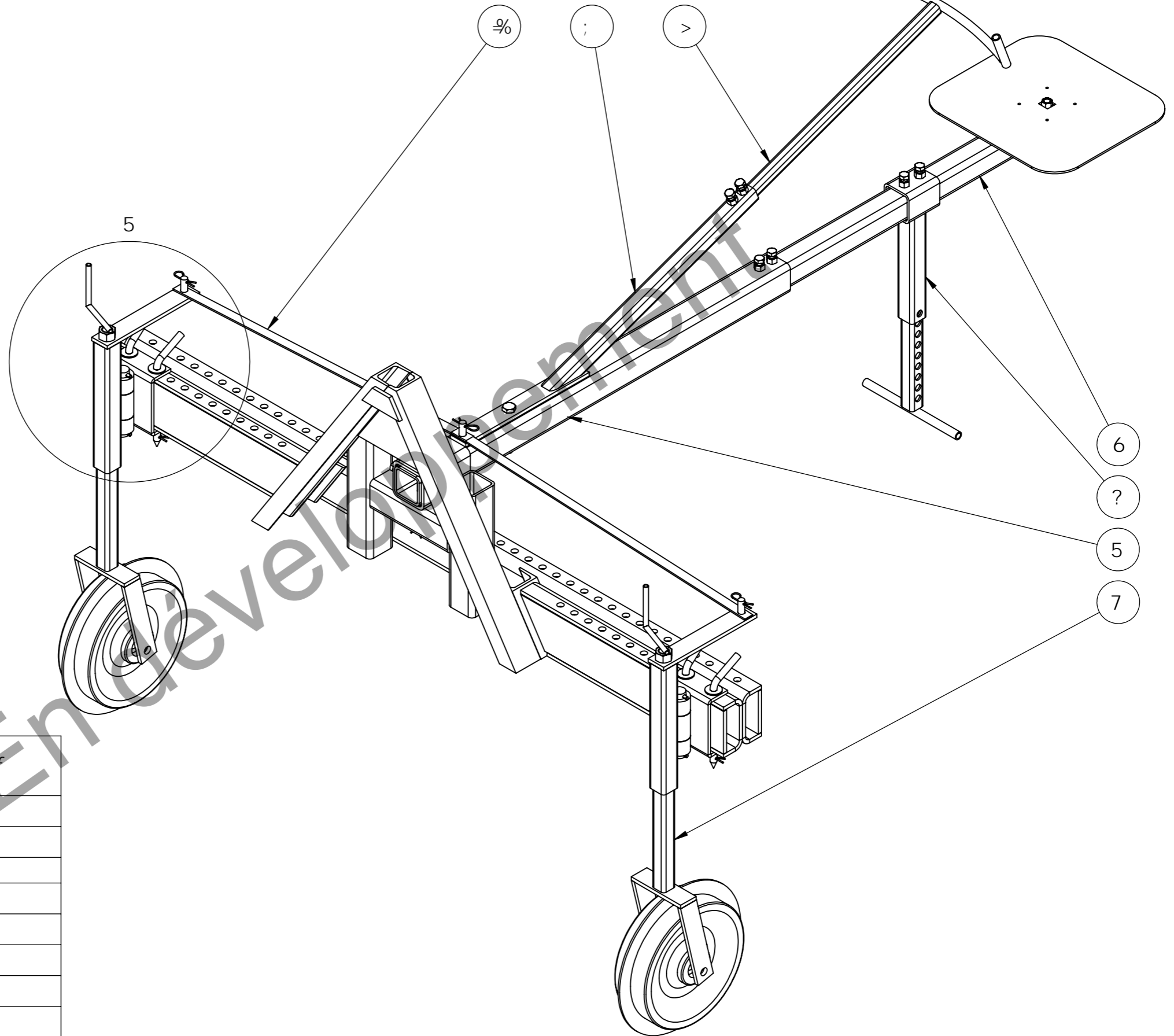

Bš	8fgl bUhc b	E i Ubhly
%	5	%
&	6	%
'	6UffY Dc fhY! C i h]g	%
(	7	&
)	:Yfd`Uh&) I` (	&
*	;	%
+	>	%
,	?	%
-	J ]g\YIU[ cbU`Y`A %( I` \$	*
%"\$	J ]g\YIU[ cbU`Y`A %* I` %&\$	%
%%	9Wfc i `A %* `Ui hc ZY ]bf	%

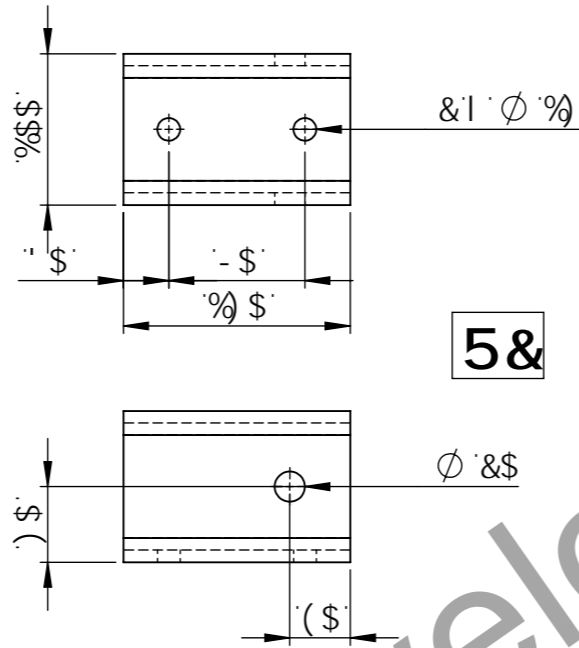
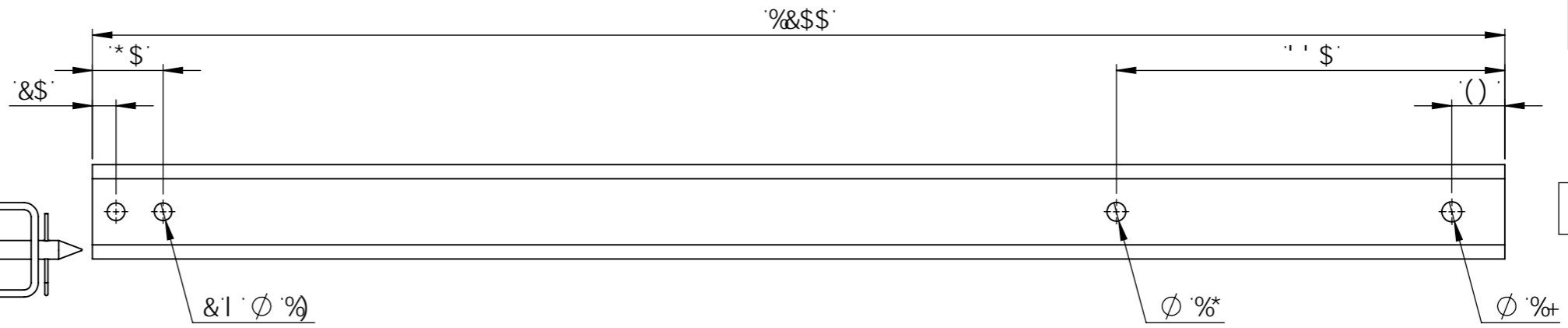
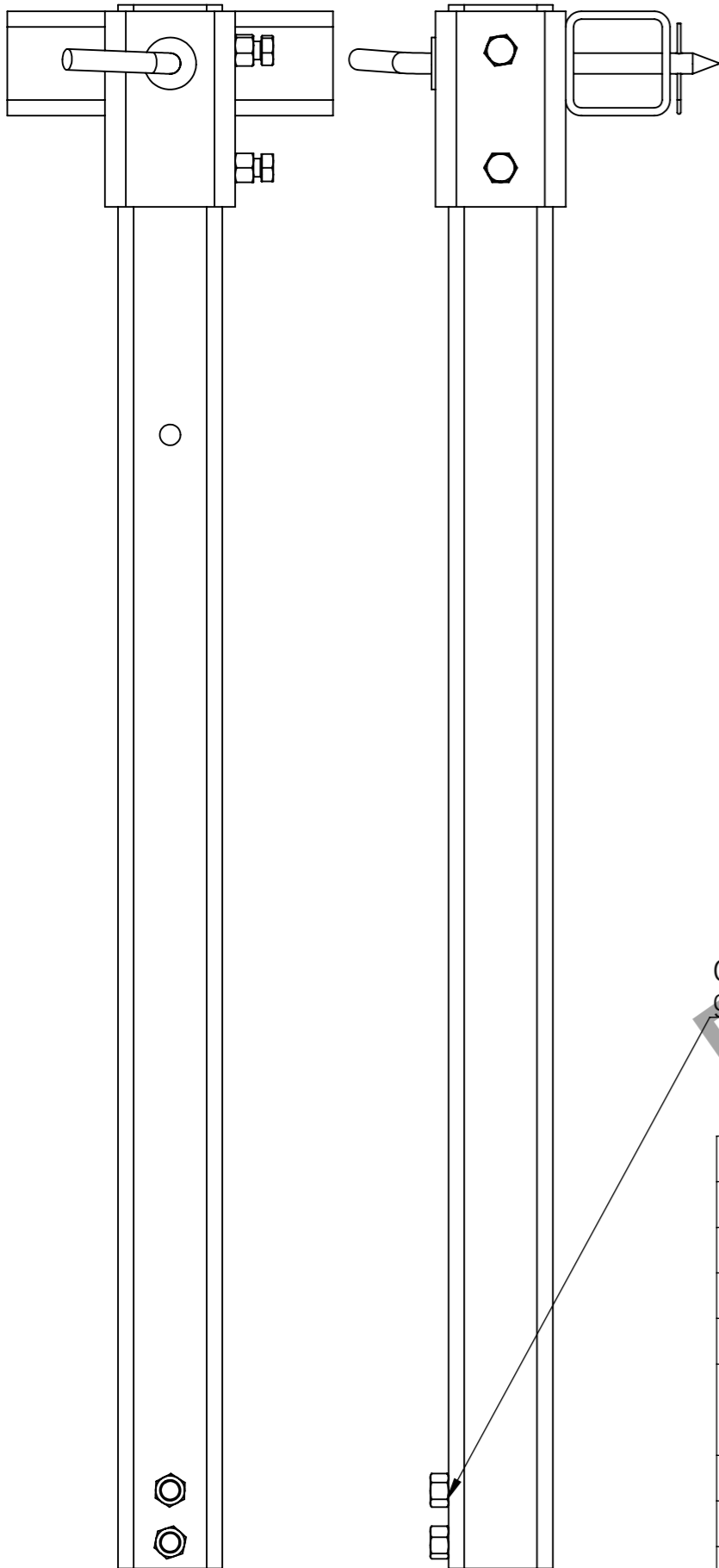

5&

5%

@' h VY ' 5% ] Y b h g Y ' g c i X Y f Y b h f Y ' Y g f Y b z c f g X i ' h f U b [ ' Y X f u h Y ' U [ Y X Y ' U ' V U f f Y ' d c f h Y ' c i h ]

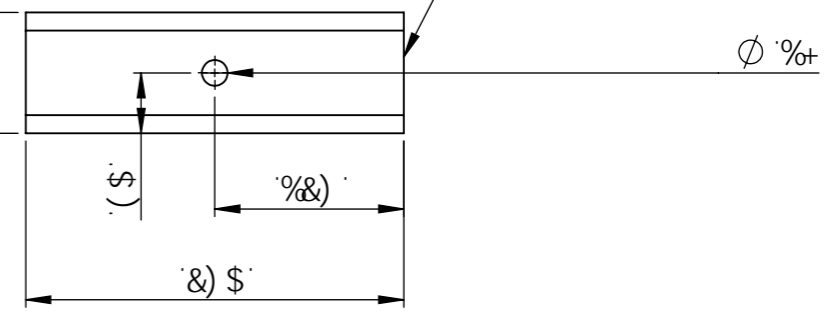

Gci XYfXYi l fWci gA %  
 g f Yghci gXY ' 5 & Yh5'

Bš	8 f g l [ b U h c b	@ b [ i Y i f	E hf
5%	h i VY ' W u f f ' , \$ l ' *	& ) \$	%
5&	h i VY ' W u f f ' % \$ \$ l ,	% ) \$	%
5'	h i VY ' W u f f ' , \$ l ' *	% & \$ \$	%
9 W f c i	9 W f c i ' A % \ V f i h		(
; c i d ] Y ' f d ] b [ ' Y ' X f u l Y ž % l + \$ ' « (	; c i d ] Y ' f d ] b [ ' Y ' X f u l Y ž % l + \$ ' « (		%
F c b X Y ' Y	F c b X Y ' Y ' « % * ' g f f ] ' @		%
D%	f h f f ' f c b X ' « % *	' & \$	%
J ] g < Y I U [ c b U Y	J ] g \ Y I U [ c b U Y ' A % \ l ' ' \$		&

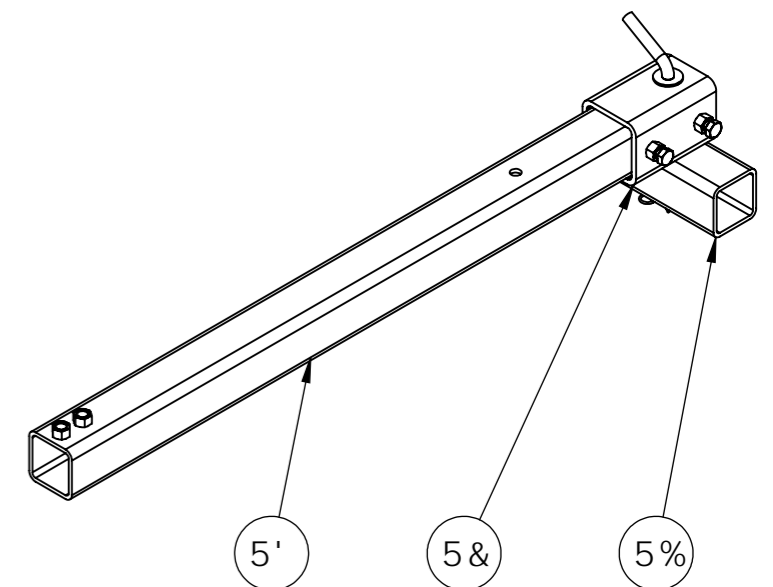

J Yfgjcb	%"\$ E hf	%	
8UH	&* # \$ + # & \$ % *		
C i h	6]bYi gY f h c]Y		
D]r W	9bgYa V`Yg'6ž8		

6

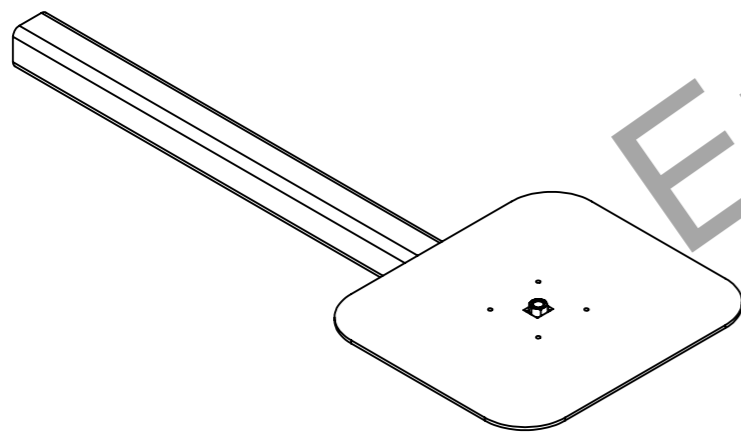
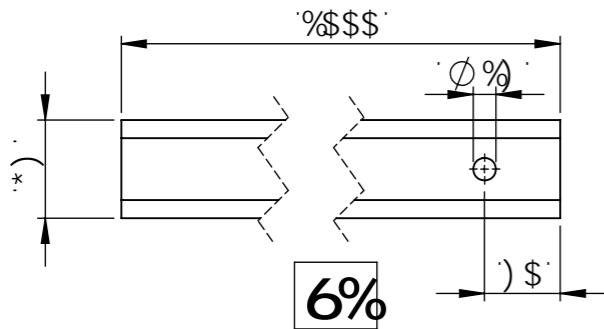

Bš	8fgl[ bUh]cb	@b[i Yi f	E hf
6%	h VY`Wuff`*)`I`*`	\$\$\$\$	%
gY[ YSW j YH	G], [ Y`W j YH		%
9Wfci	9Wfci`A`%(`Vfi h		%

6

8

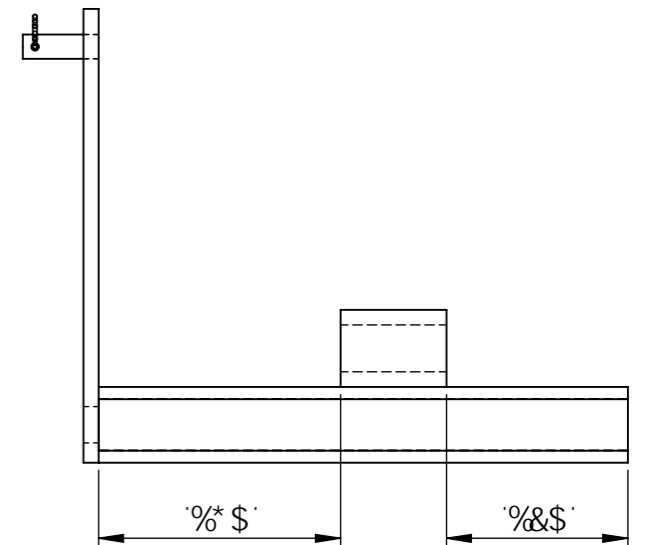
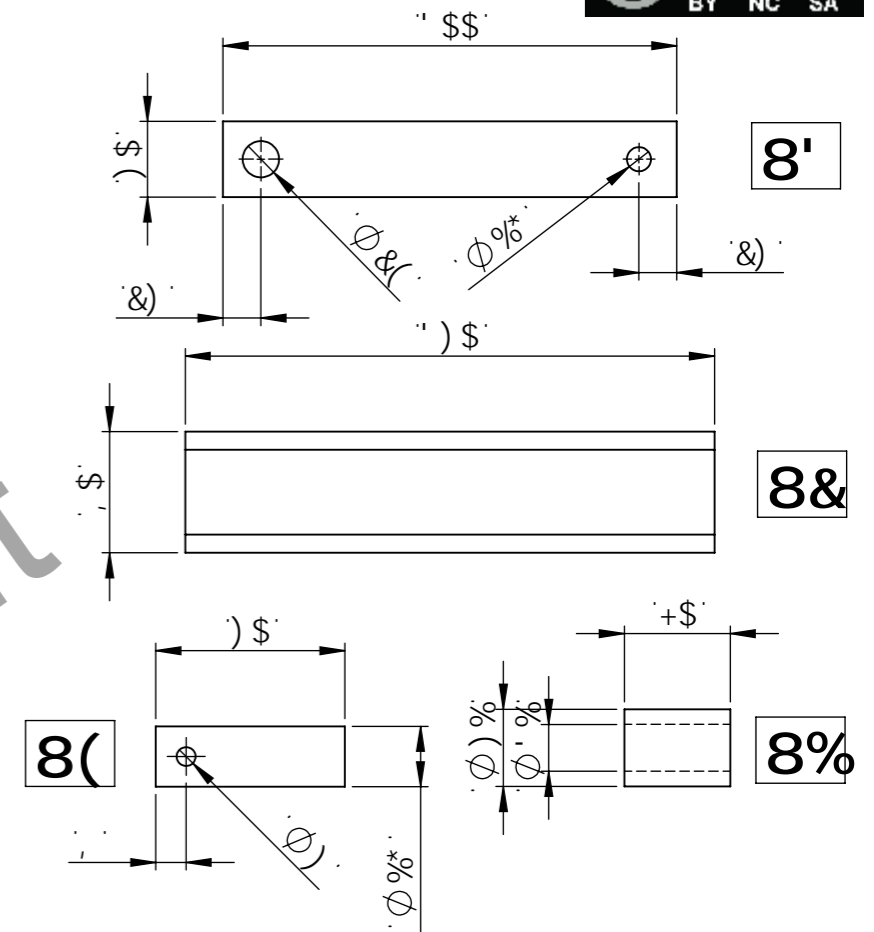
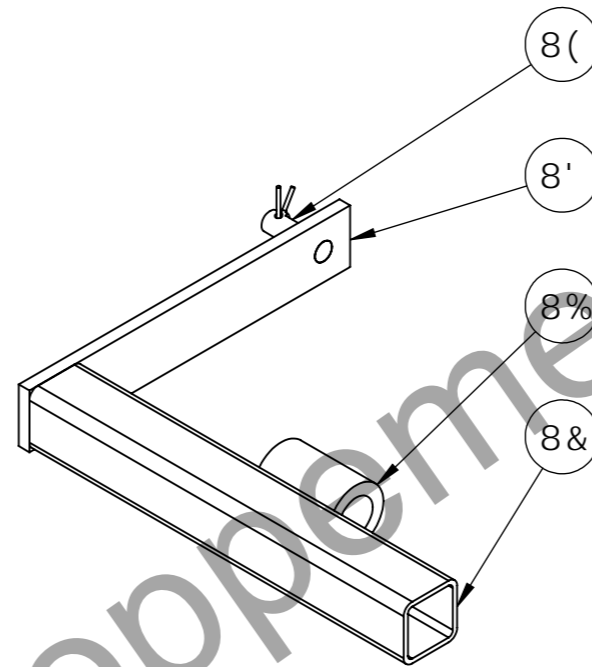

Bš	8fgl[ bUh]cb	@b[i Yi f	E hf
8%	fVUi WY`h Vi`U]fY`«`]bh`%`	+\$	%
8&	h VY`Wuff`)`\$i`(`	)\$	%
8'	:Yf`d`Uh)`\$i`%\$`	'\$\$	%
8(	f h]f`fcbX`«`%*`	)\$	%
; ci d]Y`fd]b[`Y`XfWl Yž%)`I`+`\$`«`(`	; ci d]Y`fd]b[`Y`XfWl Yž%)`I`+`\$`«`(`		%

8



En développement

J Yfgjcb	%"\$ E hf	%	
8 UH	&* # \$+ #&\$%*		
C i h	6]bYi gY f hc]Y		
D]r W	vWUhf '7		



Gci XYf`YgXYi l fWfci gA &\$ { "U h] Y ZYhfY`  
 Ui hci fXi ZYfd`Uh) \$! %žgubg`Y gY ffYf

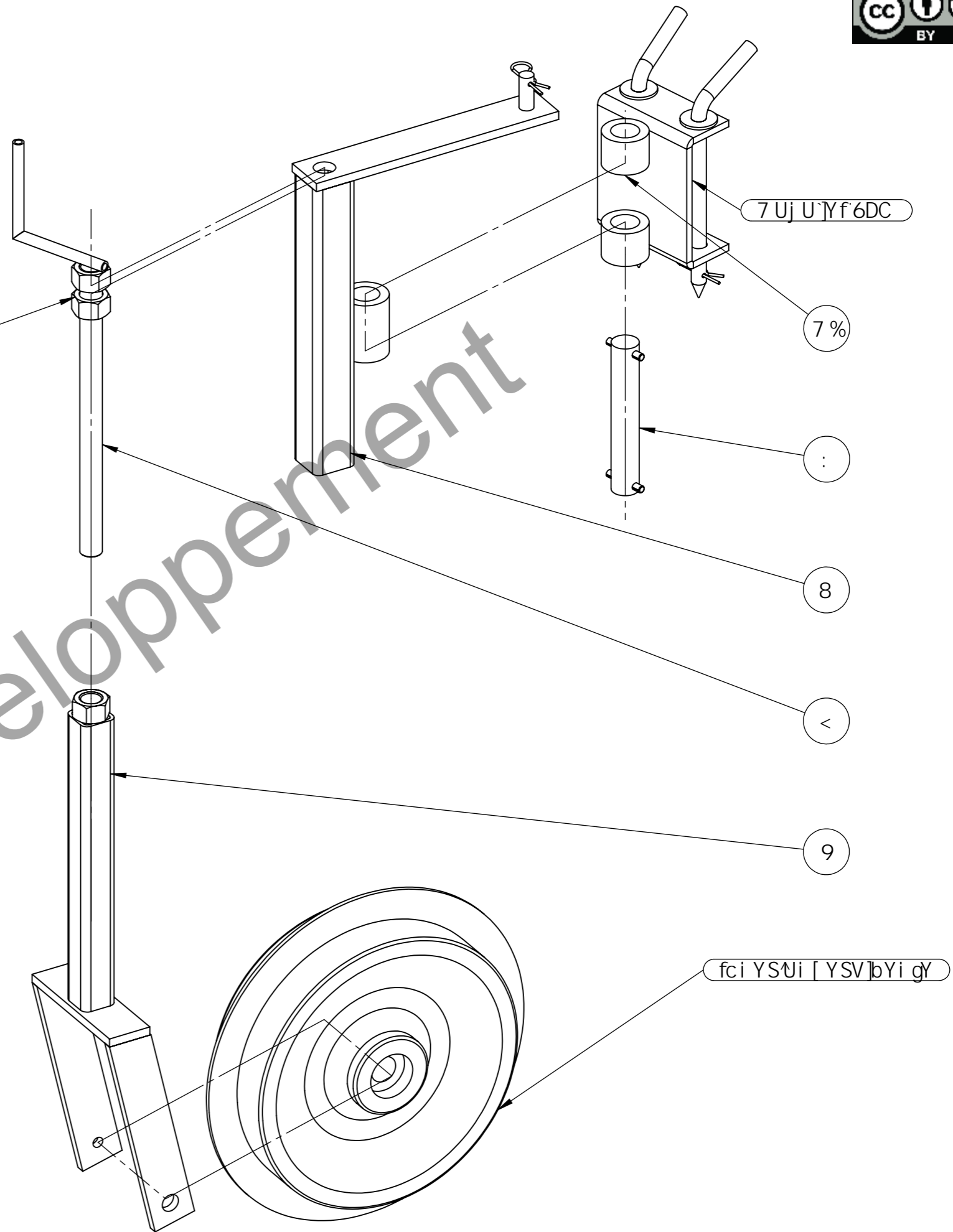
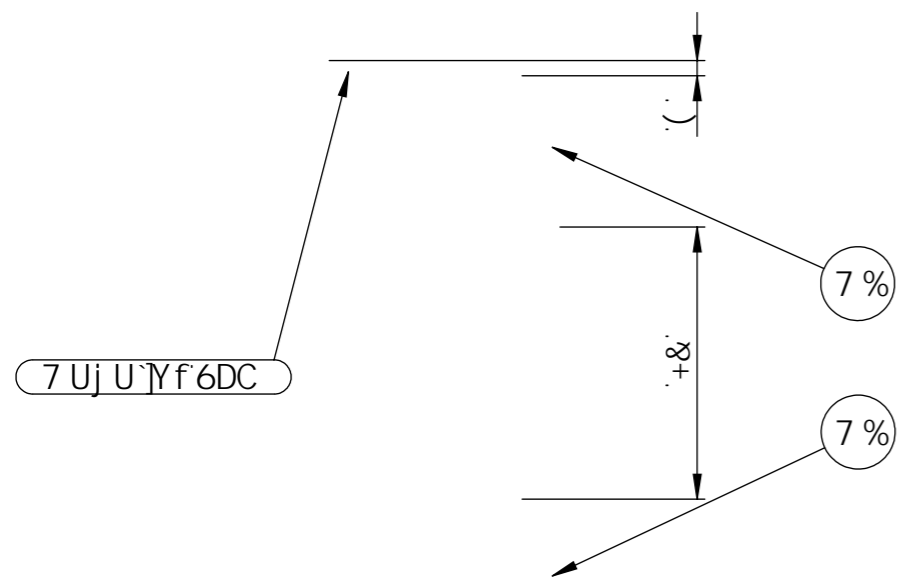

Bš	8fgj[ bUh]cb	E hf
%	7 Uj U`Yf`6DC	%
&	fVUi WXY`h Vi `U]fY`« ]bh' %	&
'	8	%
(	9	%
)	:	%
*	<	%
+	Fci Y`Yb`h`Y`« YIH &\$` « ULY' \$	%

J Y fgjcb	%"\$	E hf	%	
8 UH	&* # \$ + # & \$ % *			
C i h	6]bYi gY 'f h c]Y			
D]r W	9bgYa V`Y`9			

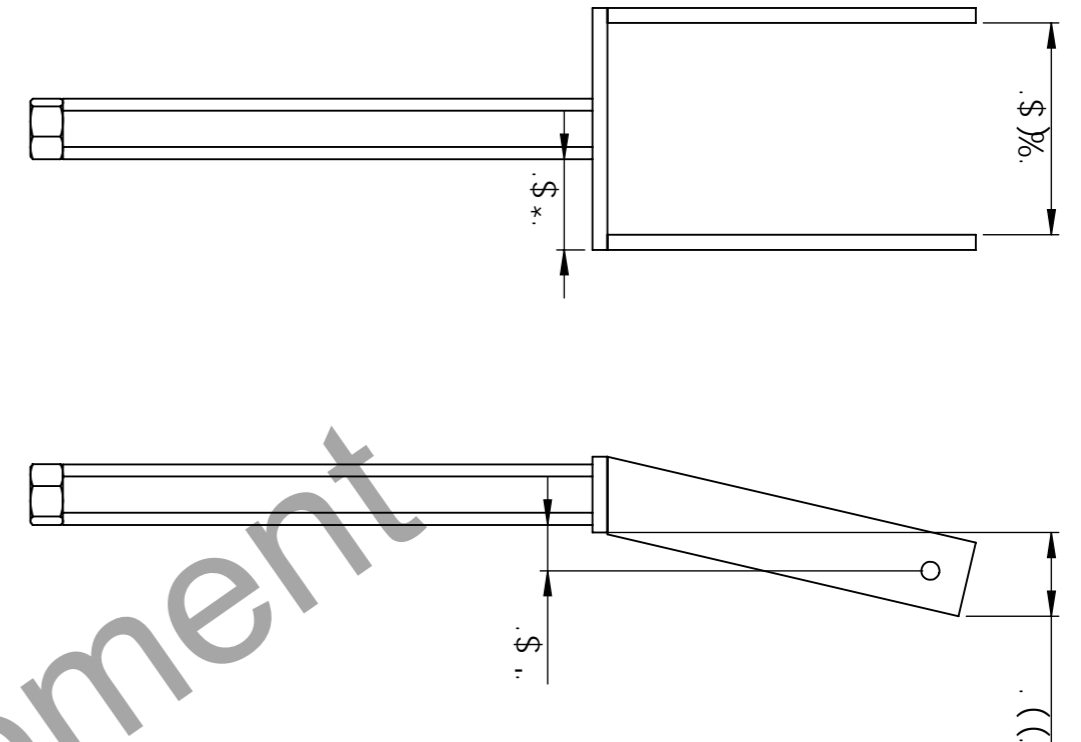
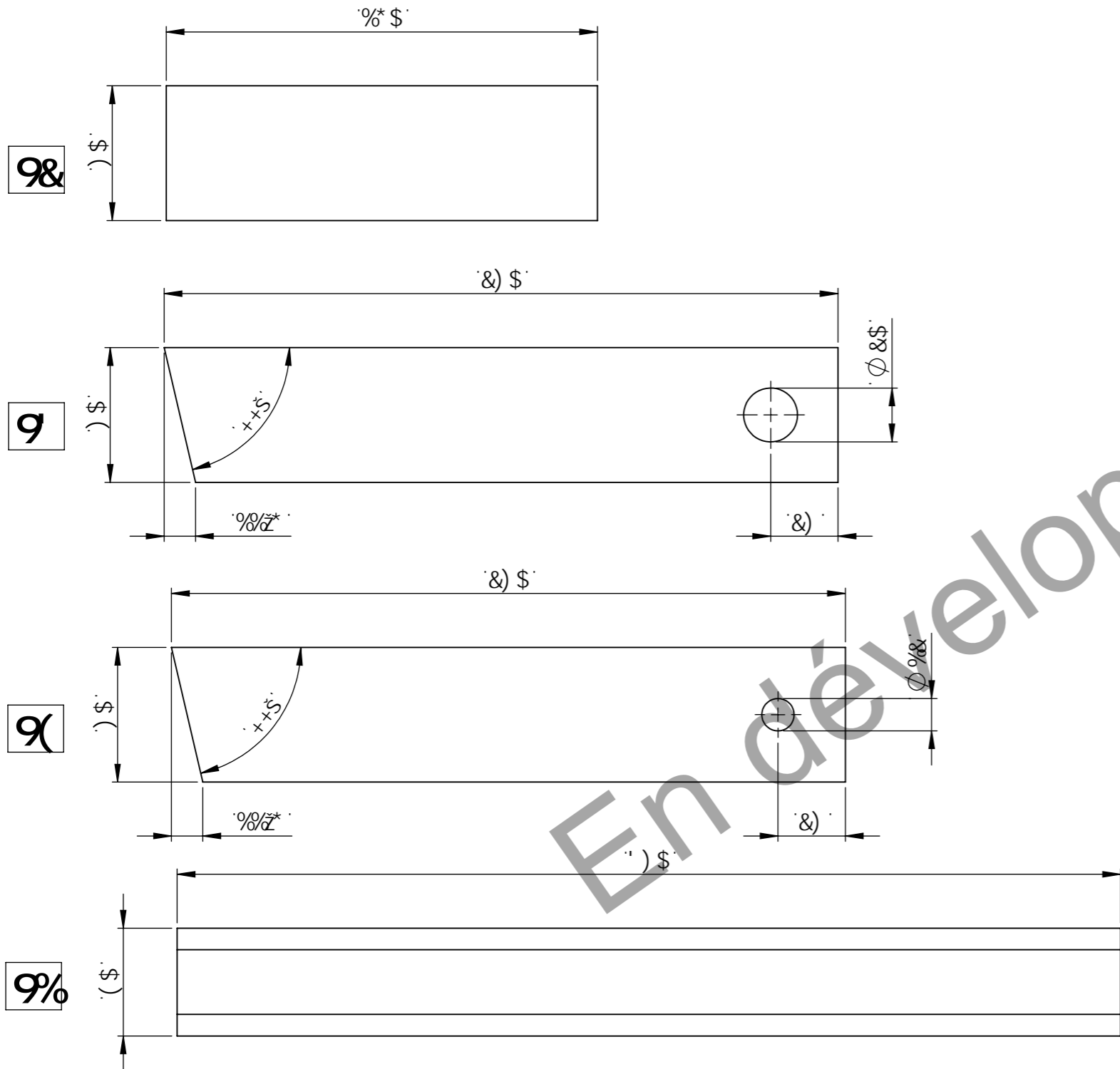

En développement

Bš	8 fgj[ bUh]cb	@b[ i Yi f	E hf
9%	hi VY`WUff'(\$'`(`	' ) \$	%
9&	:Yfd`Uh) \$'i`%\$	%* \$	%
9'	:Yfd`Uh) \$'i`%\$	& ) \$	%
9(	:Yfd`Uh) \$'i`%\$	& ) \$	%
9Wfci	9Wfci `A &( `N]b[ i f		%

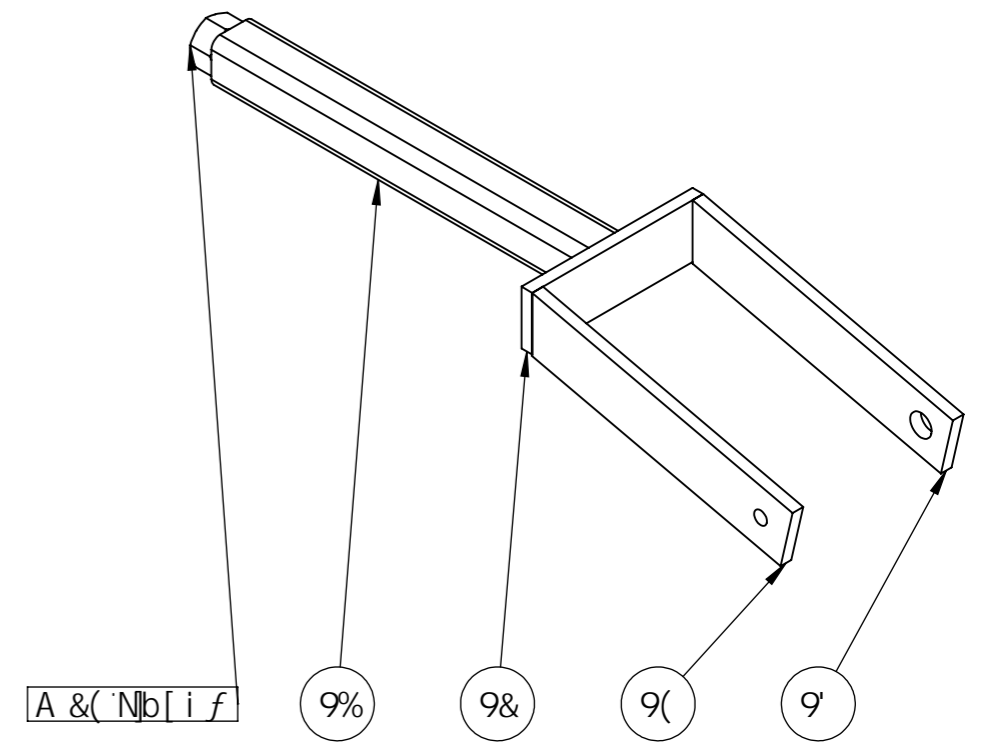

J Yfgjcb	%"\$ E hf	%	
8UH	&* # \$+ # & \$ %*		
C i h	6]bYi gY' f h c]Y		
D]r W	9bgYa VYg: ž; ž<		

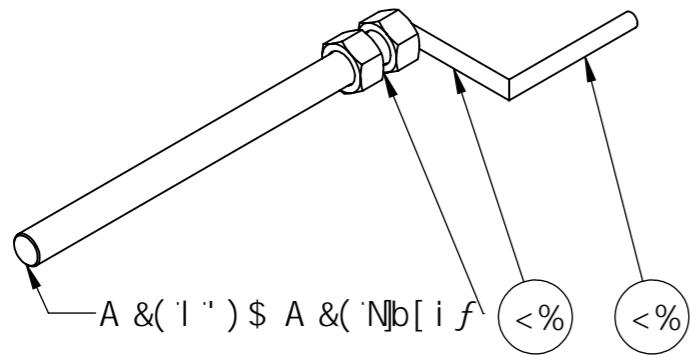
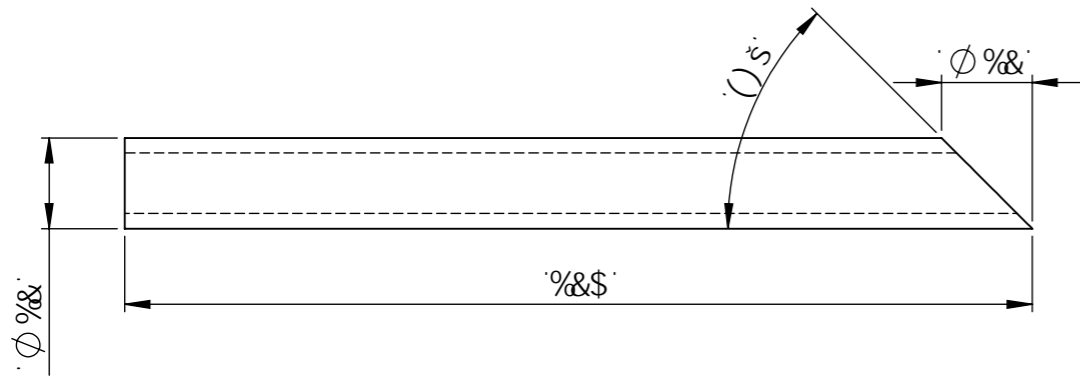

Bš	8fgl[ bUh]cb	@b[ i Yi f	E hf
9Wfci	9Wfci 'A &('N]b[ i f		&
h[ Y Z]YhfY' « &\$	H[ Y Z]YhfY' A &('l'' ) \$	' ) \$	%
<math><\%</math>	hi VY' fcbX' %&#36;l' &	%&#36;\$	&

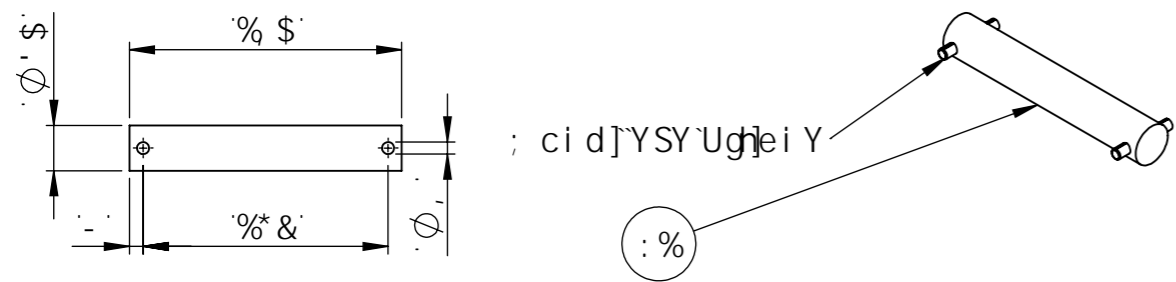

Bš	8fgl[ bUh]cb	@b[ i Yi f	E hf
: %	f h f f' fcbX' « ' \$	% \$	%
; ci d]YSY'Ug]ei Y	; ci d]Y' f' Ug]ei Y' ) \$ l' (		&

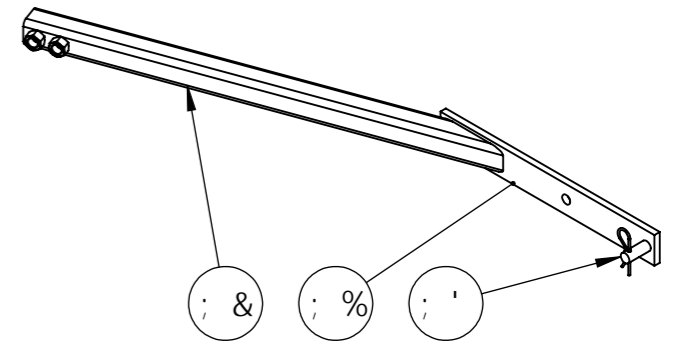
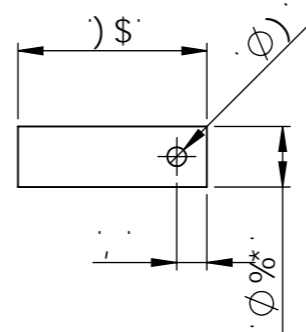
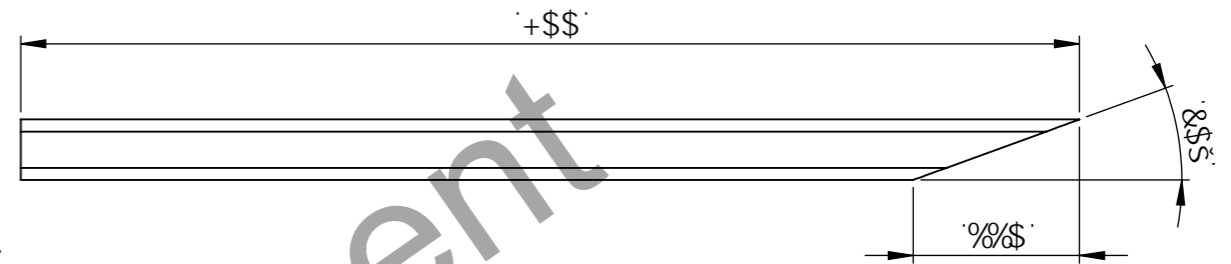
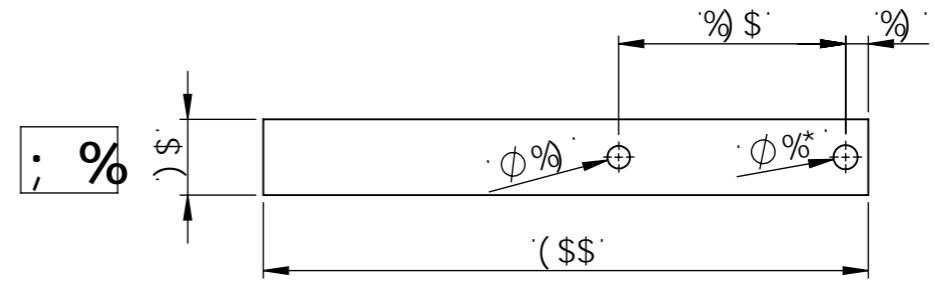

Bš	8fgl[ bUh]cb	@b[ i Yi f	E hf
: %	: Yf'd'Uh) \$ l' % \$	( \\$ \$	%
: &	hi VY' Wuff' ( \$ l' (	+ \\$ \$	%
9Wfci	9Wfci 'A % ( 'Vfi h		&
; ')	f h f f' fcbX' « %*	) \$	%
; ci d]Y' f d]b[ 'Y' X' f l' Y' ž' % l' + \$' « (	; ci d]Y' f d]b[ 'Y' X' f l' Y' ž' % l' + \$' « (		%



& ) ' l ' ( 06fi hXfii g]bU[ Y2

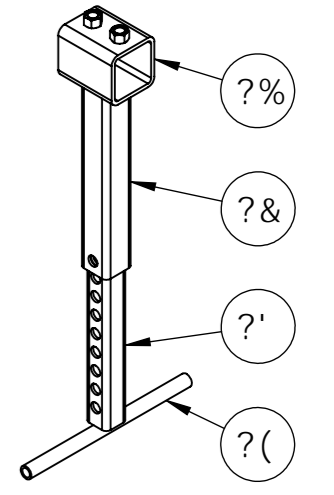
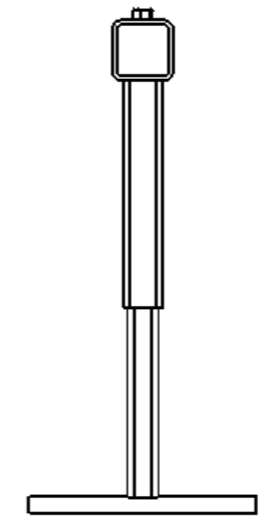
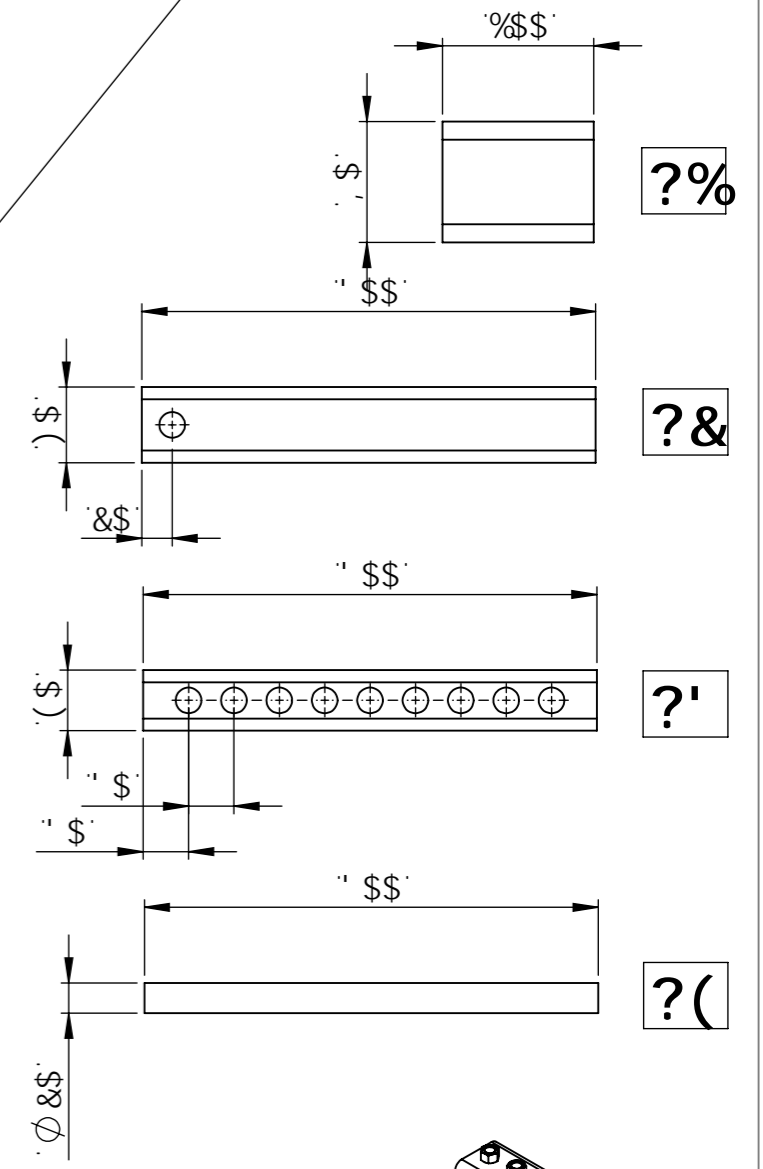
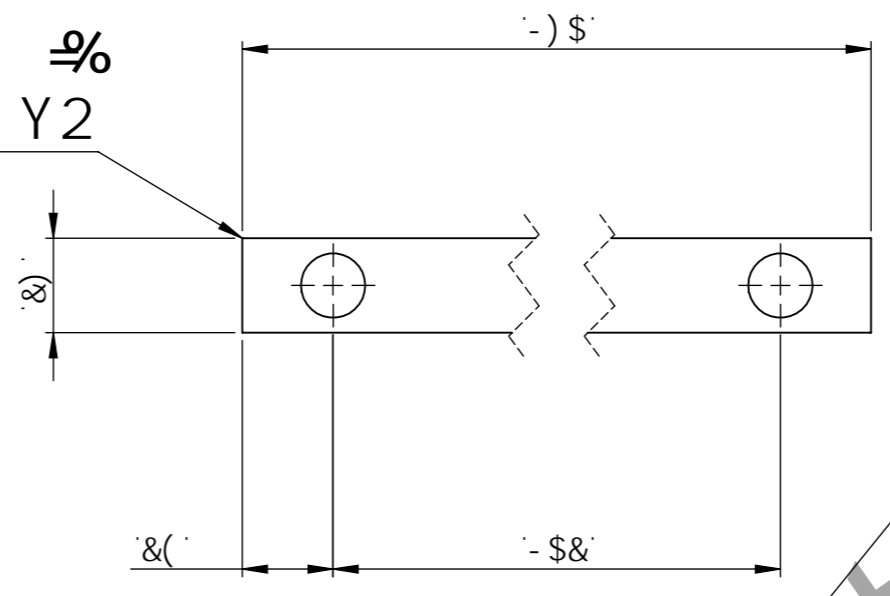
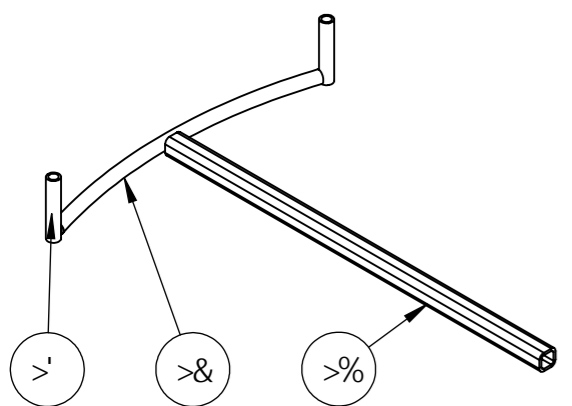
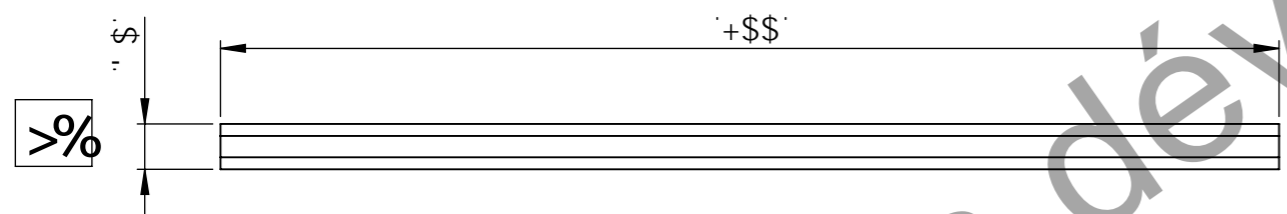
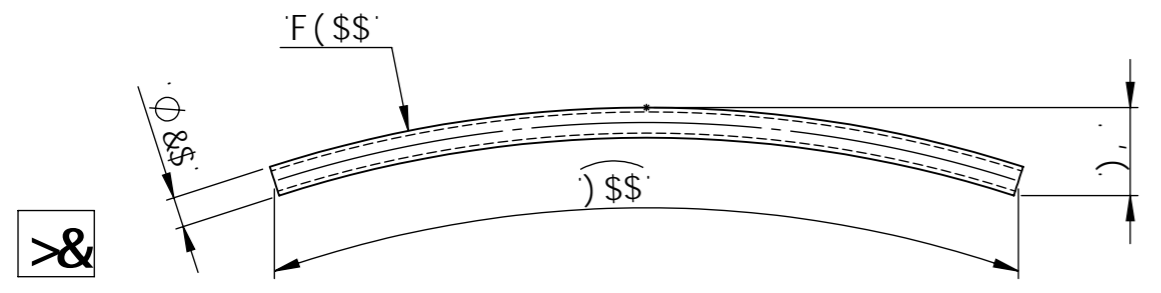
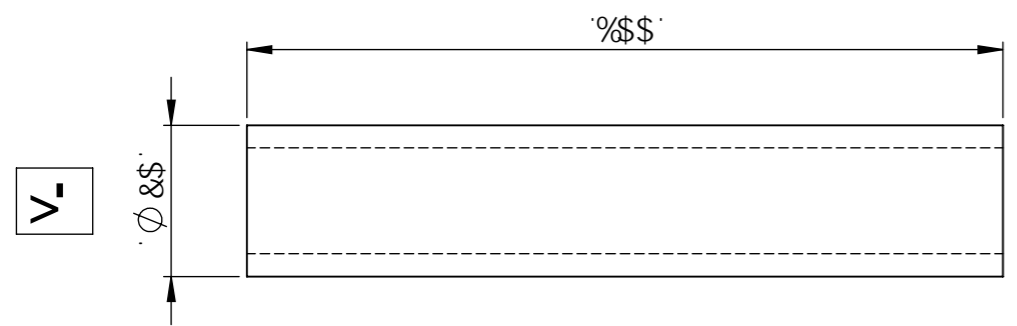

En développement

Bš	8fg] bU]cb	@b[i Yif	E hf
>%	hi VY Wuff' '\$l '(	+\&\&\&	%
>&	hi VY fcbX '&\$l ''	)\&\&\&	%
>'	hi VY fcbX '&\$l ''	\&\&\&\&	&

Bš	8fg] bU]cb	@b[i Yif	E hf
?%	hi VY Wuff' '\$l '*	\&\&\&	%
?&	hi VY Wuff' '\$l '(	'\&\&\&	%
?'	hi VY Wuff' '\$l '(	'\&\&\&	%
?(\	hi VY fcbX '&\$l ''	'\&\&\&	%
9Wfci	9Wfci 'A %(\ vfi h		&

J Yfgjcb	%"\$	E hf	%	
8 UHY	&* # \$ + # & \$ % *			
Ci h	6]bYi gY f h c]Y			
D], WY	Bca YbWUhi fY XfhU]`fY			



Bš	8fgj[ bUhc b	@b[ i Yi f	E hf
5%	hi VY`WUfff` , \$I`*`	&) \$	%
5&	hi VY`WUfff` %\$ \$I` ,	% \$	%
5'	hi VY`WUfff` , \$I`*`	%&\$ \$	%
9Wfci	9Wfci`A`%(`Vfi`h`		-
6%	hi VY`WUfff`*)`I`*`	%\$ \$ \$	%
gY[ YSW j YHY	G], [ Y`W`j`YHY		%
7 Uj U`Yf`6DC	7 Uj U`Yf`6DC		&
7%	fVUi`WXY`hi`Vi`U]fY`«`]bh`'`%	(\$	(
8%	fVUi`WXY`hi`Vi`U]fY`«`]bh`'`%	+\$	&
8&	hi VY`WUfff` ) \$I`(`	' ) \$	&
8'	:Yfd`Uh) \$I`%\$	' \$ \$	&
9%	hi VY`WUfff`(\$I`(`	' ) \$	&
9&	:Yfd`Uh) \$I`%\$	%* \$	&
9'	:Yfd`Uh) \$I`%\$	&) \$	&
9(	:Yfd`Uh) \$I`%\$	&) \$	&
:%	f h f f`fcbX`«`'`\$	% \$	&
; ci d]`YSY`Ug]`ei`Y	; ci d]`Y`f`Ug]`ei`Y` ) \$I`(`	(	(
<%	hi VY`fcbX`%&I`&	%&\$	(
fci`YSUi`[`YSV]`bYi`gY	Fci`Y`Yb`h`Y`«`Yi`h`&\$`«`Ui`Y`\$		&
; %	:Yfd`Uh) \$I`%\$	(\$ \$	%
; &	hi VY`WUfff`(\$I`(`	+\$ \$	%
%	:Yfd`Uh)&`I`(`	-) \$	&
>%	hi VY`WUfff`'`\$I`(`	+\$ \$	%
>&	hi VY`fcbX`&\$I`'`	) \$ \$	%
>'	hi VY`fcbX`&\$I`'`	%\$ \$	&
J ]g<`YI`U[`cb`U`Y	J ]g<`YI`U[`cb`U`Y`A`%(`I`'`\$		,
?%	hi VY`WUfff` , \$I`*`	%\$ \$	%
?&	hi VY`WUfff` ) \$I`(`	' \$ \$	%
?'	hi VY`WUfff`(\$I`(`	' \$ \$	%
?(`	hi VY`fcbX`&\$I`'`	' \$ \$	%
; ci d]`Y`fd]`b[`Y`X`fU]`Y`ž`%`I`+\$`«`(`	; ci d]`Y`fd]`b[`Y`X`fU]`Y`ž`%`I`+\$`«`(`		,
FcbXY`Y	FcbXY`Y`«`%`g`f]`Y`@	)	)
D%	f h f f`fcbX`«`%*	' &\$	)
8(	f h f f`fcbX`«`%*	) \$	&

Bš	8fgj[ bUhc b	@b[ i Yi f	E hf
; '	f h f f`fcbX`«`%*	) \$	%
9Wfci	9Wfci`A`&(`N]b[`i`f`		*
h[`Y`Z]`Y`h`Y`«`&\$	H[`Y`Z]`Y`h`Y`A`&(`I`'`) \$		&
J ]g<`YI`U[`cb`U`Y	J ]g<`YI`U[`cb`U`Y`A`%(`I`'`) &\$		%
9Wfci	9Wfci`A`%`Ui`h`c`Z]`b]`f`		%

