

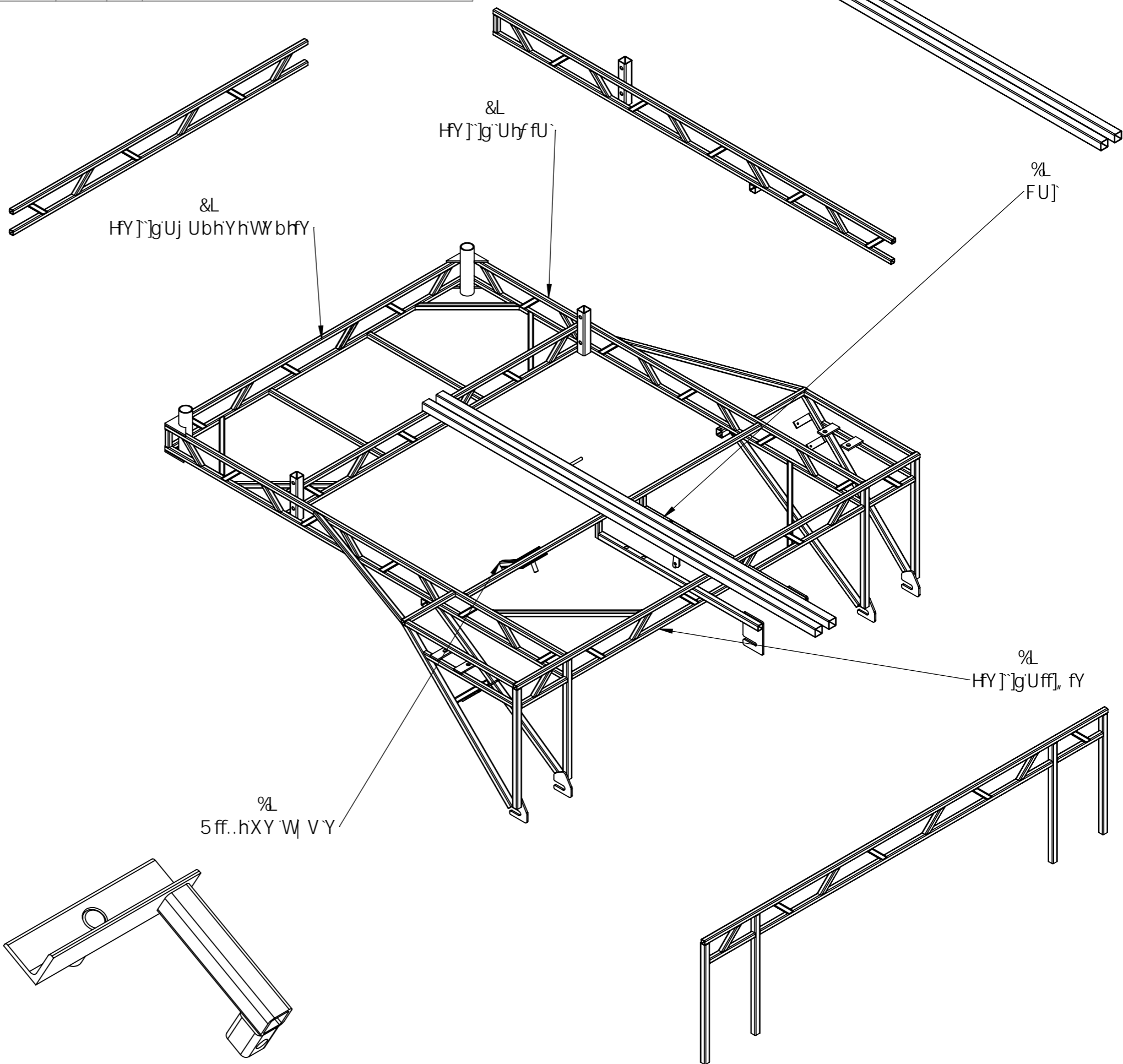

Fonds Européen Agricole pour la Développement Rural



Bš	8fgll bUHjcb	@cb[i Yi f	E hf
5''	D'UHjby X'fYWhjcb' \Ui hf		&
5' (D'UHjby X'fYWhjcb' VUggY		&
5')	hi VY'fhff' fcbX' (\$I''	%*\$	&
5%	H VY'WUff' %* 'I' &	%* &(&
5&	H VY'WUff' %* 'I' &	%* &\$	&
5'	H VY'WUff' %* 'I' &	- ,	('
5(H VY'WUff' %* 'I' &),	&
5)	H VY'WUff' &\$'I' &	(&\$	(
5*	H VY'WUff' %* 'I' &	%&\$	(
5+	H VY'WUff' %* 'I' &	%* (&	%
5,	H VY'WUff' %* 'I' &	%% &	%
5-	H VY'WUff' %* 'I' &	%)	&
5%\$	H VY'WUff' %* 'I' &	(((\$	&
5%%	H VY'WUff' %* 'I' &	&\$)	&
5%&	H VY'WUff' %* 'I' &)- ,	&
5%	H VY'WUff' &\$'I' &	*%)	&
5%(H VY'WUff' &\$'I' &	*&+	&
5%)	H VY'WUff' ' \$'I' &	%*\$	&
5%-	H VY'WUff' %* 'I' &	(' \$	&
5&'	D'UHjby Zci fWY		(
5&)	hi VY'WUff' &'I' &	' \$	&
5&+	H VY'WUff' %* 'I' &	%&\$	%
5&,	7 cfb], fY &'I' &'I''	%\$	%
5&-	H VY'WUff' %* 'I' &	, \$	%
5' \$	H VY'WUff' %* 'I' &	&\$	%
h[Y ZYhfY	h[Y ZYhfY A %&	')	%
5%*	H VY'WUff' %* 'I' &	' *)	&
5&&	D'UHjby a chYi f		&
5&\$	H VY'WUff' &\$'I' &	*) \$	&
5&%	H VY'WUff' %* 'I' &),	&
5&*	: Yfd'Uh' \$'I')	*\$	(
5&(hi VY'WUff' ' \$'I' &	%\$	&
5' %	H VY'WUff' %* 'I' &	' \$\$	(
5' &	H VY'WUff' %* 'I' &	(* \$	&
5' *	H VY'WUff' &\$'I' &	%&\$	%
5' +	H VY'WUff' %* 'I' &	-)	%
5' ,	: Yfd'Uh&\$'I' (+	(
5' -	H VY'WUff' %* 'I' &	% \$	%
J]g<YIU[cbUY	J]g\YIU[cbUY A , 'I') \$		%
5(\$: Yfd'Uh&'I' (%&\$	%



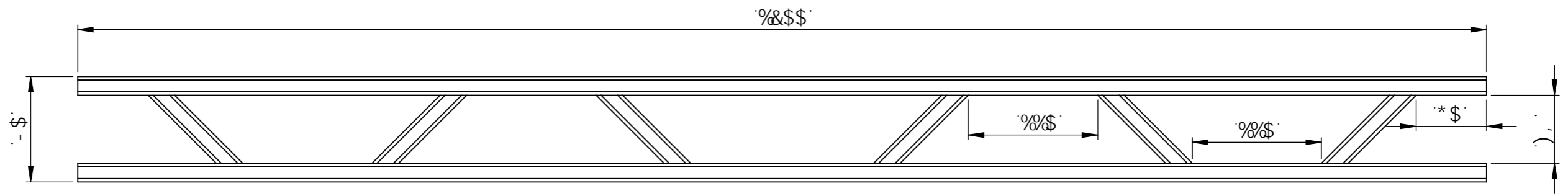
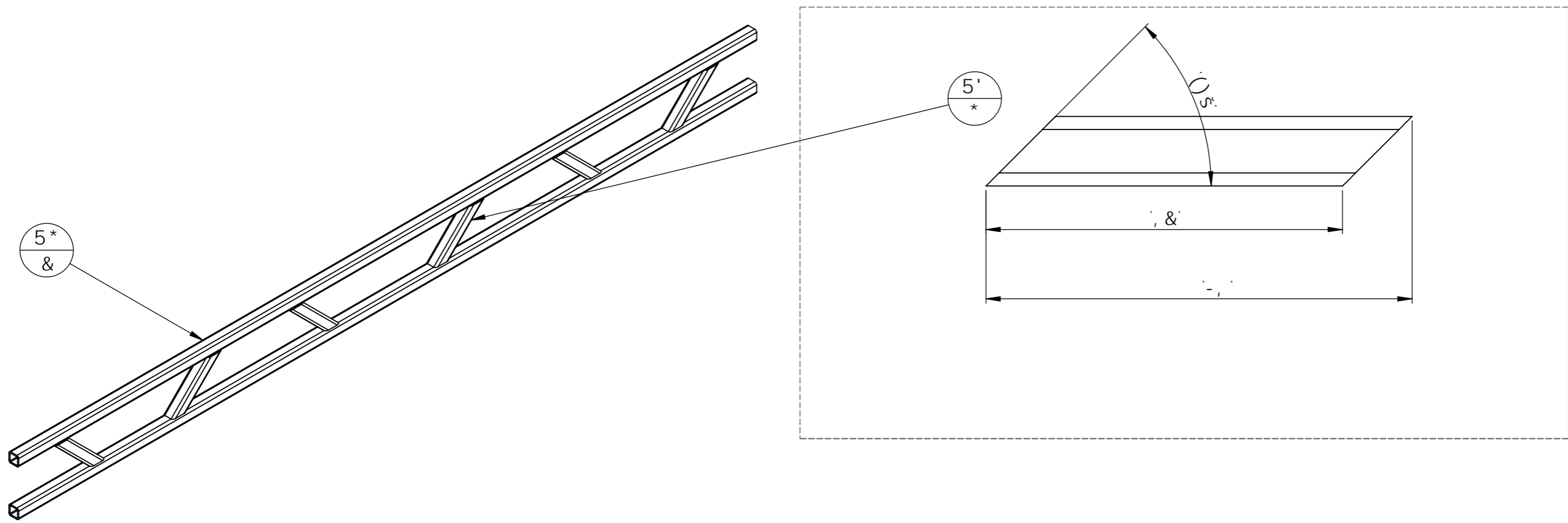

Bš	8fgl[bUhcb	@b[i Yi f	E hf
5'	H VY 'Wff' %' l' &	- ,	*
5*	H VY 'Wff' %' l' &	%&\$\$	&

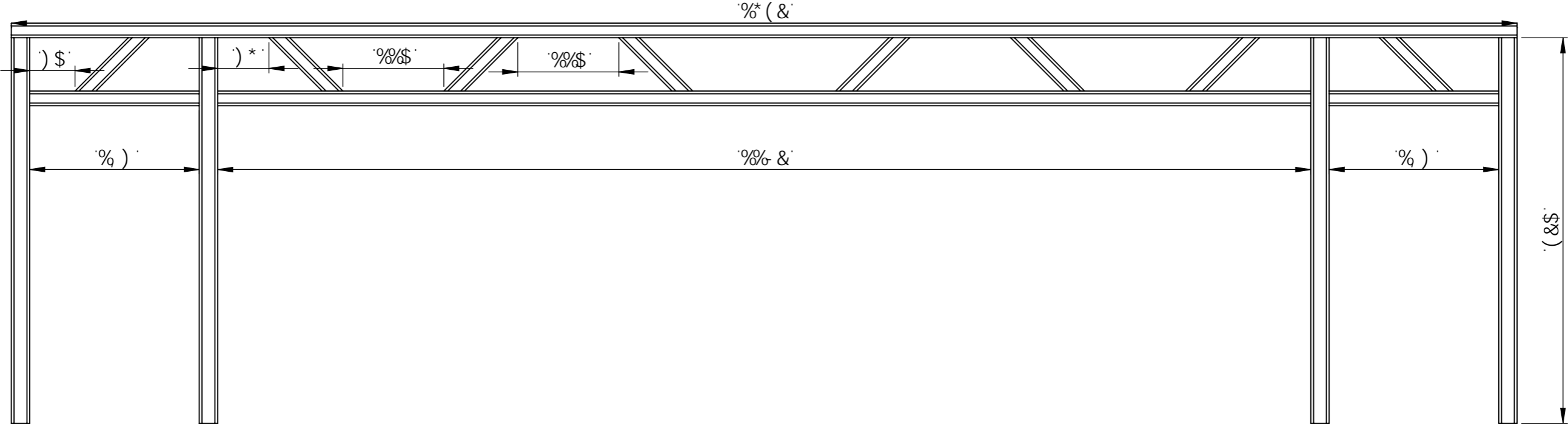
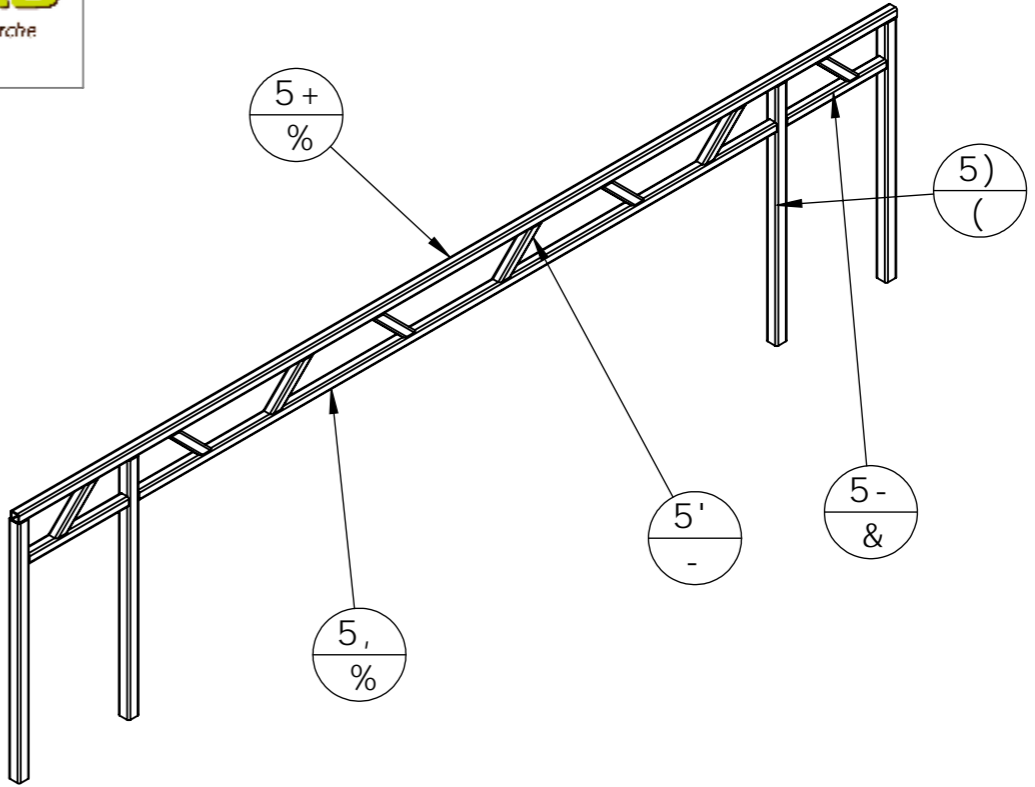

Bš	8fgl[bUhc b	@b[i Yi f	E hf
5'	H VY 'WUff' '%* 'l' &	- ,	-
5)	H VY 'WUff' '&\$' 'l' &	(&\$	(
5+	H VY 'WUff' '%* 'l' &	%* (&	%
5,	H VY 'WUff' '%* 'l' &	%%&	%
5-	H VY 'WUff' '%* 'l' &	%)	&

B6: 'XfHU]gXY 'U'd], W' 5' 'XUbg'U'dU[Y'dffWfXYbhY"



Fonds Européen Agricole pour la Développement Rural
 (FSE) - Investissements pour le futur

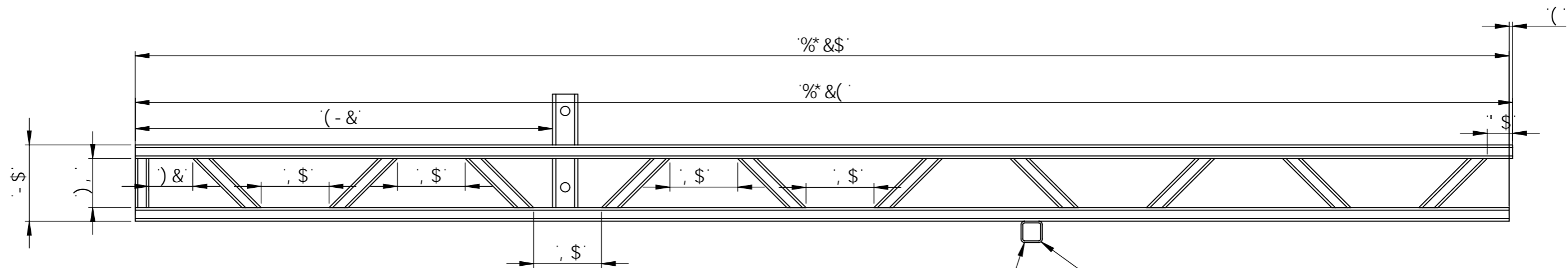
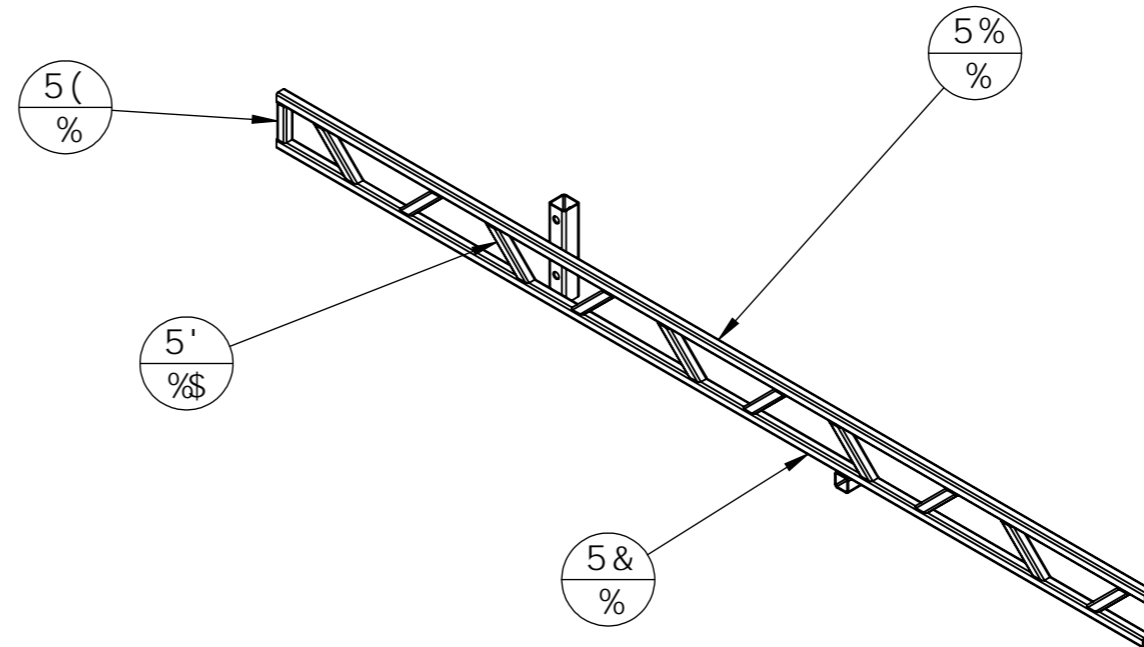
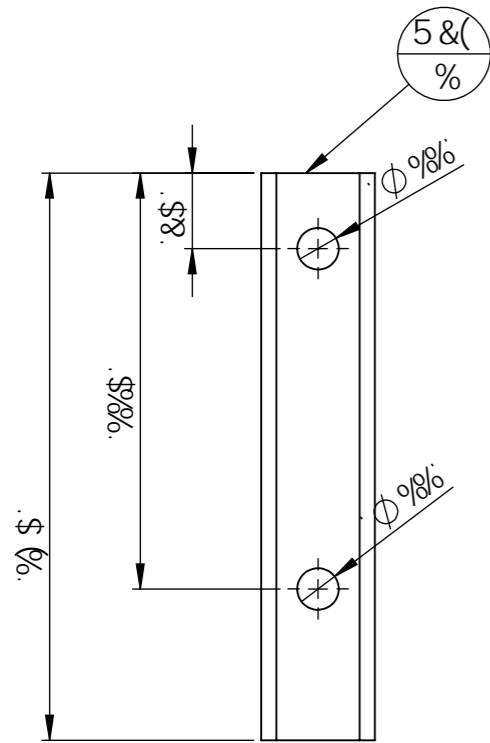

Bš	8fgl[bU]cb	@b[i Yi f	E hf
5%	H VY 'WUff' %* 'l' &	%* &(%
5&	H VY 'WUff' %* 'l' &	%* &\$	%
5'	H VY 'WUff' %* 'l' &	- ,	%\$
5(H VY 'WUff' %* 'l' &),	%
5&(hi VY 'WUff' " \$'l' &	% \$	%
5&)	hi VY 'WUff' &) 'l' &	' \$	%

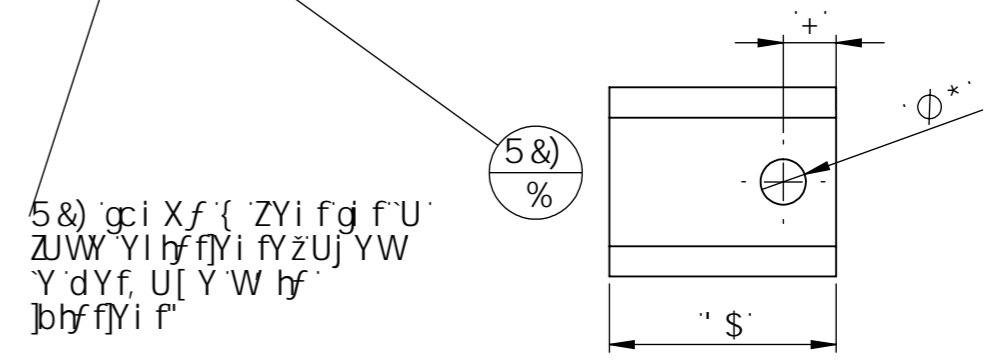

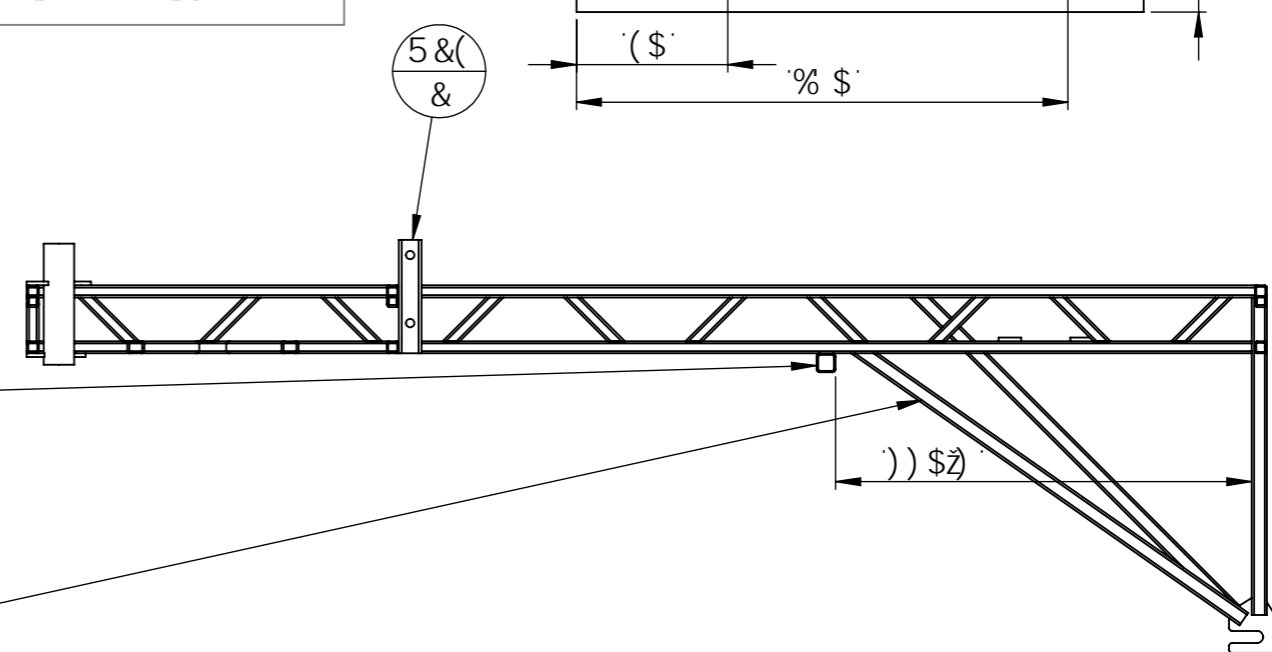
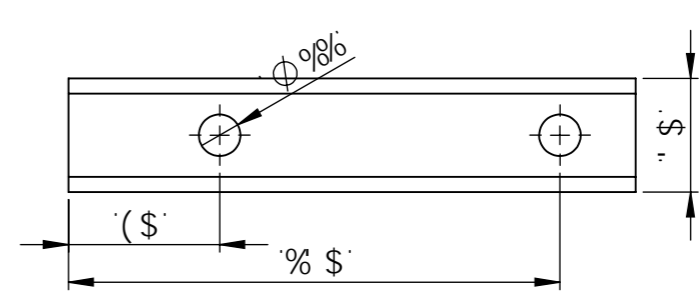
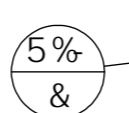
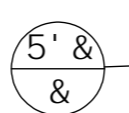
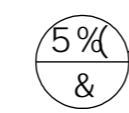
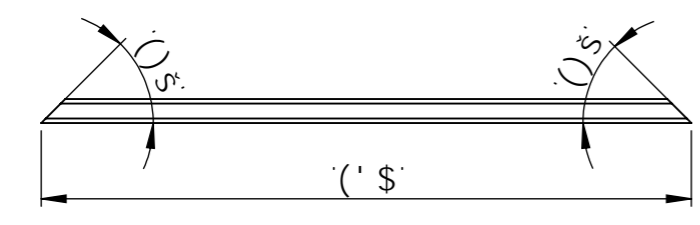
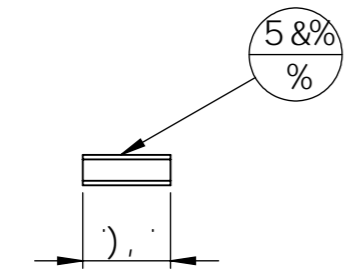
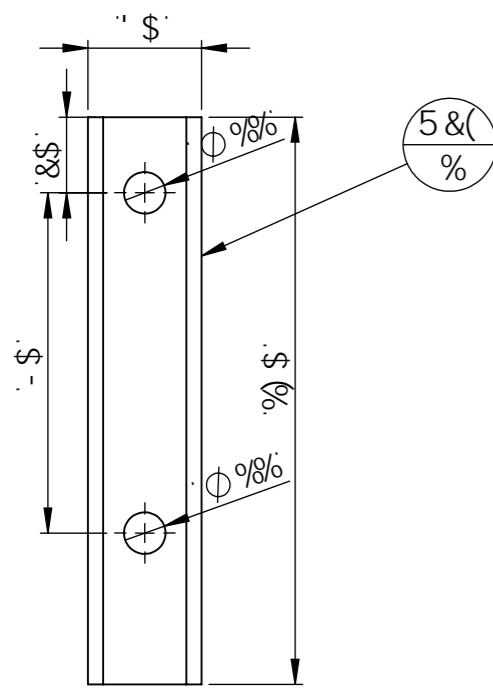
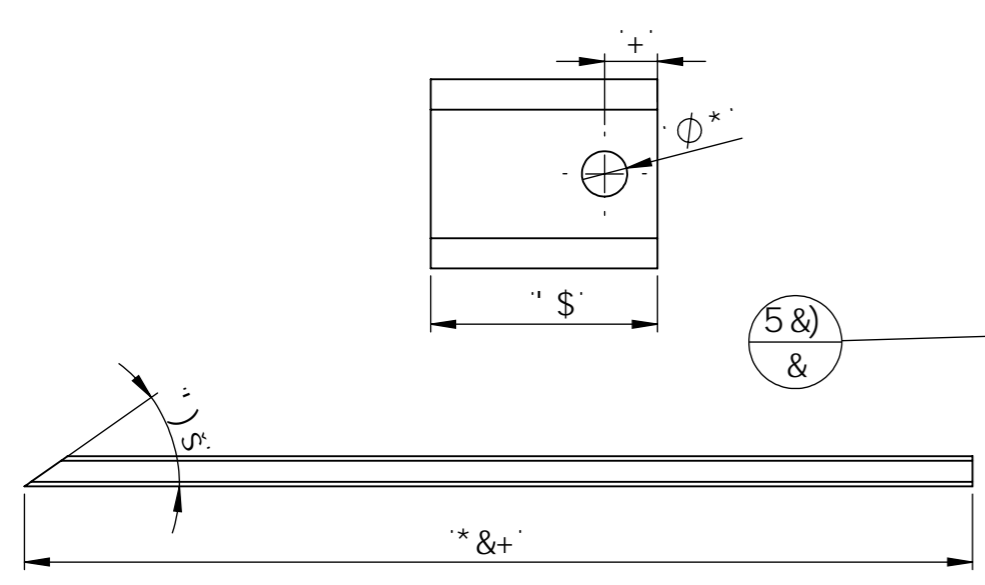

7 C I D9'8!8

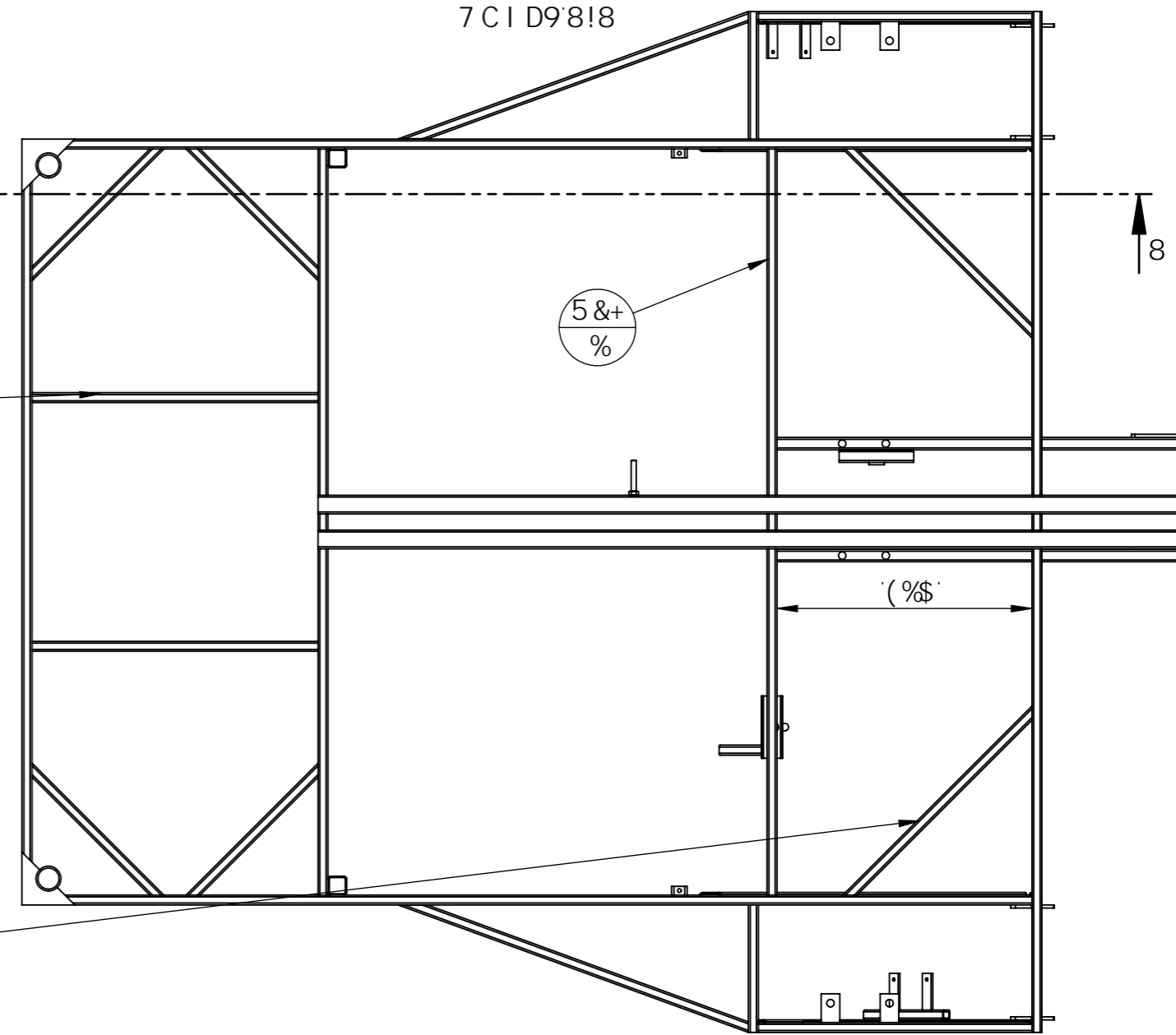

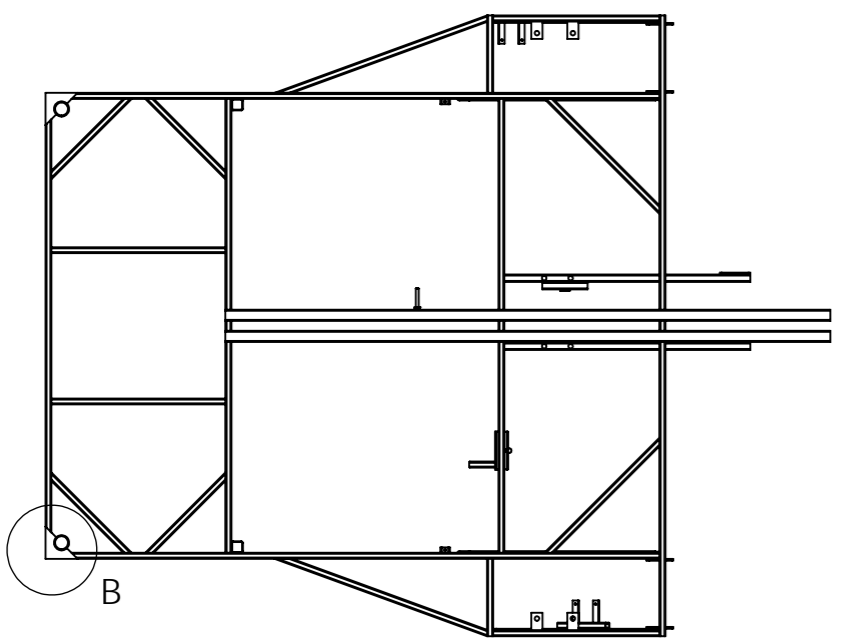

Ji Y 'XY'XYggj g

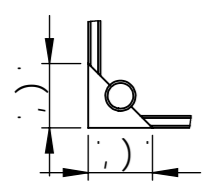

8vH5 @B
 97 < 9@9%.' %\$

Ji Y 'XY'XYggci g

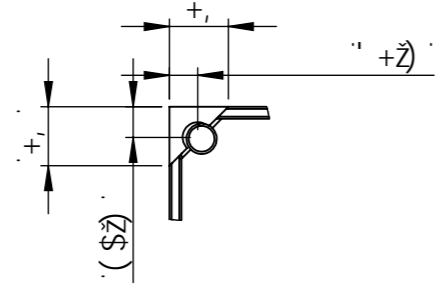

8vH5 @C
 97 < 9@9%.' %\$

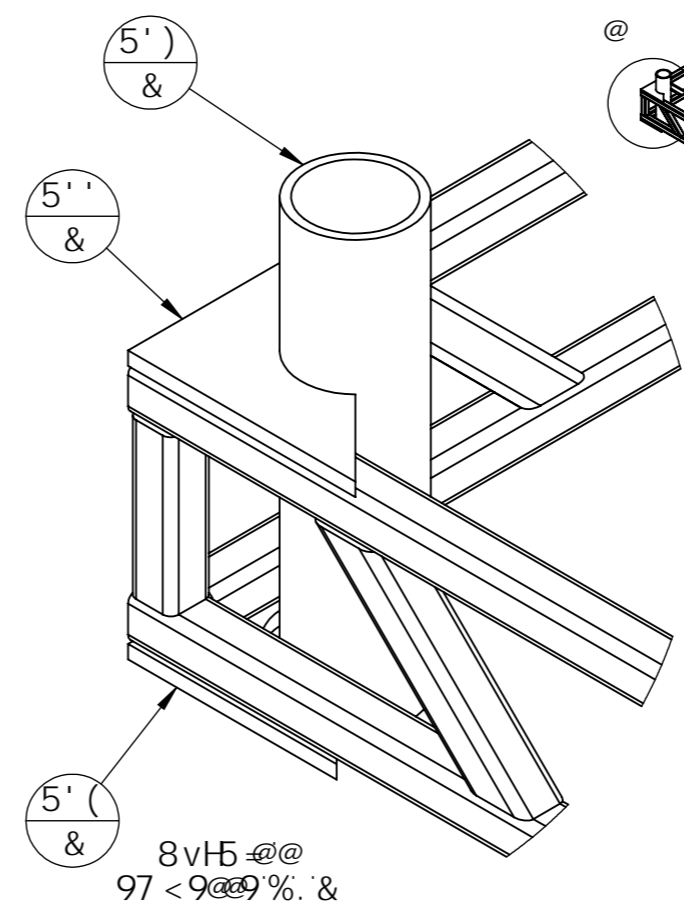

8vH5 @@
 97 < 9@9%.' &

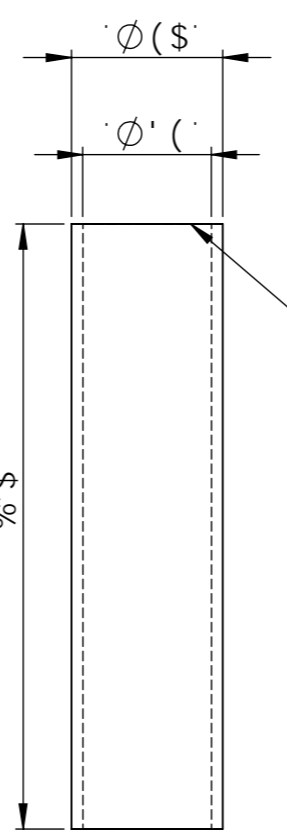

BŠ	8fgl[bUh]cb	@b[i Yi f	E hf
5')	h VY 'f h]f 'fcbX' (\$'l "	%*\$	%

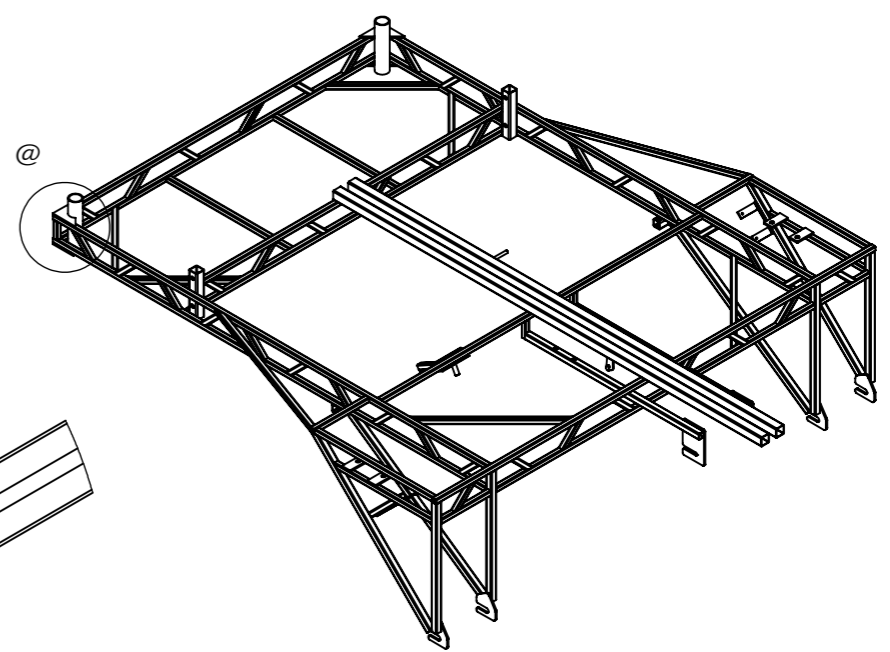

D], WgXfWci dfYg'UgYf'.

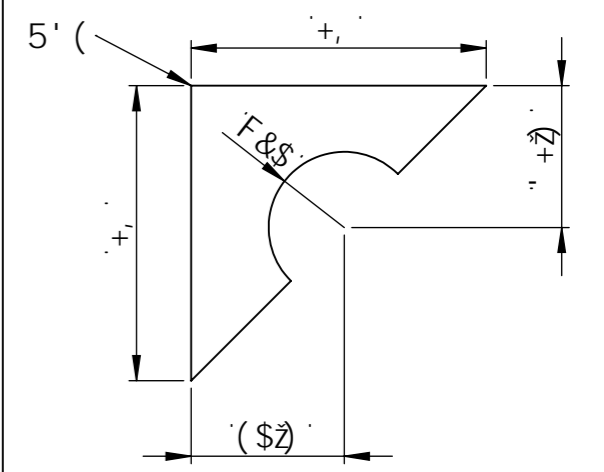
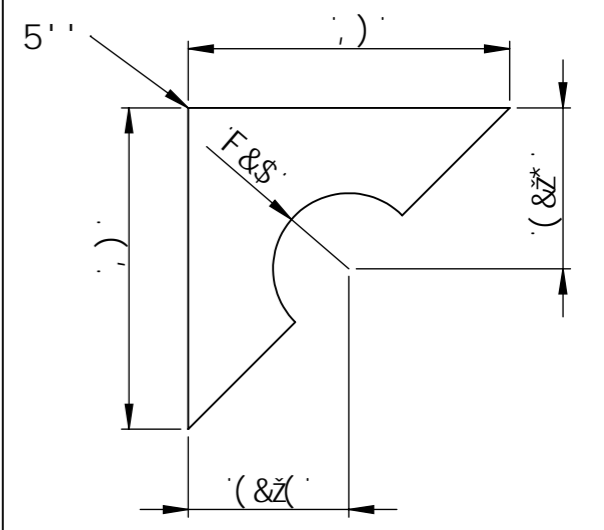

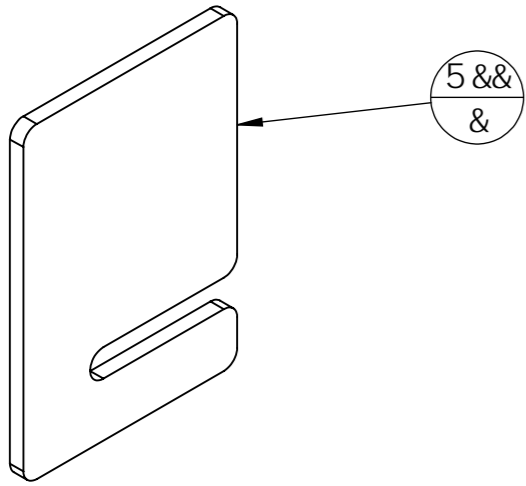

D], WŸ { 'XfWŸi dYf'
 { 'U'a Yi 'Yi gY 'XUbg'
 Xi 'Zf'd`UhXY`&) :

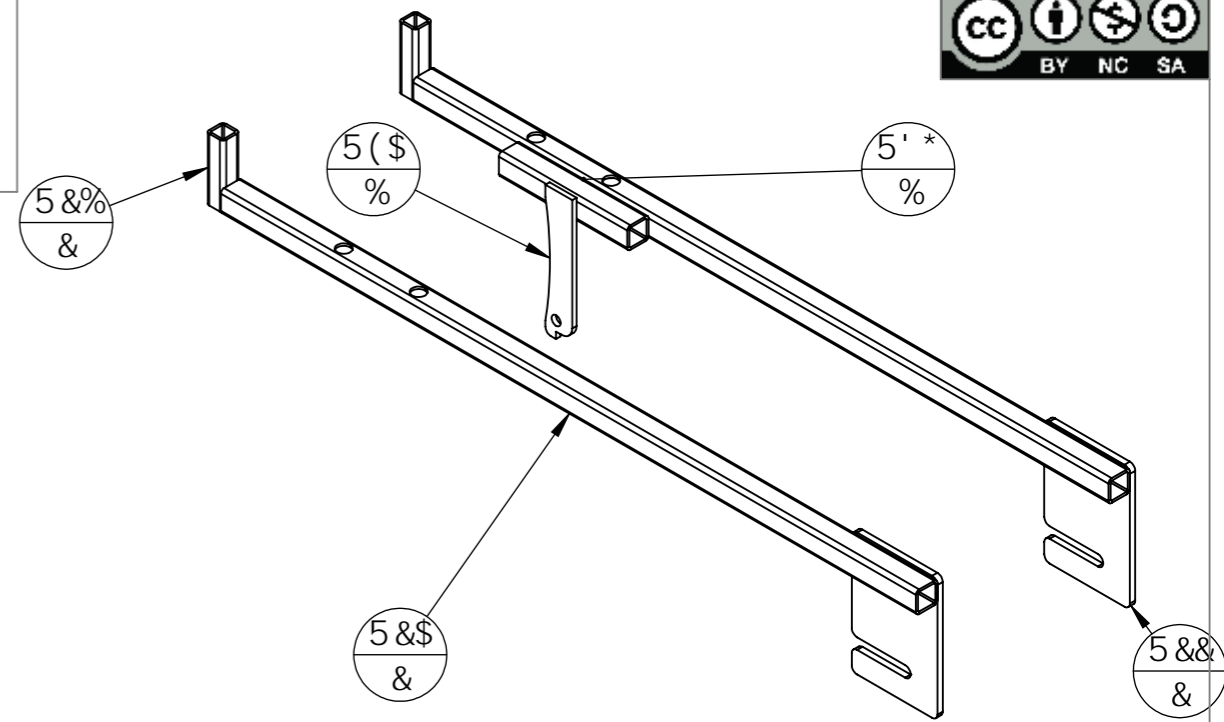

D], WŸg5&&'XfWŸi dYf'UgYf'.

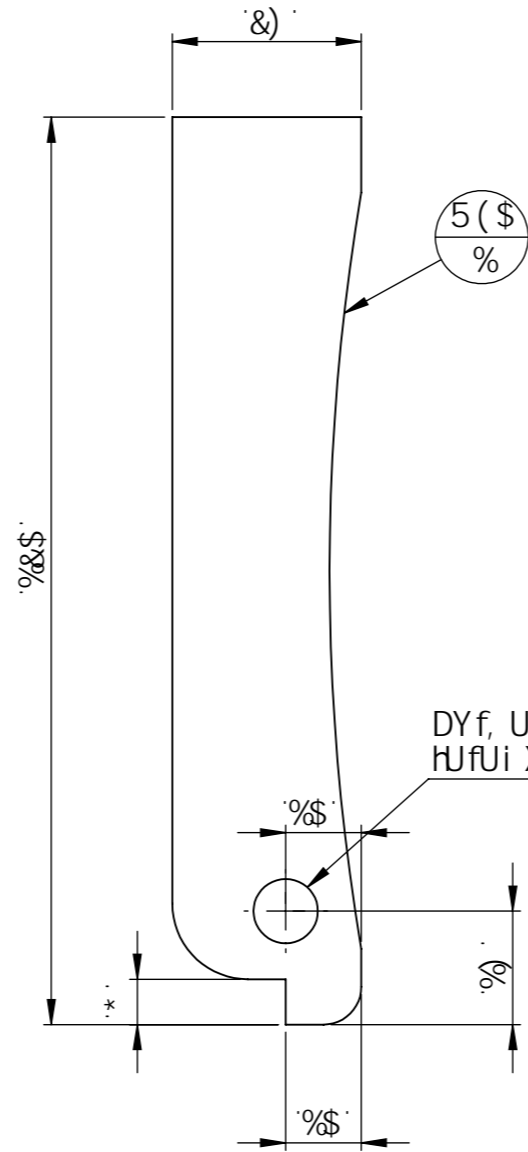
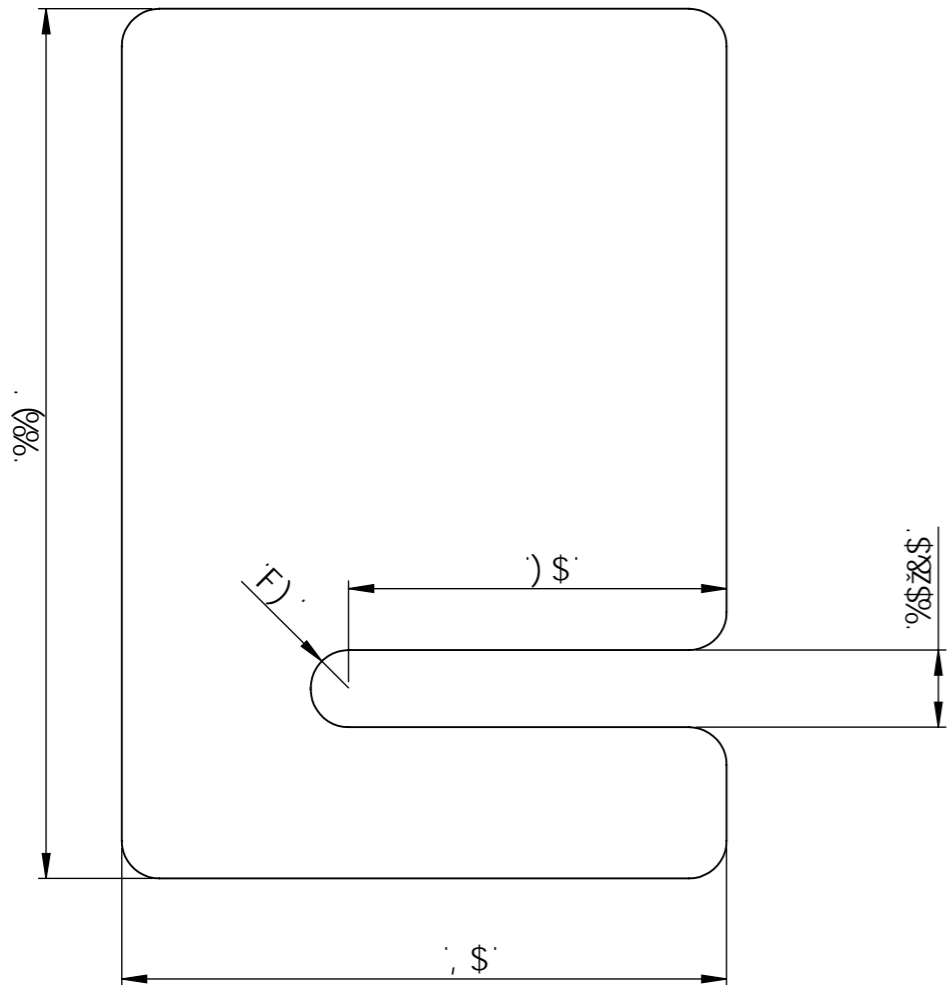

DYf, U[Y{ ; ')' dci f'
 HJfui XU[Y'A %\$

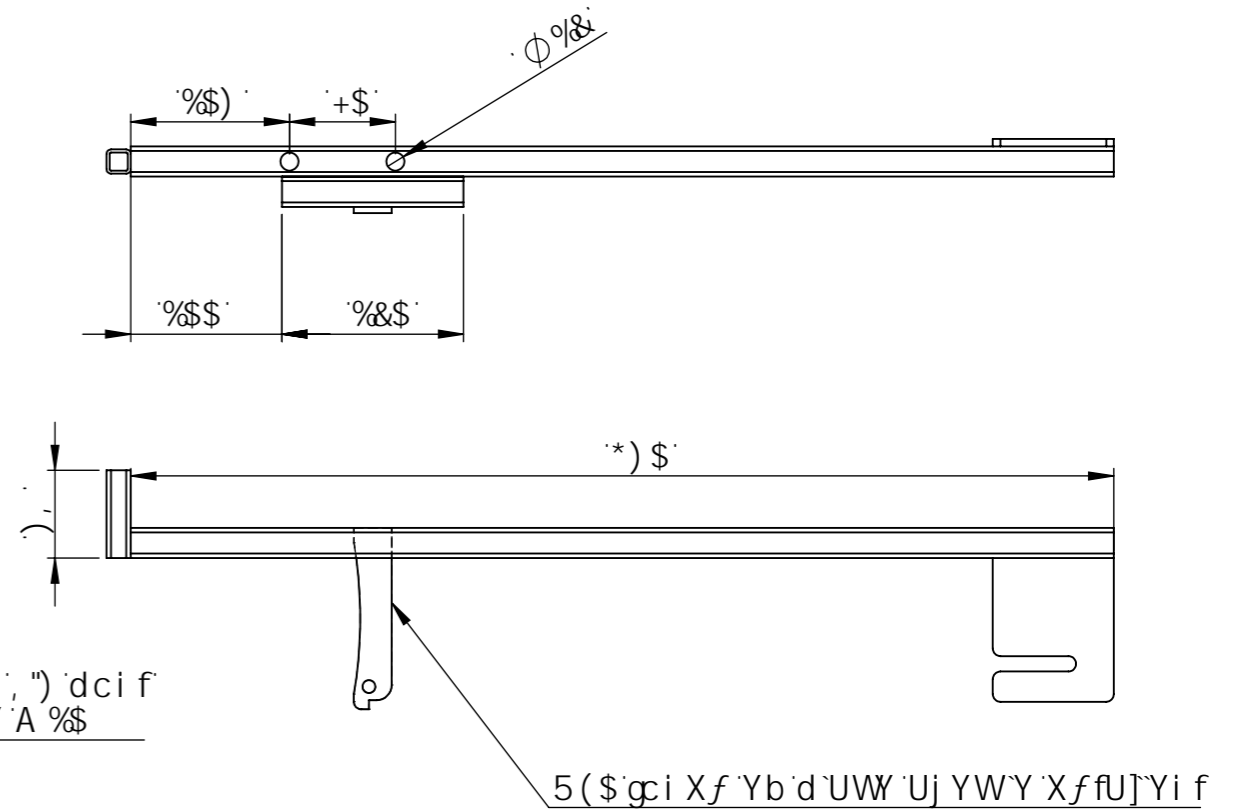

5 (\$'gci Xf'Yb'd`UW`Uj YWY`XfWŸ]Yi f

Bš	8fg[bUħcb	@b[iYi f	E hf
5 &&	D'UhŸbY'a chYi f		&
5 &\$	H VY`Wuff`&\$'l`&	*) \$	&
5 &%	H VY`Wuff`%'l`&) ,	&
5' *	H VY`Wuff`&\$'l`&	%&\$	%
5 (\$: Yf'd`Uh&) 'l` (%&\$	%



Fonds Européen Agricole pour la Développement Rural (FEDER)

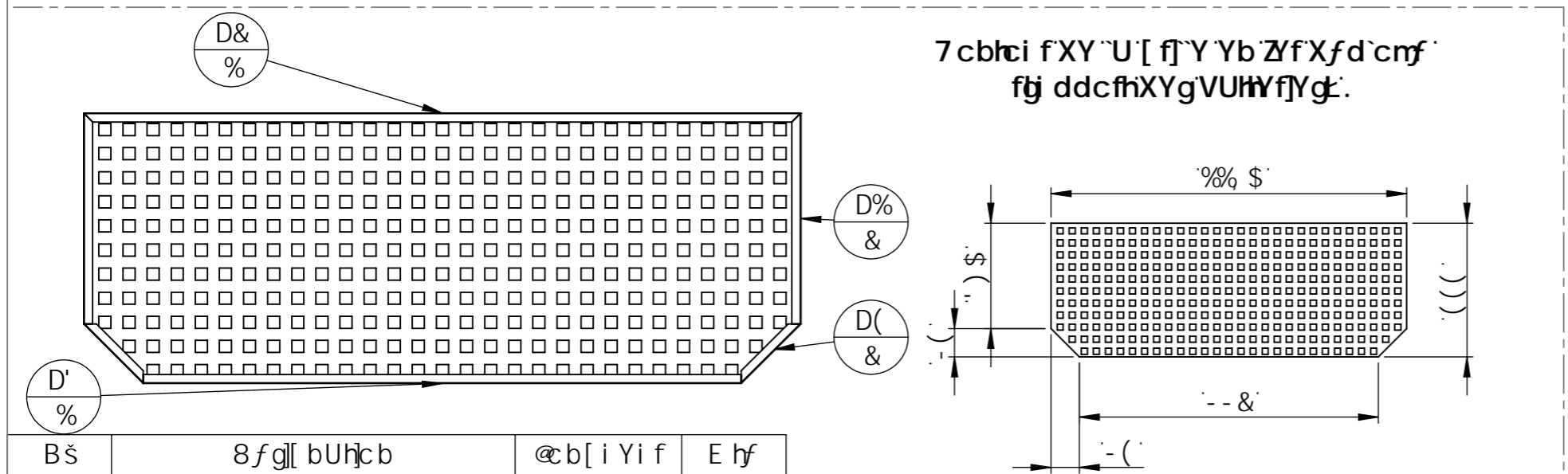
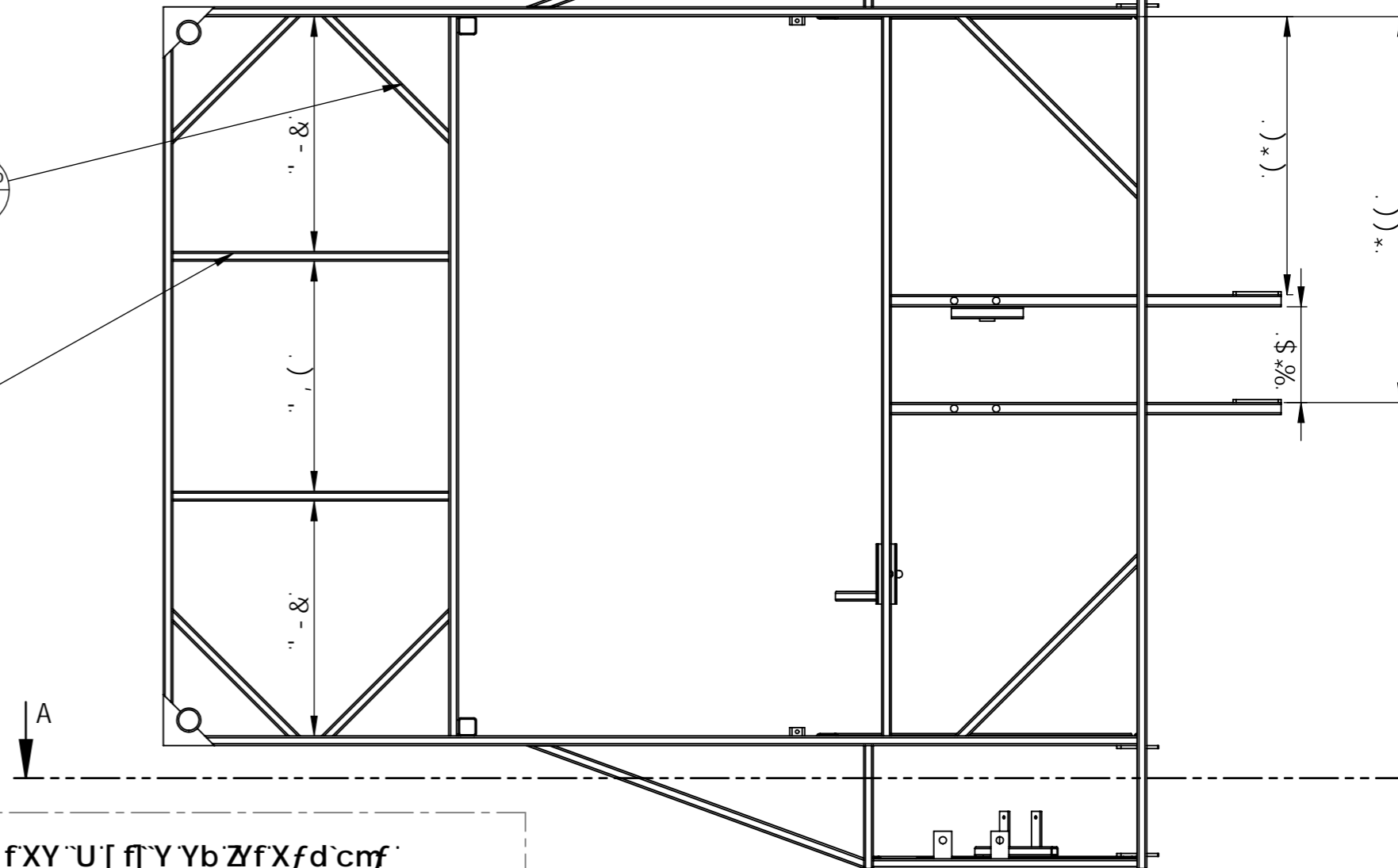
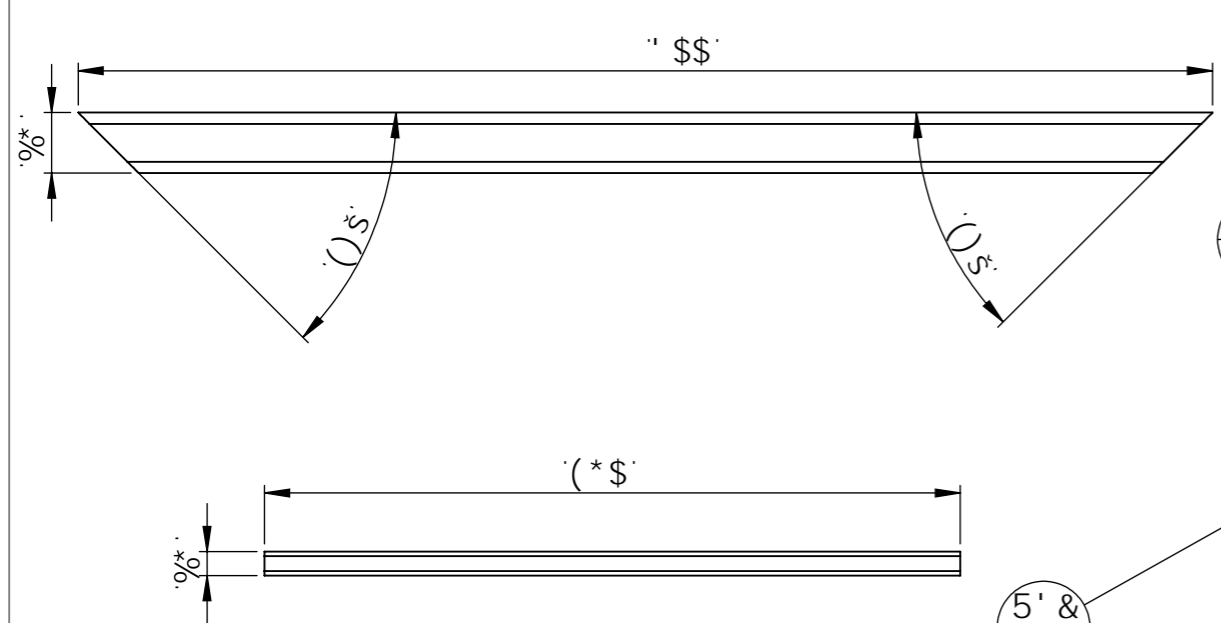

7 cblci fXY`U [f]`Y`Yb`Zf`Xfd`cmf`
 fgj ddcfhXYgVUHf]Yg.

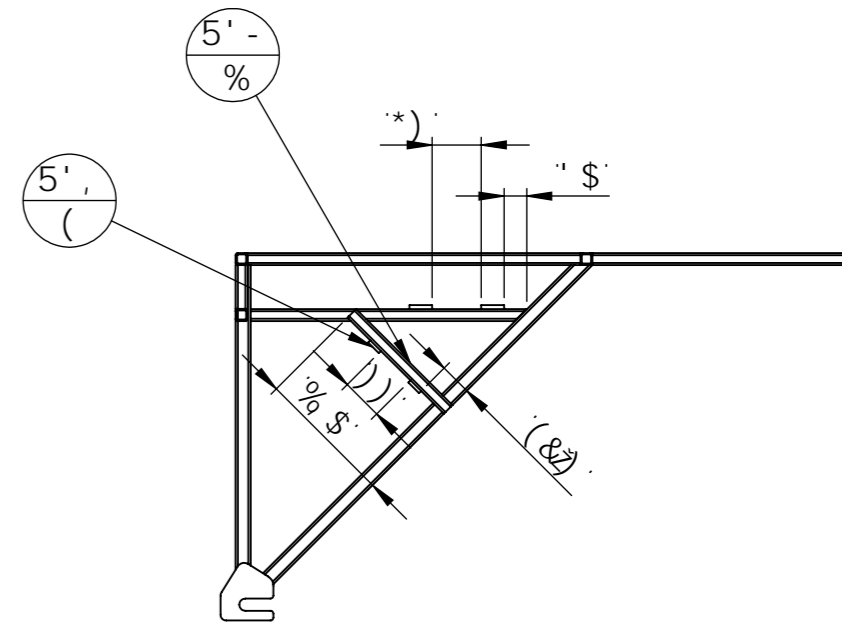

7 C I D9'A !A
 97 < 9@@@ % . % \$

Bš	8fg[bUH]cb	@b[iYif	E hf
D%	I`D5: %`I`%`I`%`	') \$	&
D&	I`D5: %`I`%`I`%`	%\$- \$	%
D'	I`D5: %`I`%`I`%`	, - &	%
D(I`D5: %`I`%`I`%`	% \$	&
D)	: YfXfd`cmf`		%

Bš	8fgl[bUhcb	@b[iYif	E hf
5 &	7 cfb], fY &) l' &) l' "	%%\$	%
5 &-	H VY 'WUff %* l' &	, \$	%
5' \$	H VY 'WUff %* l' &	&\$	%
H[Y Z]YhfY	h[Y Z]YhfY A %&	')	%

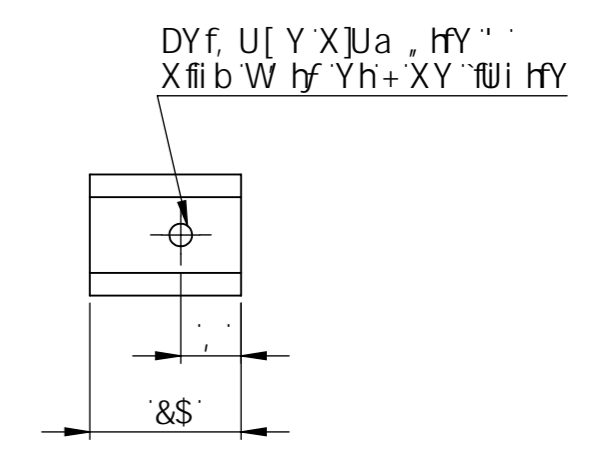
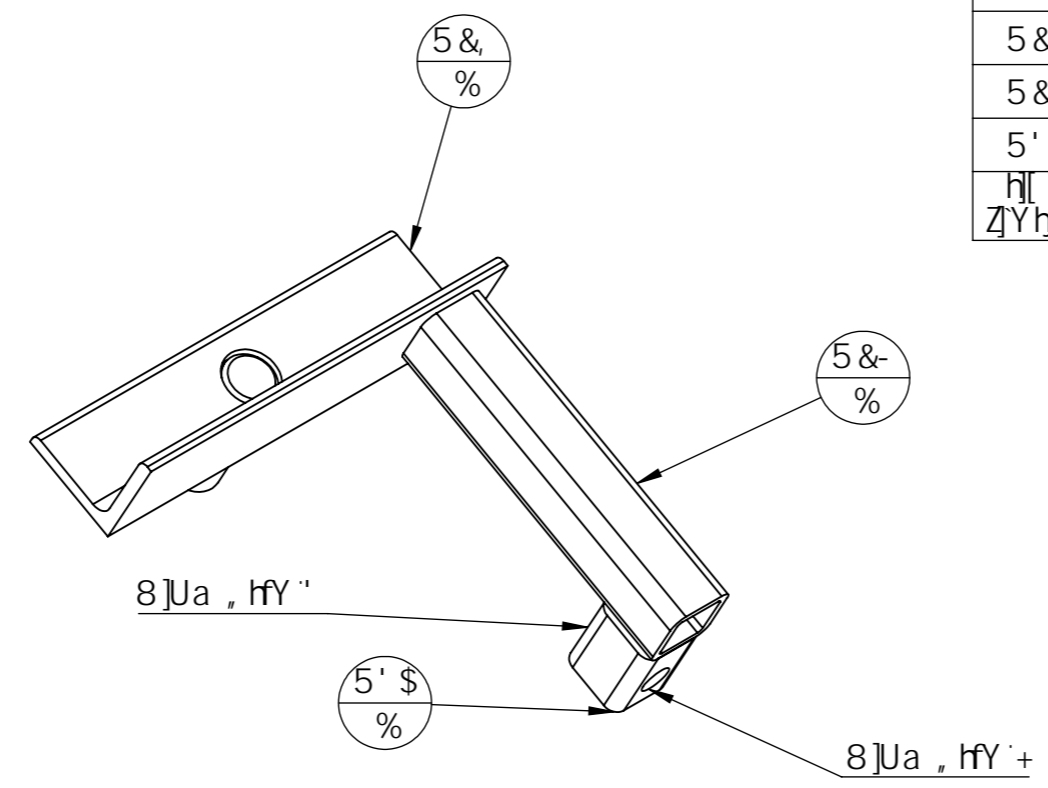

H[Y Z]YhfY :gc i XfY' XUbg
'U' Wc fb], fY' dYfWfY

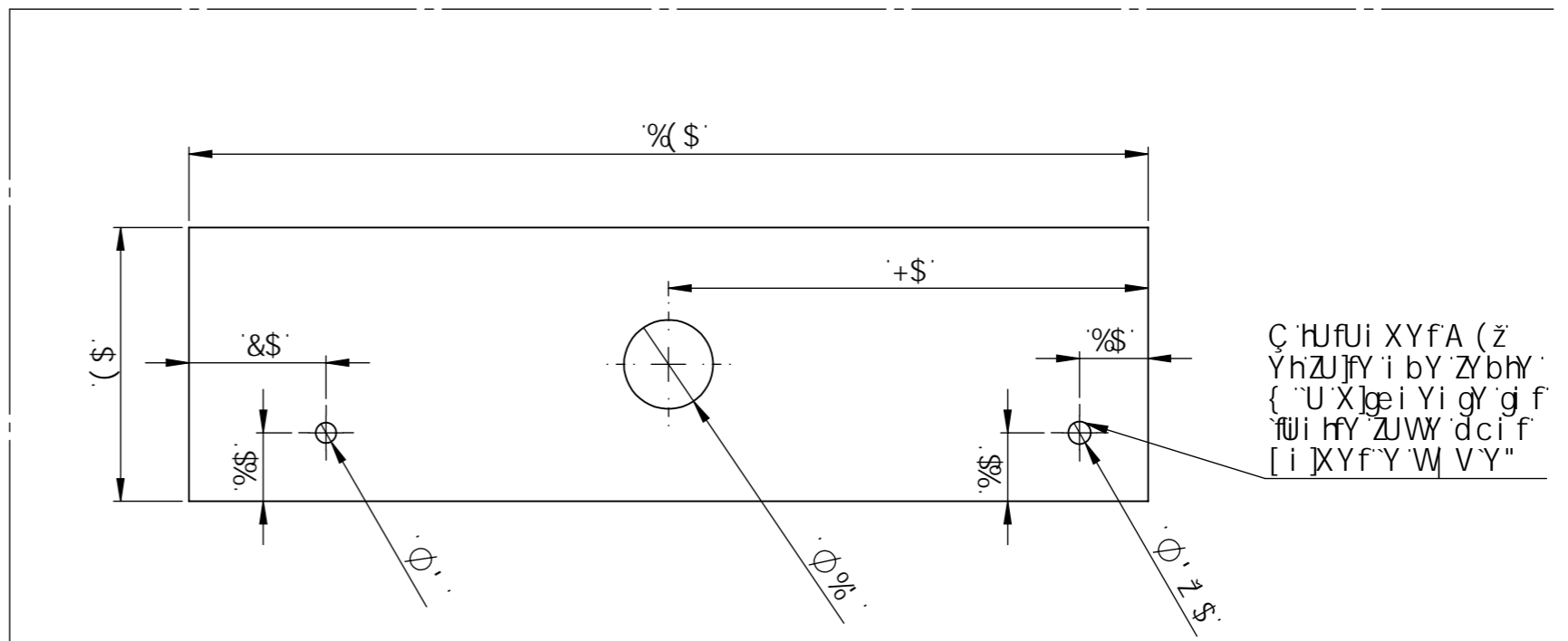
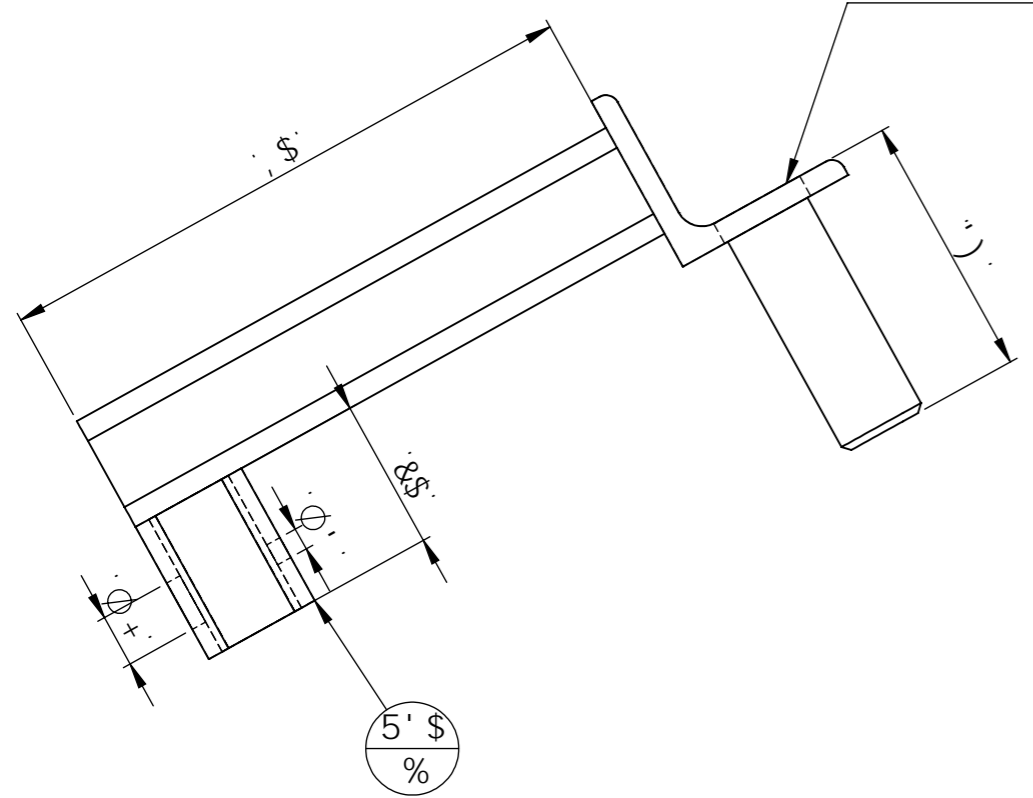

Bš	8fgl[bUhcb	@b[iYif	E hf
: %	: Yfd' Uh(\$ l')	%(\$	%

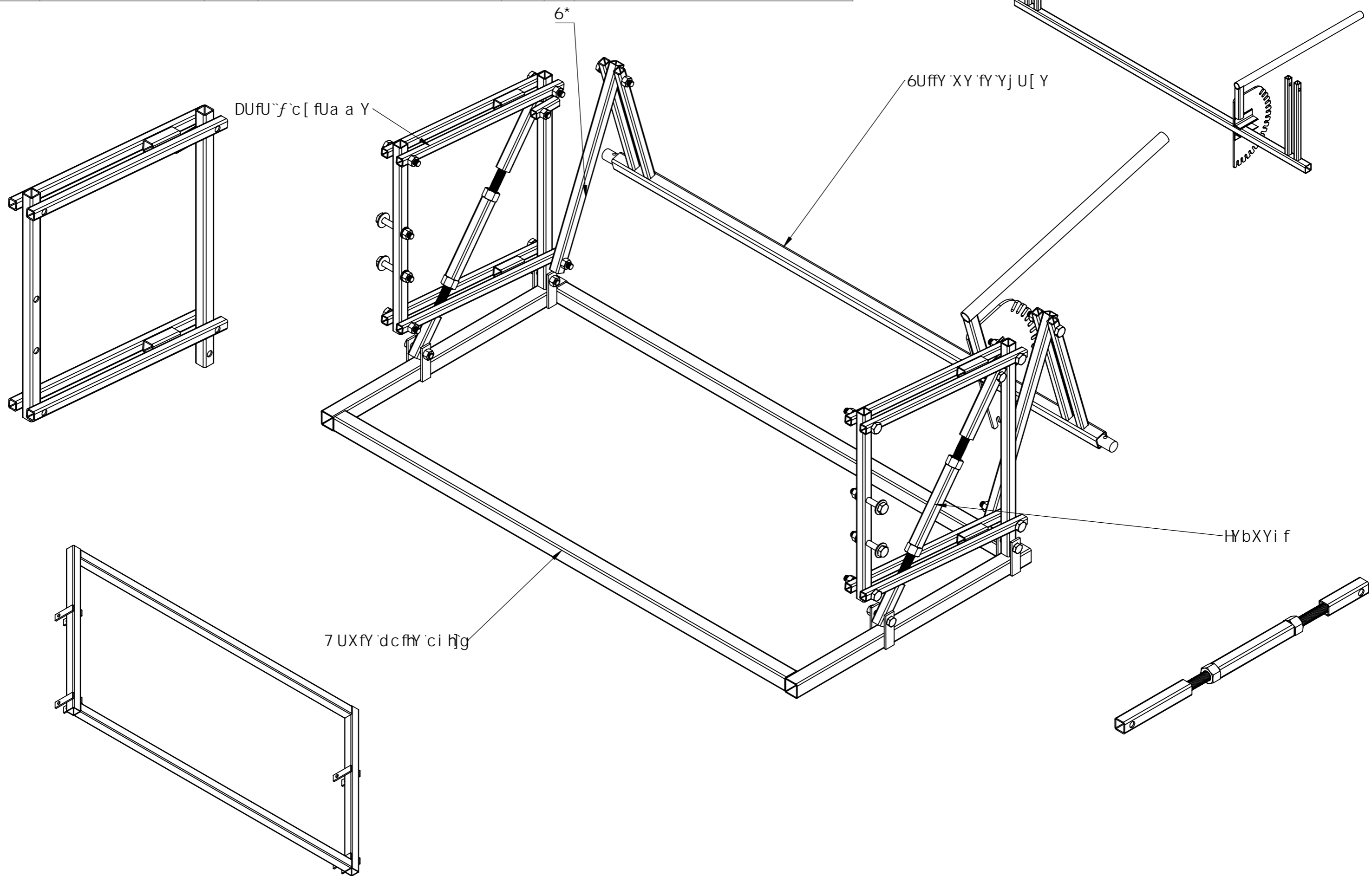

Hci g`YgUI YgicbhXYgVci `cbgA %\$
 dUfhY`Ya YbhZ`Yhf g

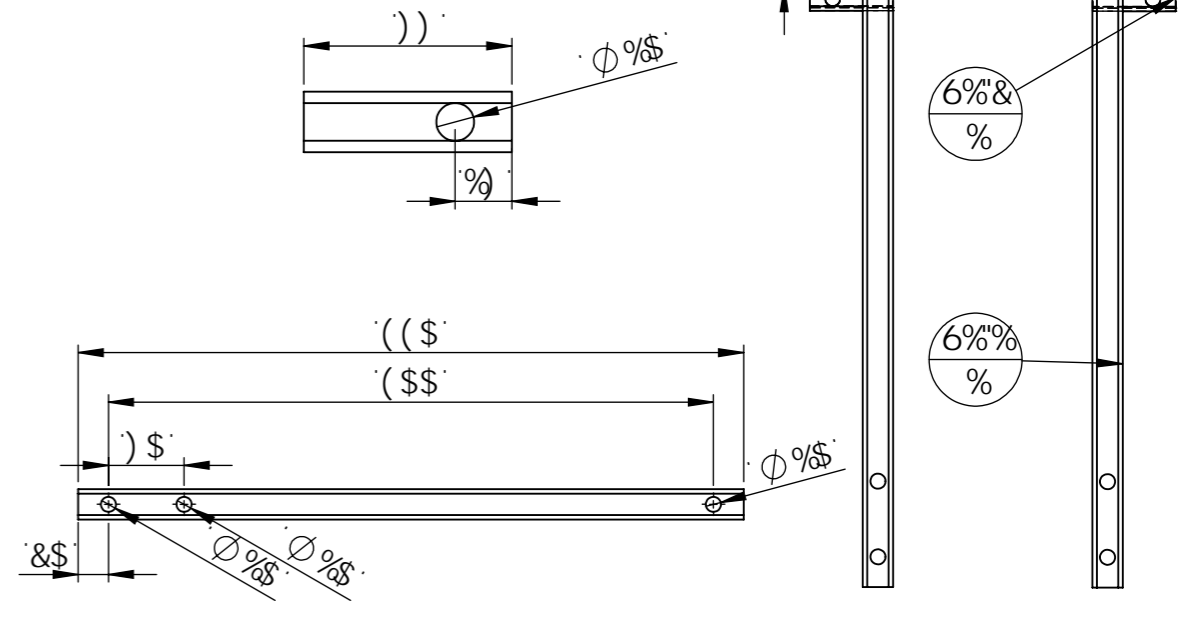
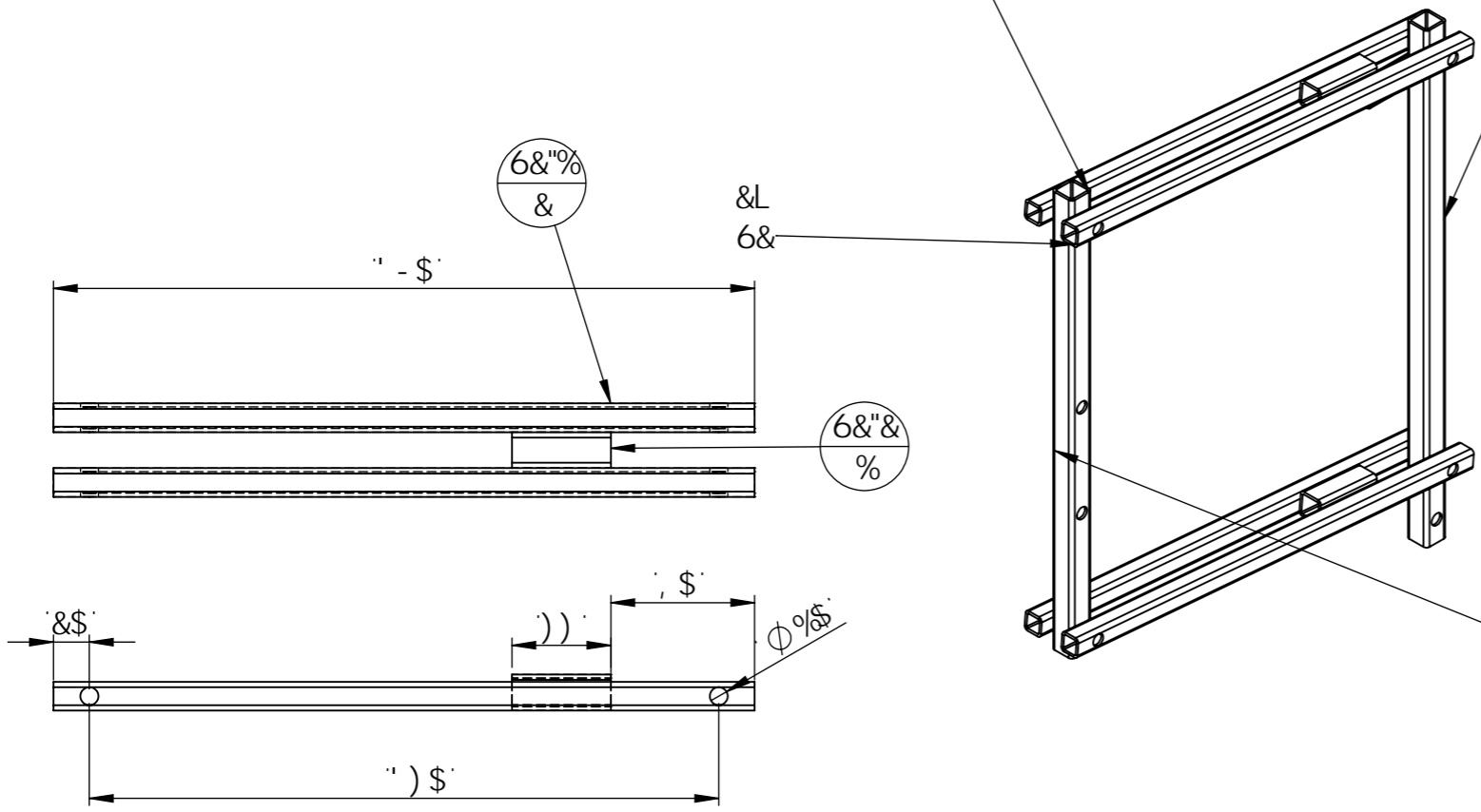

6' "%
%

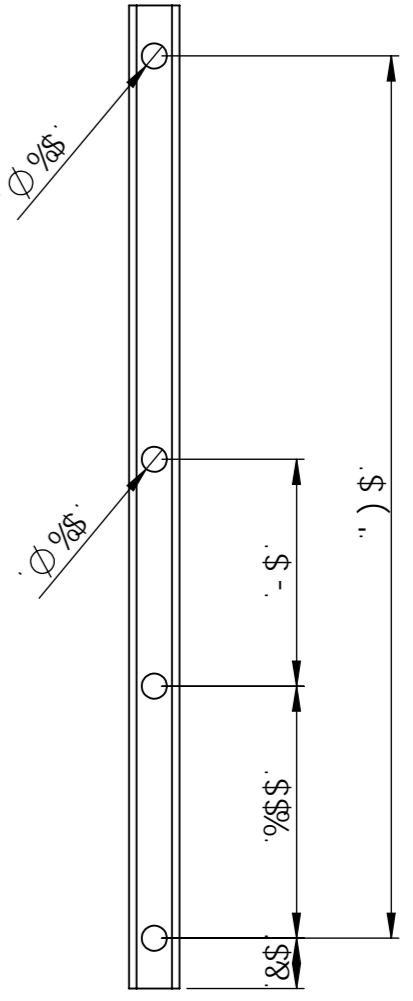

B6 : 6* Ygh]XYbhe i Y { '6&"%

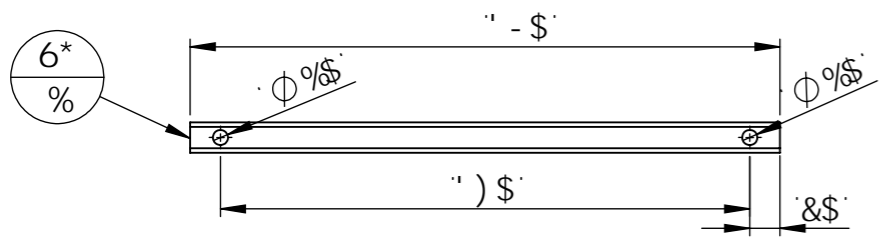

Bš	8fgl[bUh]cb	@b[i Yif	E hf
6*	H VY`WUff`&\$`I`&	'-\$	%

Bš	8fgl[bUh]cb	@b[i Yif	E hf
6' "%	H VY`WUff`&\$`I`&	'-\$	%
6%"%	H VY`WUff`&\$`I`&	(((\$	%
6%"&	H VY`WUff`%*`I`&)	%
6&"%	H VY`WUff`%*`I`&	'-\$	(
6&"&	H VY`WUff`&\$`I`&)	&

8UH Y & (#\$' #&\$%*
 J Y fgj c b %"&
 C i h j 5 [[fnci _ D], WY A cbhU[Y `dUfU`f`c[fUa a Y E hf %



Fonds Européen Agricole
 pour le Développement Rural
 (FSE) - Investissements pour le futur

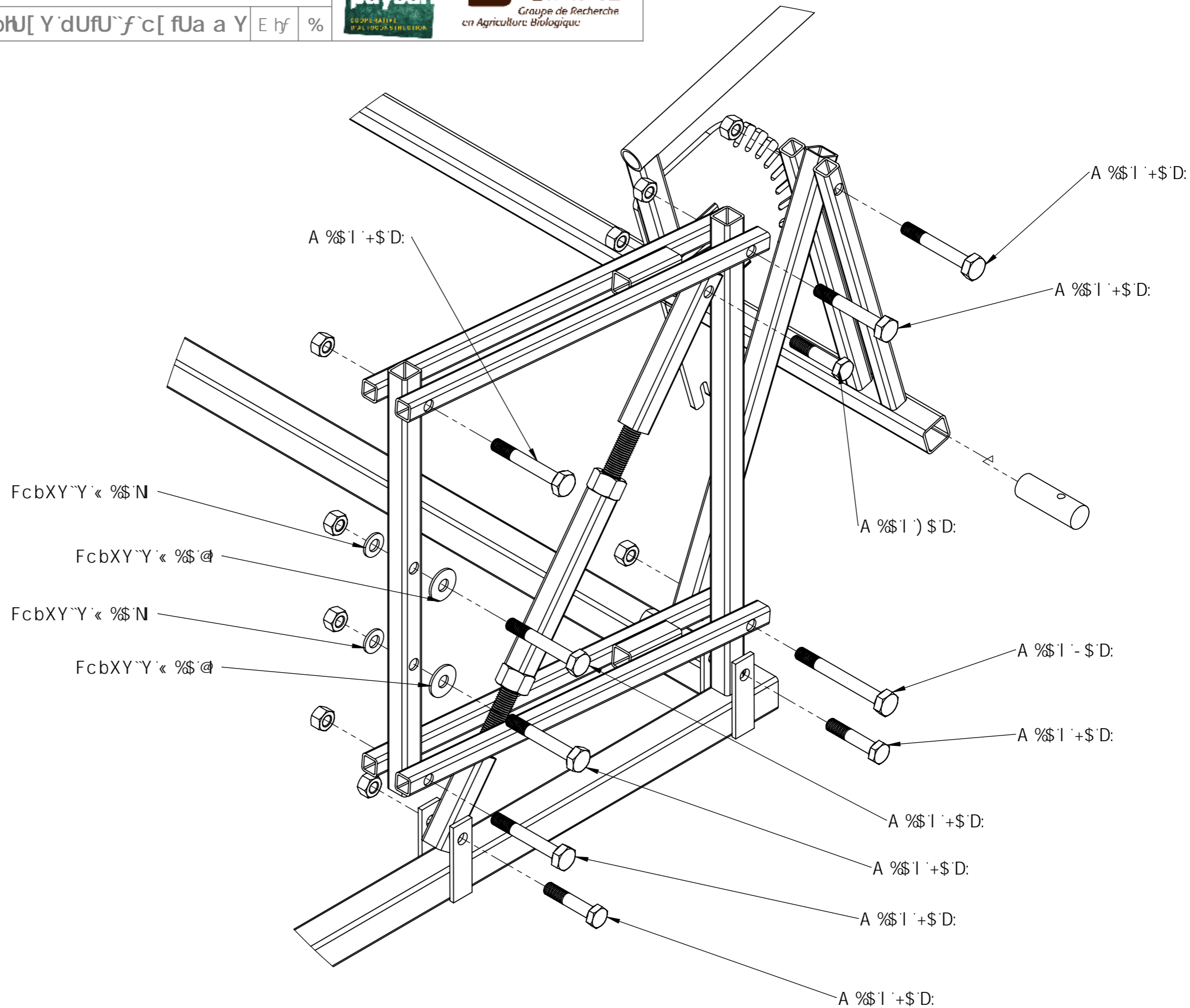

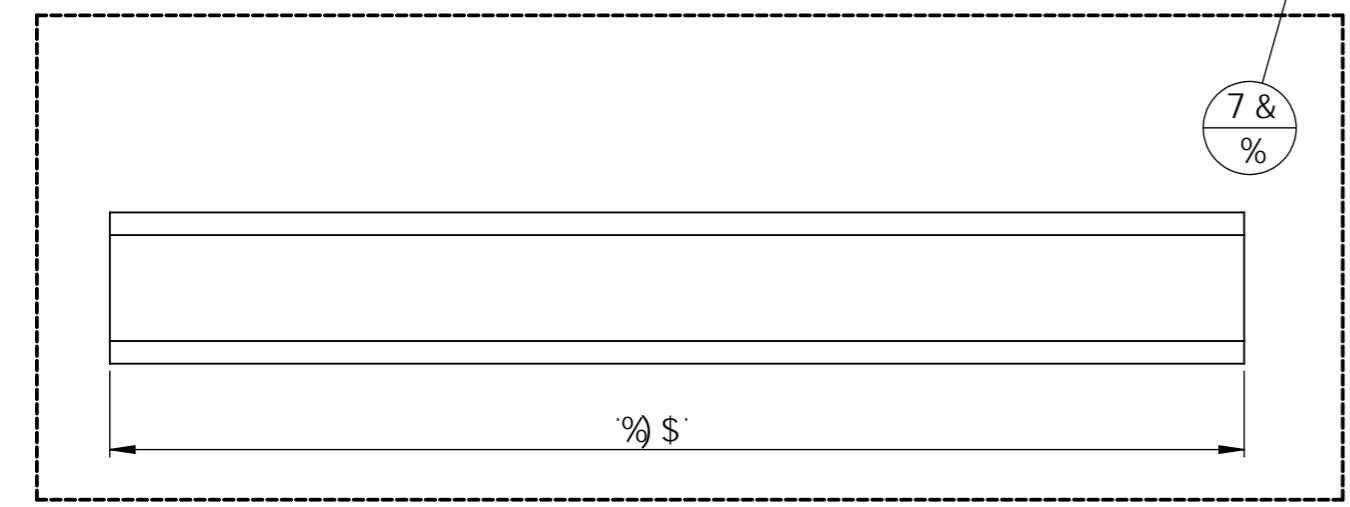
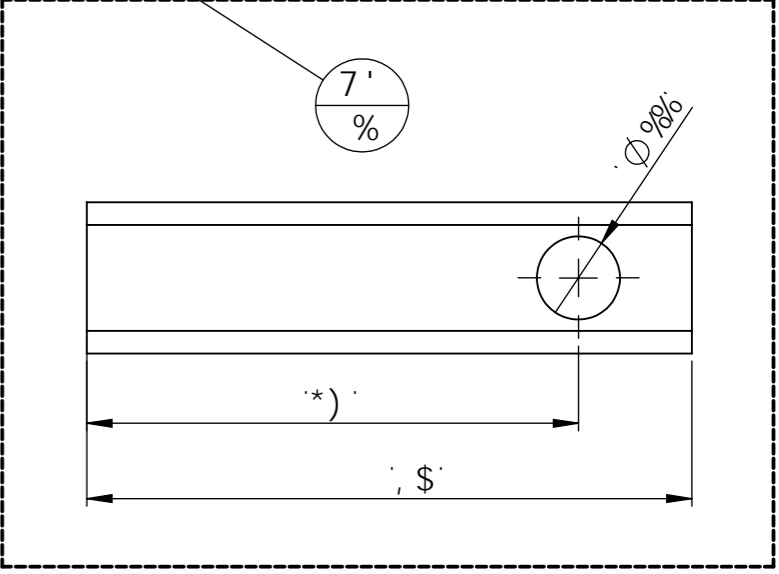
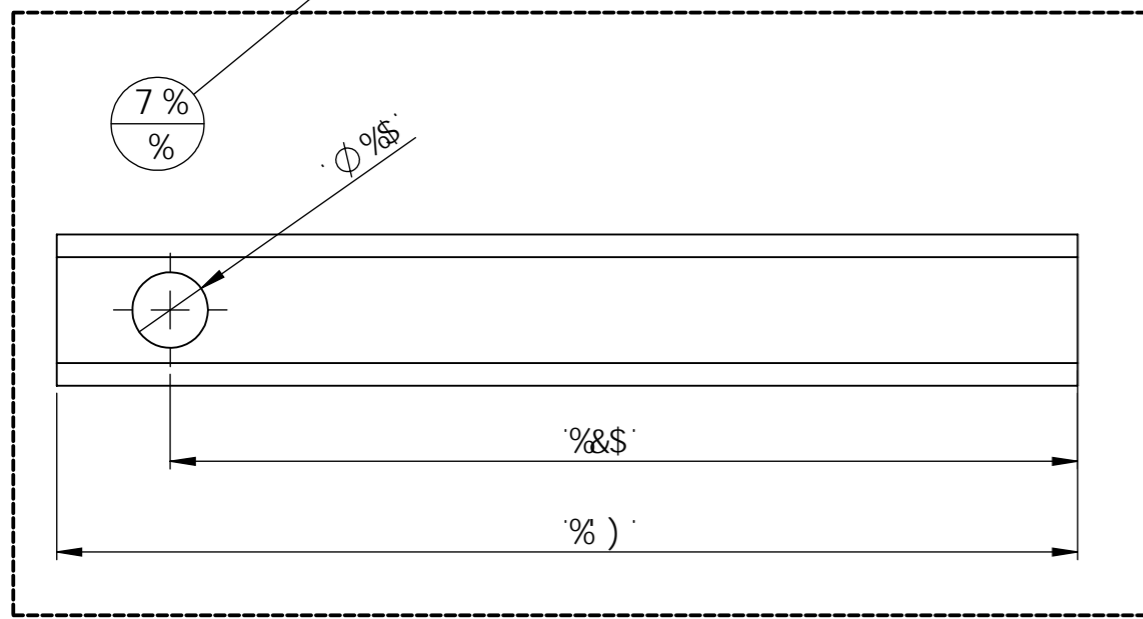
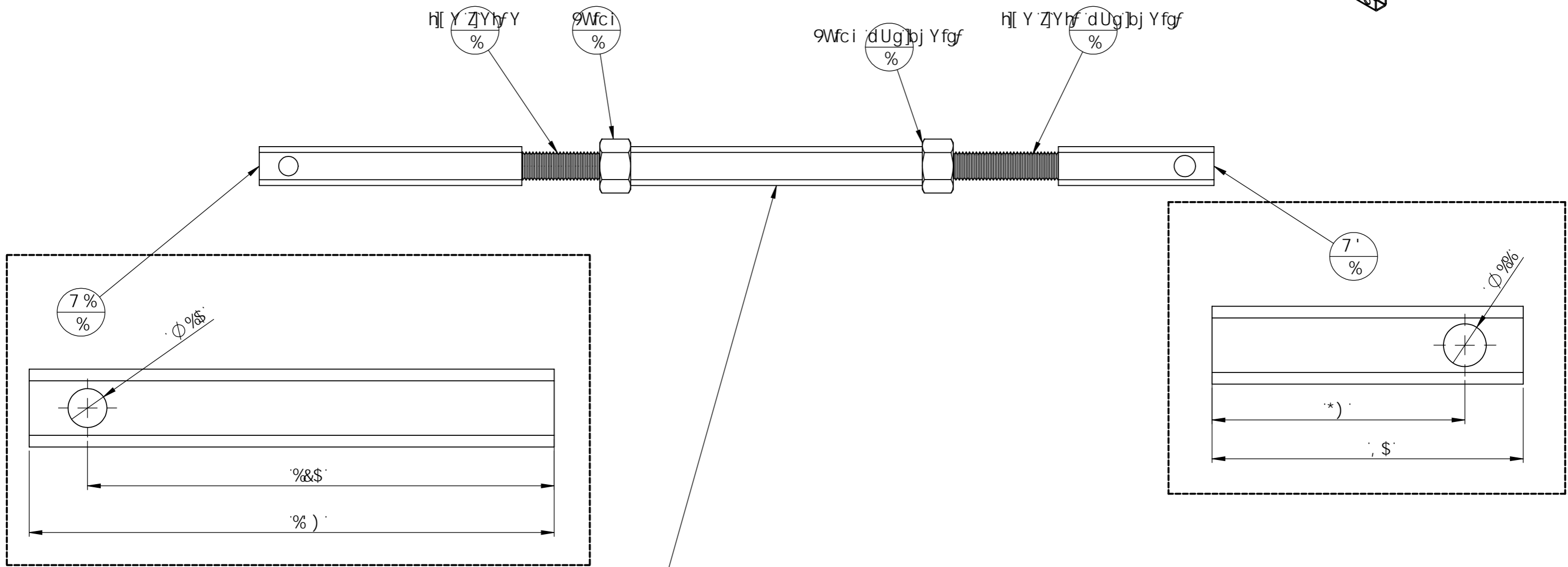
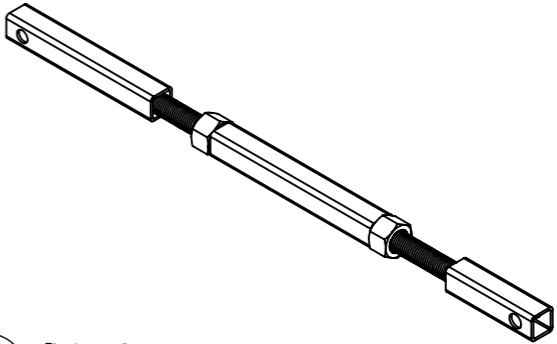

Bš	8fgl[bUhcb	@b[iYi f	E hf
7 %	H VY 'Wuff' &\$'i' &	%)	%
7 &	H VY 'Wuff' &\$'i' &	% \$	%
7'	H VY 'Wuff' &\$'i' &	, \$	%
9Wfci	9Wfci 'A %' 'Vfi h		%
9Wfci	9Wfci 'A %' 'Vfi h]bj Yfgf		%
h[Y ZYhf Y	h[Y ZYhf Y « %*	%+\$	%
h[Y ZYhf Y	h[Y ZYhf Y « %* 'dUg]bj Yfgf	%+\$	%

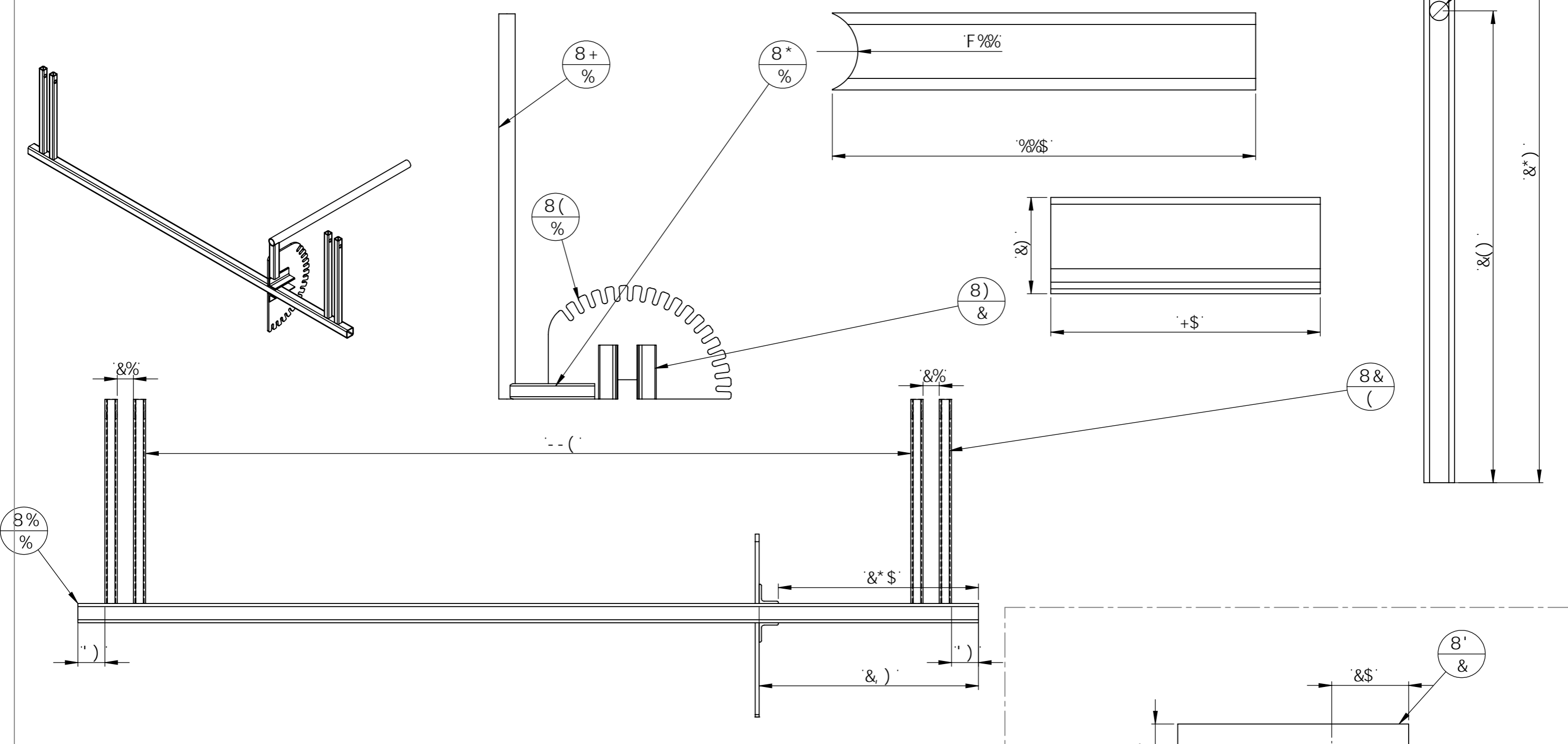

Bš	8fgj[bUh]cb	@b[i Yi f	E hf
8%	h VY 'WUff' &) 'l' &	%%+\$	%
8&	H VY 'WUff' %* 'l' &	&*)	(
8(ƒcei c]g8(%
8)	7 cfb], fY &) 'l' & 'l' "	+\$	&
8*	H VY 'WUff' &\$'l' &	%%%\$	%
8+	h VY 'fcbX' &%" 'l' &) \$\$	%

Bš	8fgj[bUh]cb	@b[i Yi f	E hf
8'	f hff 'fcbX' « &\$	*\$	%

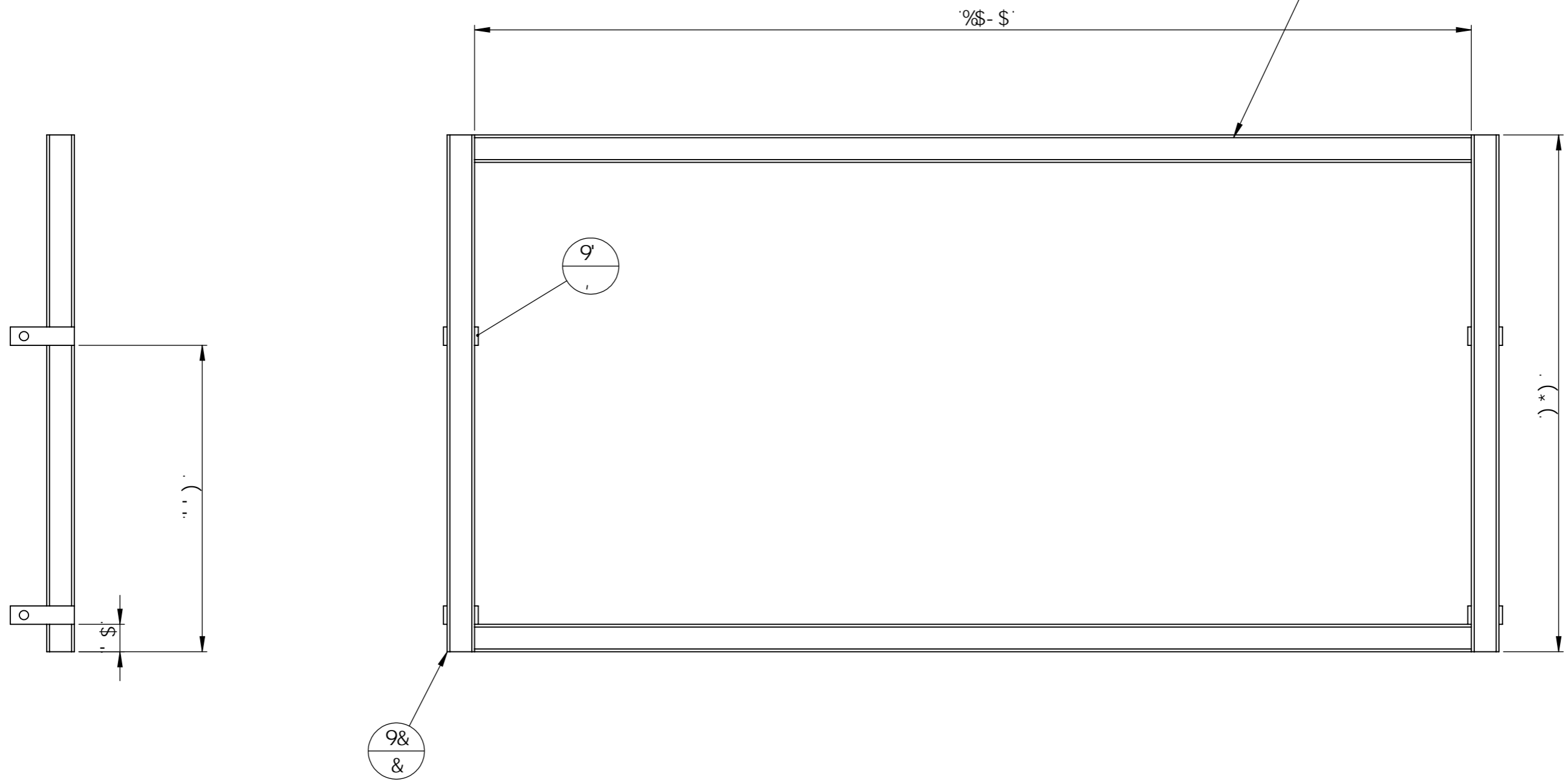

Bš	8fgl[bUh]cb	@b[i Yi f	E hf
9%	H VY 'WUff' '\$' I &	%'-\$	&
9&	H VY 'WUff' '\$' I &)*	&
9'	:Yfd'Uh&\$'I ('	+\$,

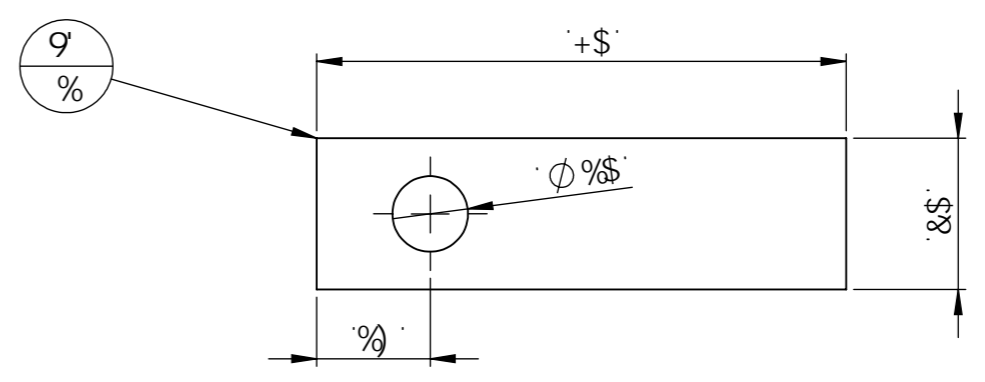

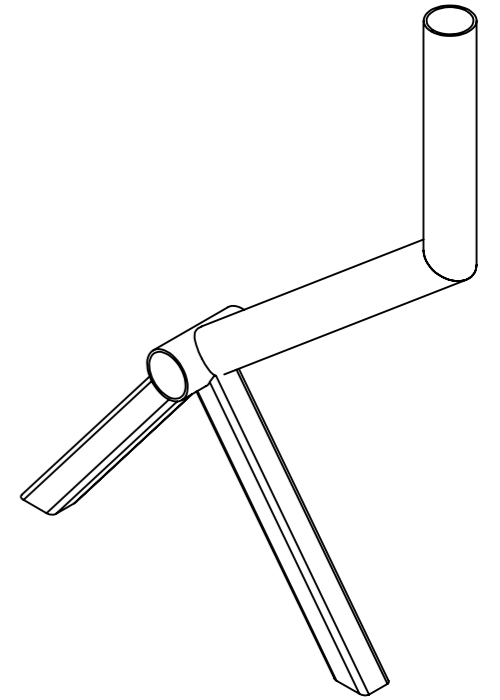
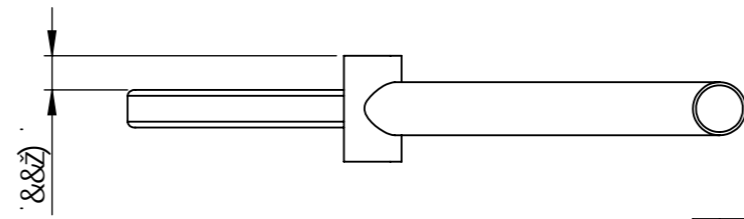
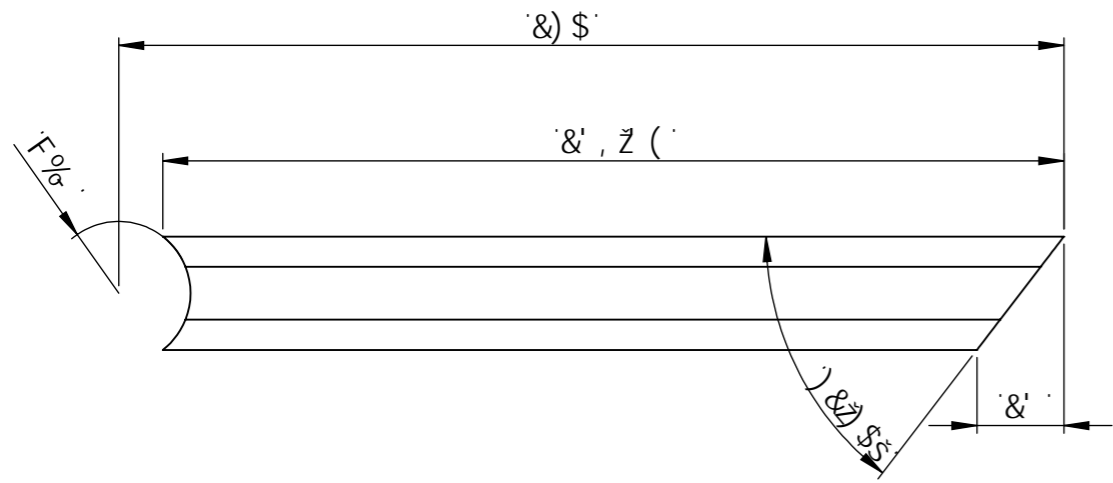

Bš	8fgl[bUh]cb	@b[i Yi f	E hf
; %	h VY WUff &' l' &	&' \$	&
; &	A cmYi 'dfXU]Yf		%
; ' .	h VY 'fcbX') l' &	' \$\$	%
; (h VY 'fcbX') l' &	&' \$\$	%

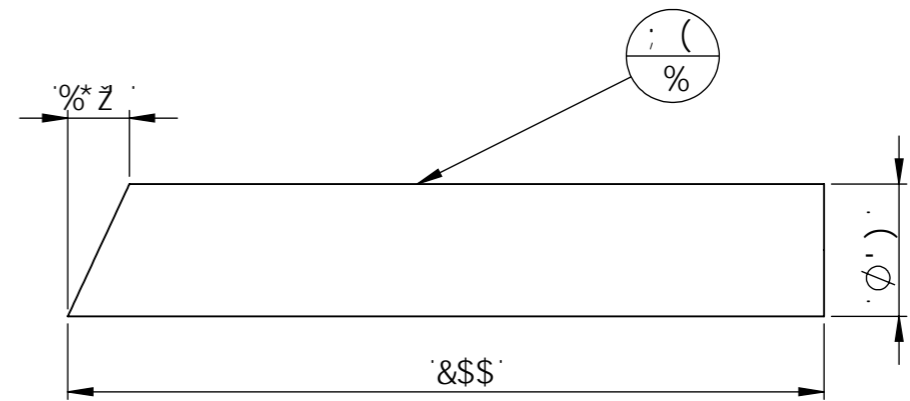
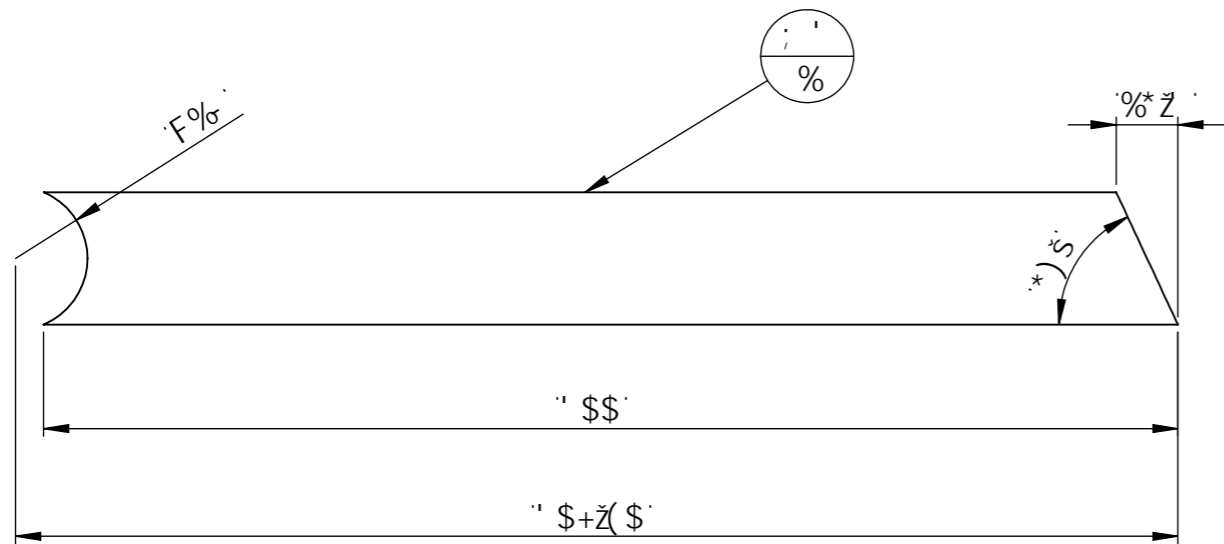
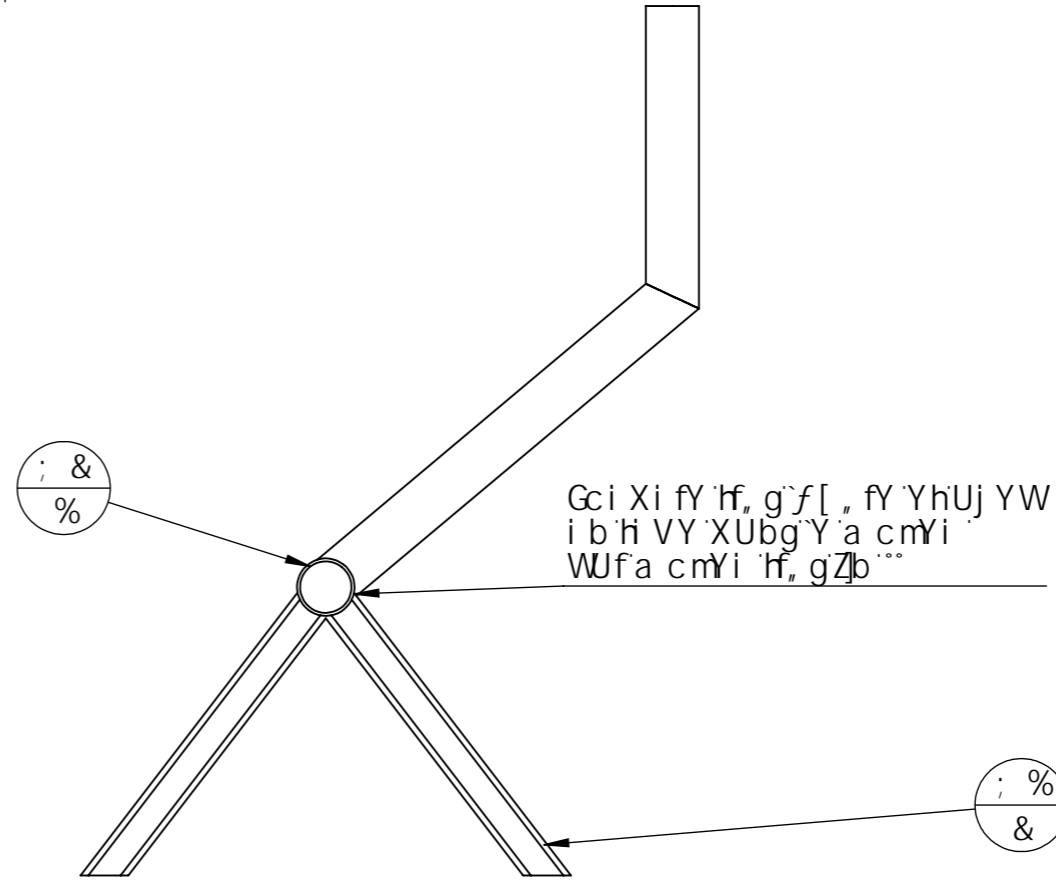

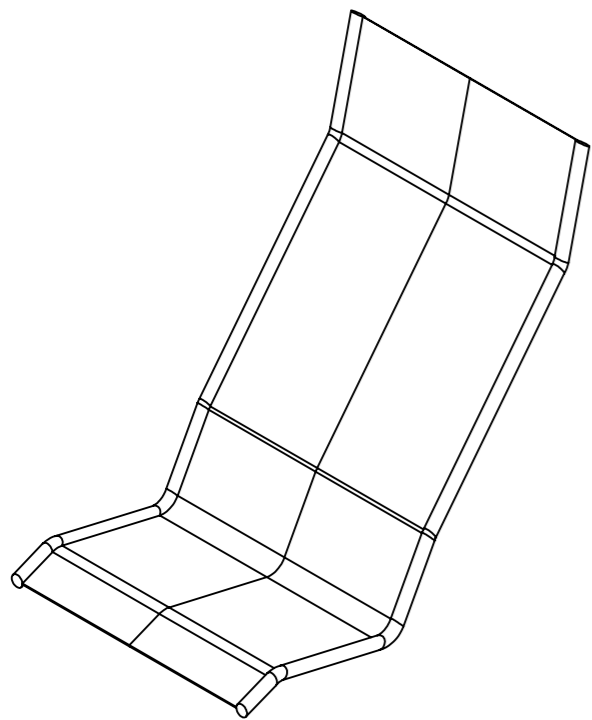
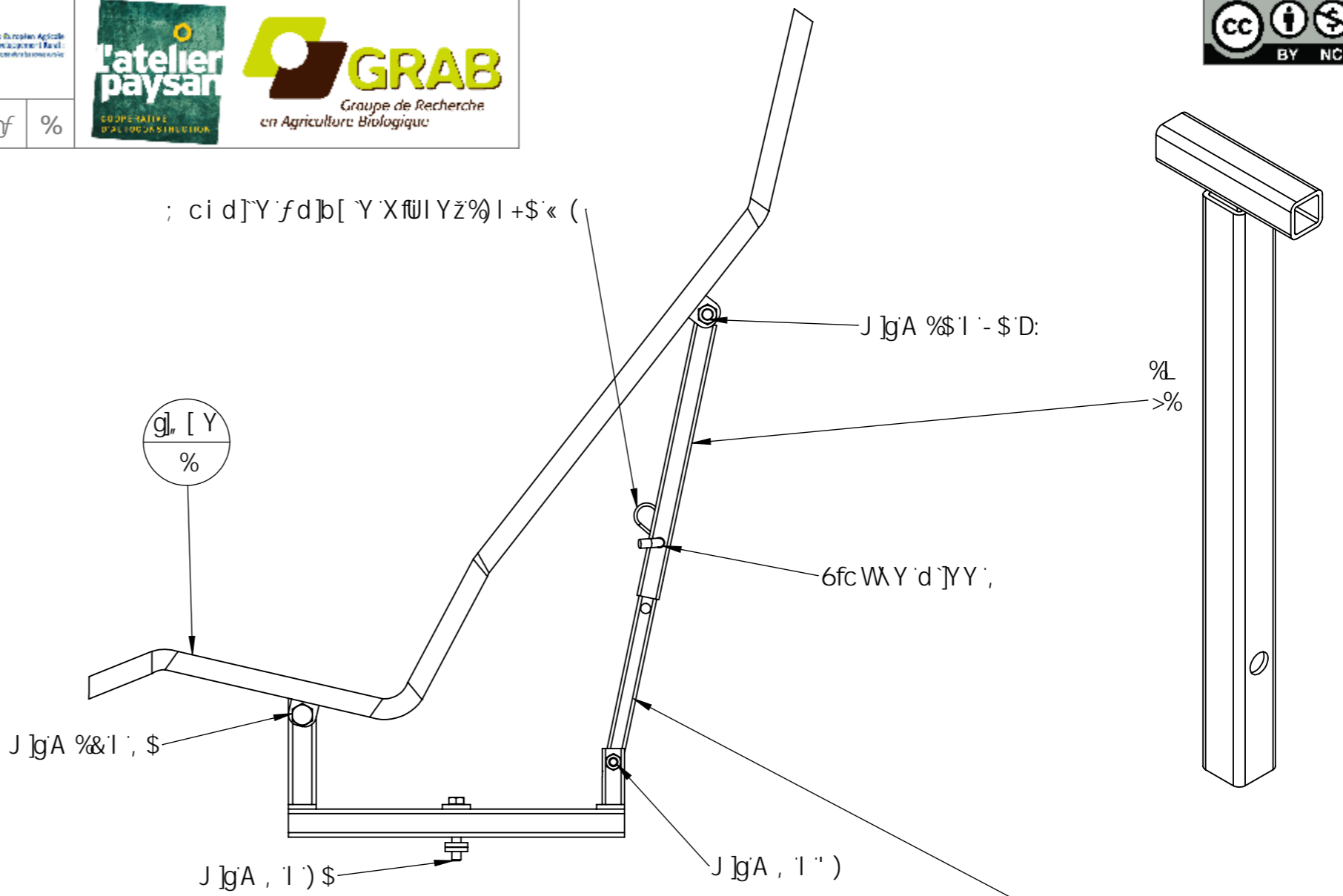
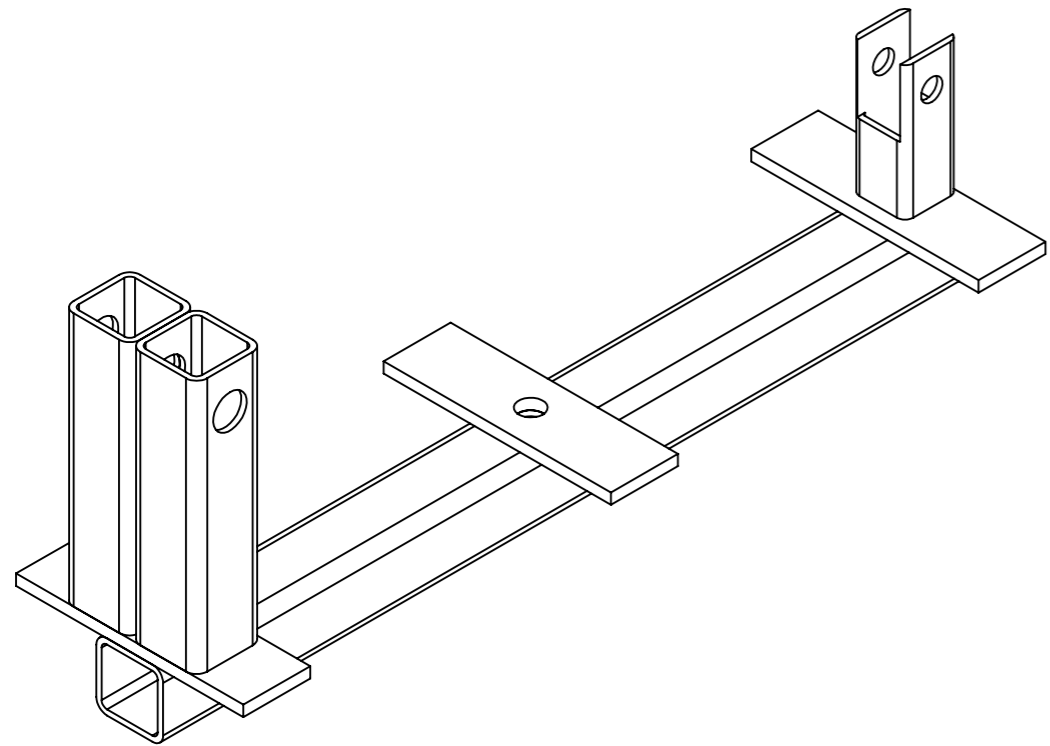

Bš	8fgl[bUh]cb	@b[i Yi f	E hf
g], [Y	G], [Y] f'c' Wci Wf		%
>%&	H VY'WUff' &\$'l' &	&) \$	%
>%"	H VY'WUff' %* 'l' &	&) \$	%
6fc WY'd]YY',	f]hf' fc bX'« ,	%/\$	%
9%&	h VY'WUff' &) 'l' &	' \$\$	%
9%&	h VY'WUff' &) 'l' &	-)	&
9%"	: Yfd'Uh&) 'l' (,)	&
9%(H VY'WUff' &\$'l' &) \$	%
J]g<YIU[cbUY	J]g\YIU[cbUY 'A , l') \$		%
>%&	H VY'WUff' %* 'l' &	*	%
9Wfci	9Wfci 'A , 'Ui hc ZY]bf		%
9Wfci	9Wfci 'A %\$'Ui hc ZY]bf		%
J]g<YIU[cbUY	J]g\YIU[cbUY 'A %\$'l' - \$'D:		%
J]g<YIU[cbUY	j]g\YIU[cbUY 'A , l')		%
9Wfci	9Wfci 'A %&'Ui hc ZY]bf		%
9%)	: Yfd'Uh&) 'l' (,)	%
J]g<YIU[cbUY	J]g\YIU[cbUY 'A %&'l' , \$		%
9%&	: Yfd'Uh&\$'l' (, \$	&
; ci d]Y'fd]b[Y'XfWlYž%l +\$'« (; ci d]Y'fd]b[Y'XfWlYž%l +\$'« (%

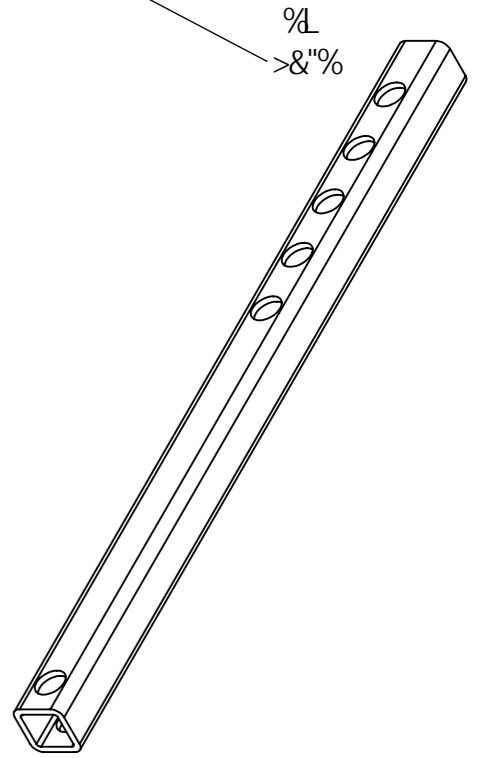

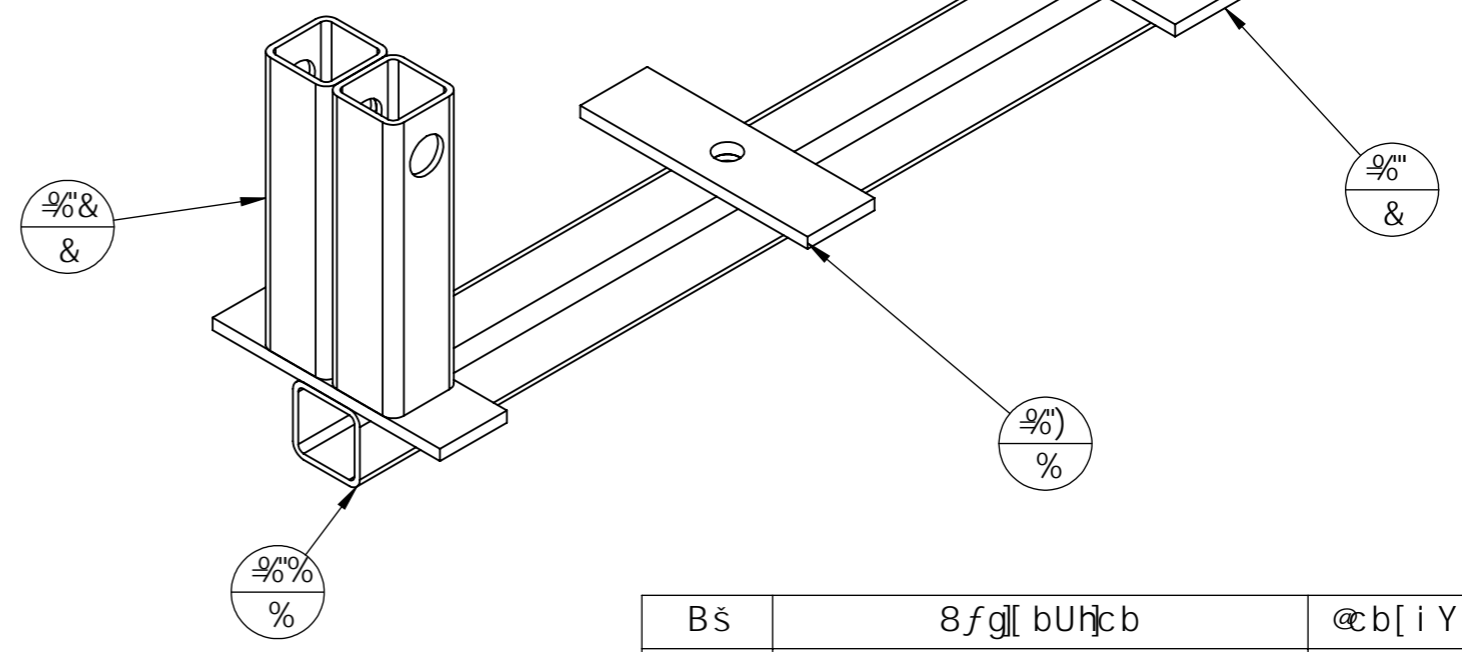
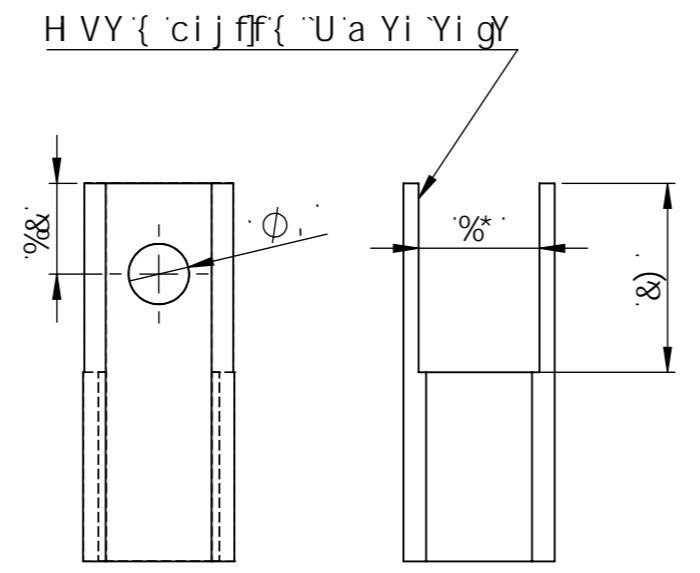
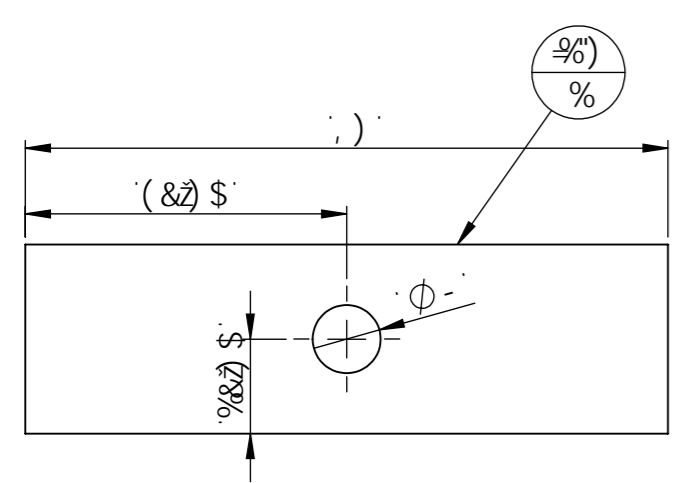
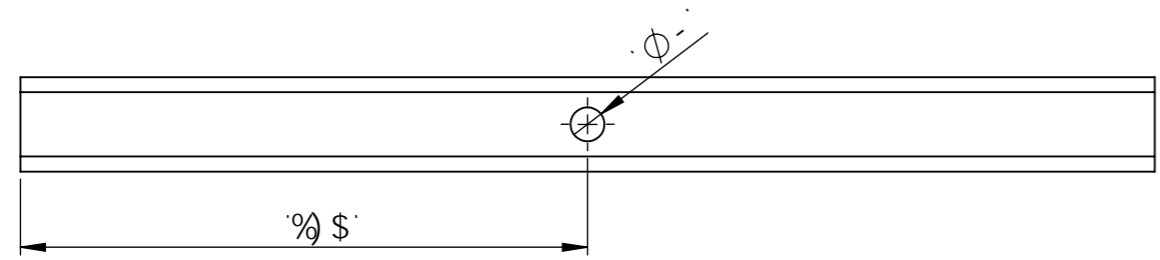
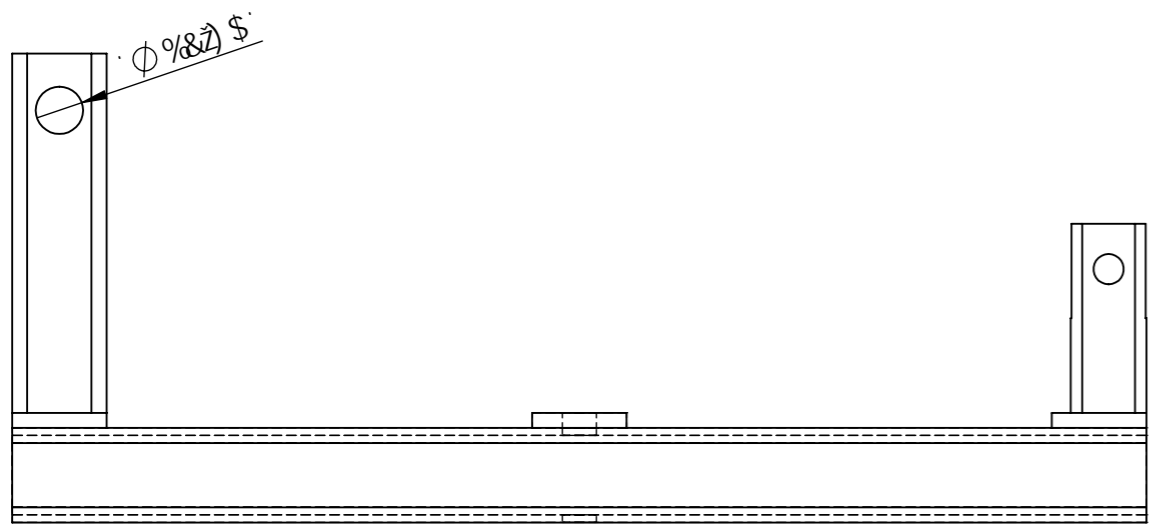
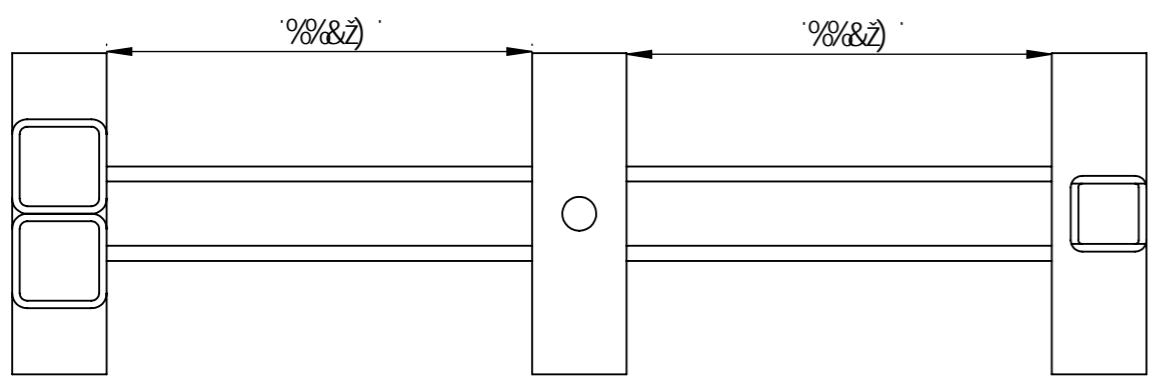

Bš	8fgl[bUhc b	@b[i Yi f	E hf
%\"/>			

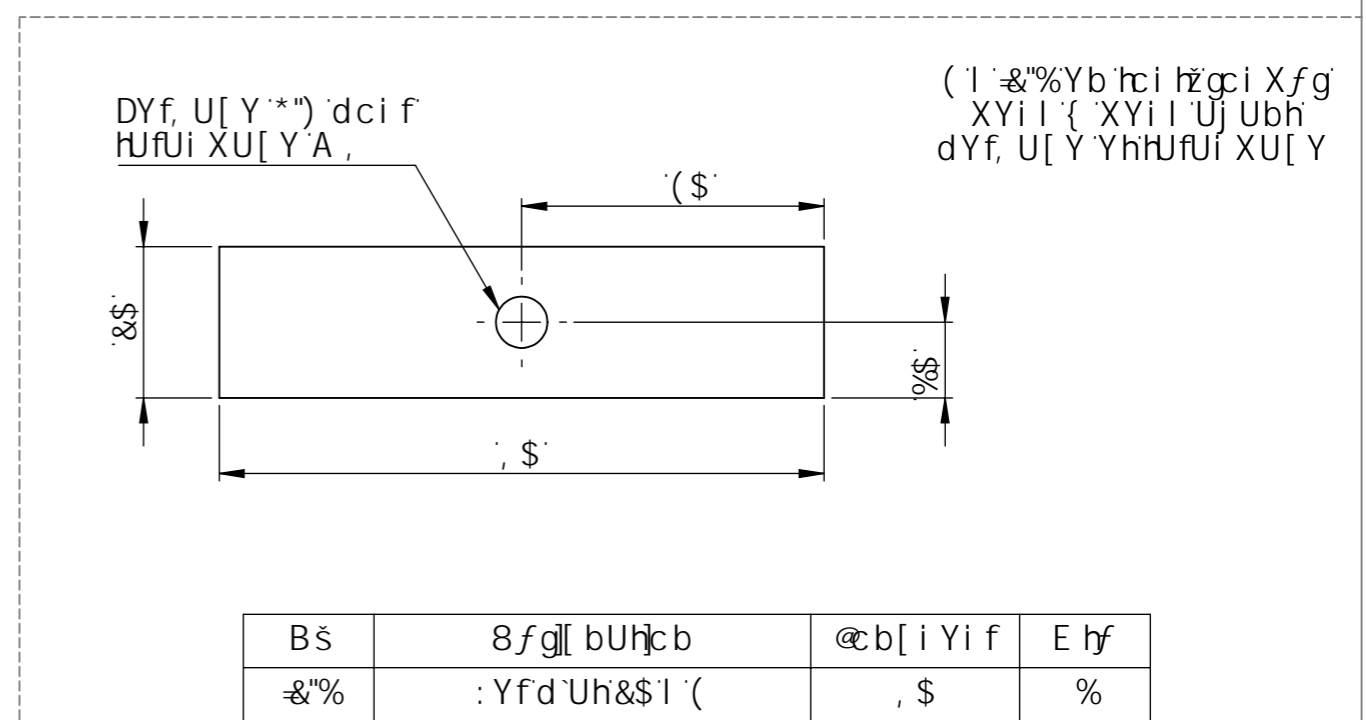

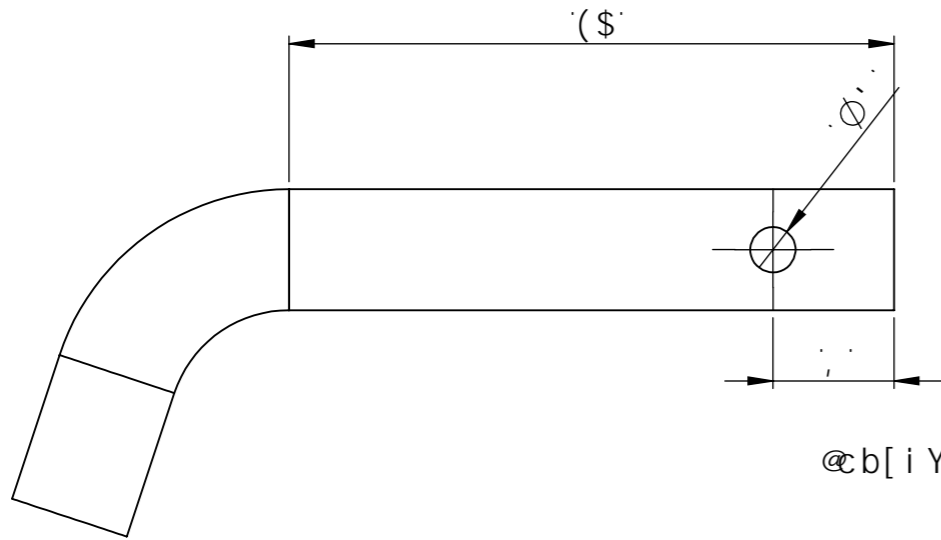

@b[i Yi fUj Ubhd]U[Y : '%\$' a a

Bš	8fgj[bUhc b	@b[i Yi f	E hf
6fc W Y d]Y Y ,	f h f f ' f c b X « ,	%&\$	%

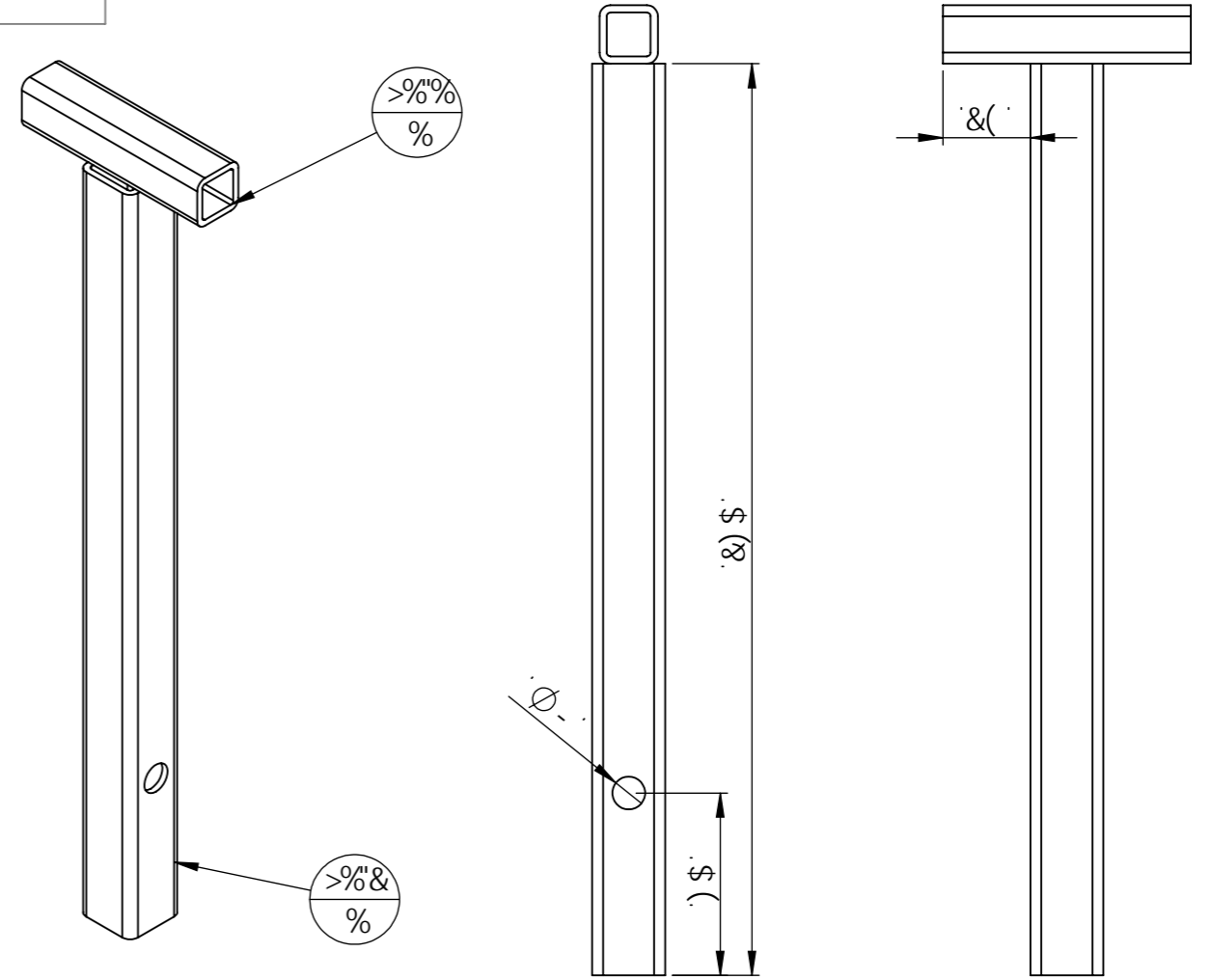

Bš	8fgj[bUhc b	@b[i Yi f	E hf
>%''%	H VY 'Wufff '%* 'l' &	*	%
>%''&	H VY 'Wufff '&\$'l' &	&) \$	%

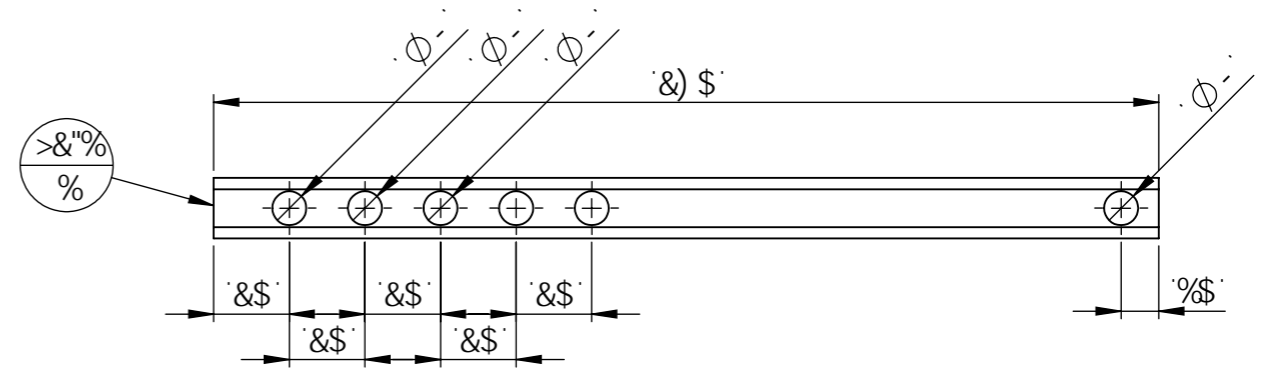

Bš	8fgj[bUhc b	@b[i Yi f	E hf
>%''%	H VY 'Wufff '%* 'l' &	&) \$	%

@`Zci fVXY`Xfc]Y`Ygh`U`
 gna fh]ei Y`XY`U`Zci fVXY`
 [Ui VXY`gUbg`Ygd], Wg@%*`
 Yh@%+`

5HYbh]cb`Ui`gYbg`°

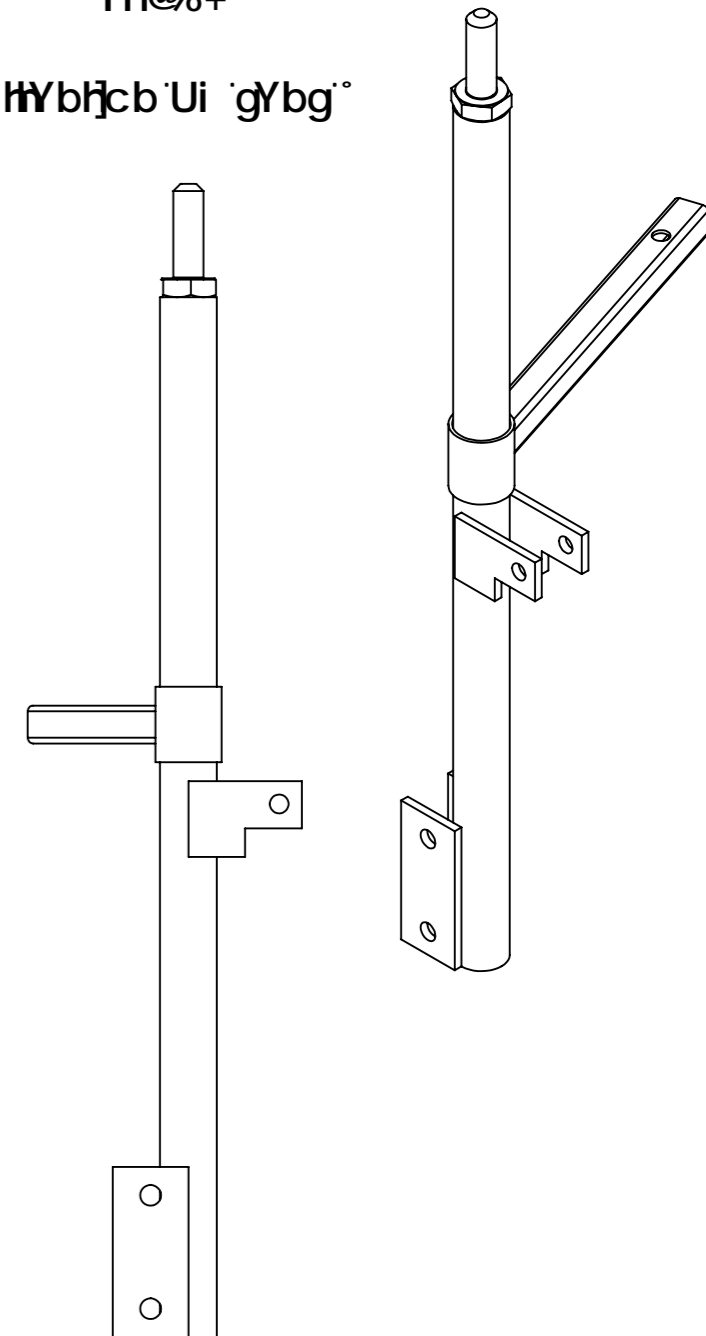
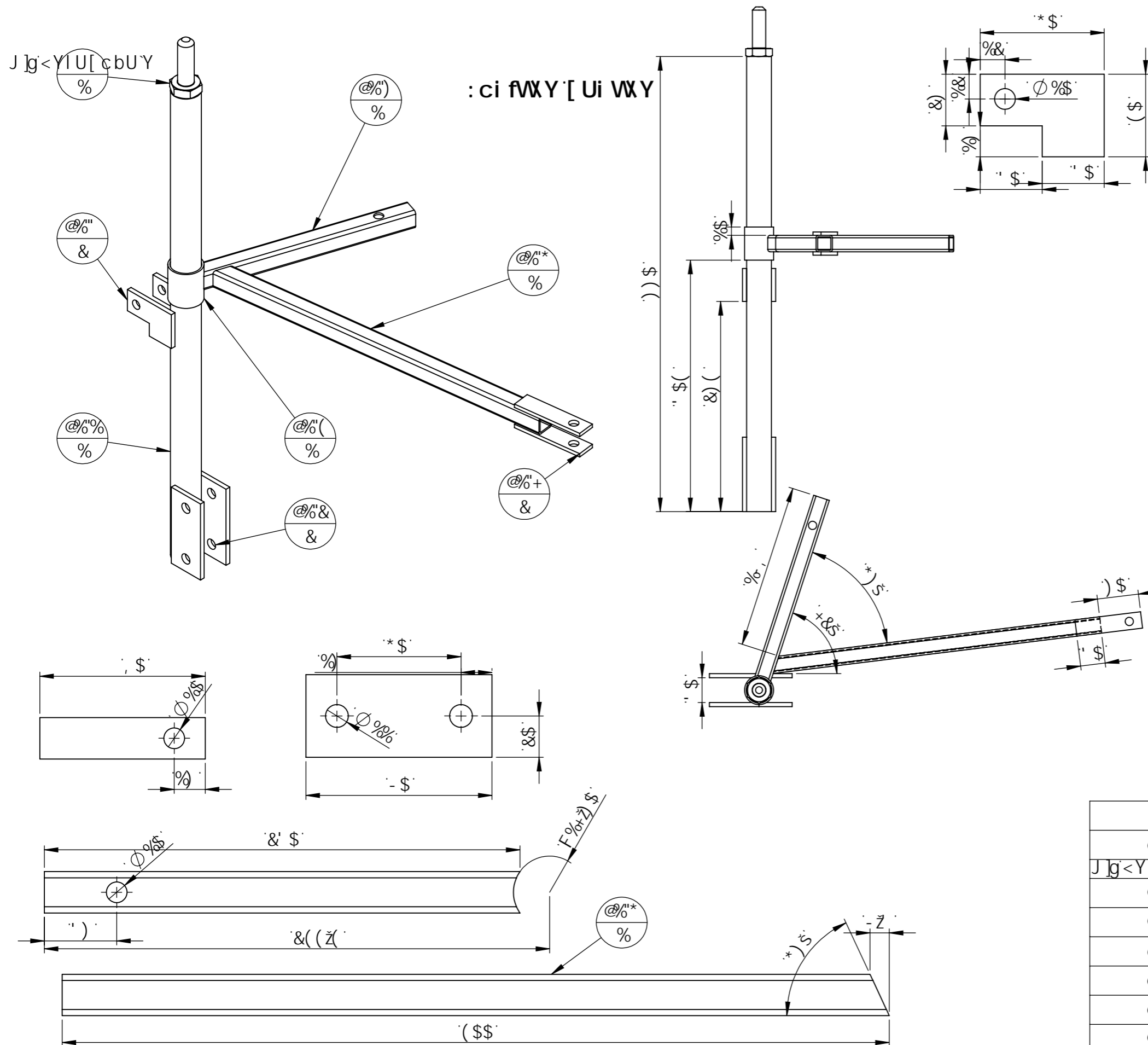

Bš	8fgj[bU]cb	@b[i Yi f	E hf
@%%	h VY`fh]f`fcbX`" \$i`")) \$	%
J]g<YIU[cbUY	J]g\YIU[cbUY`A`%`I`)" \$		%
@%"	: Yfd`Uh(\$i`)	* \$	&
@%&	: Yfd`Uh(\$i`)	- \$	&
@%(h VY`fcbX`") i`"&	(\$	%
@%)	H VY`WUff`&\$i`&	& \$	%
@%*	H VY`WUff`&\$i`&	(\$\$	%
@%+	: Yfd`Uh&\$i`(`	, \$	&

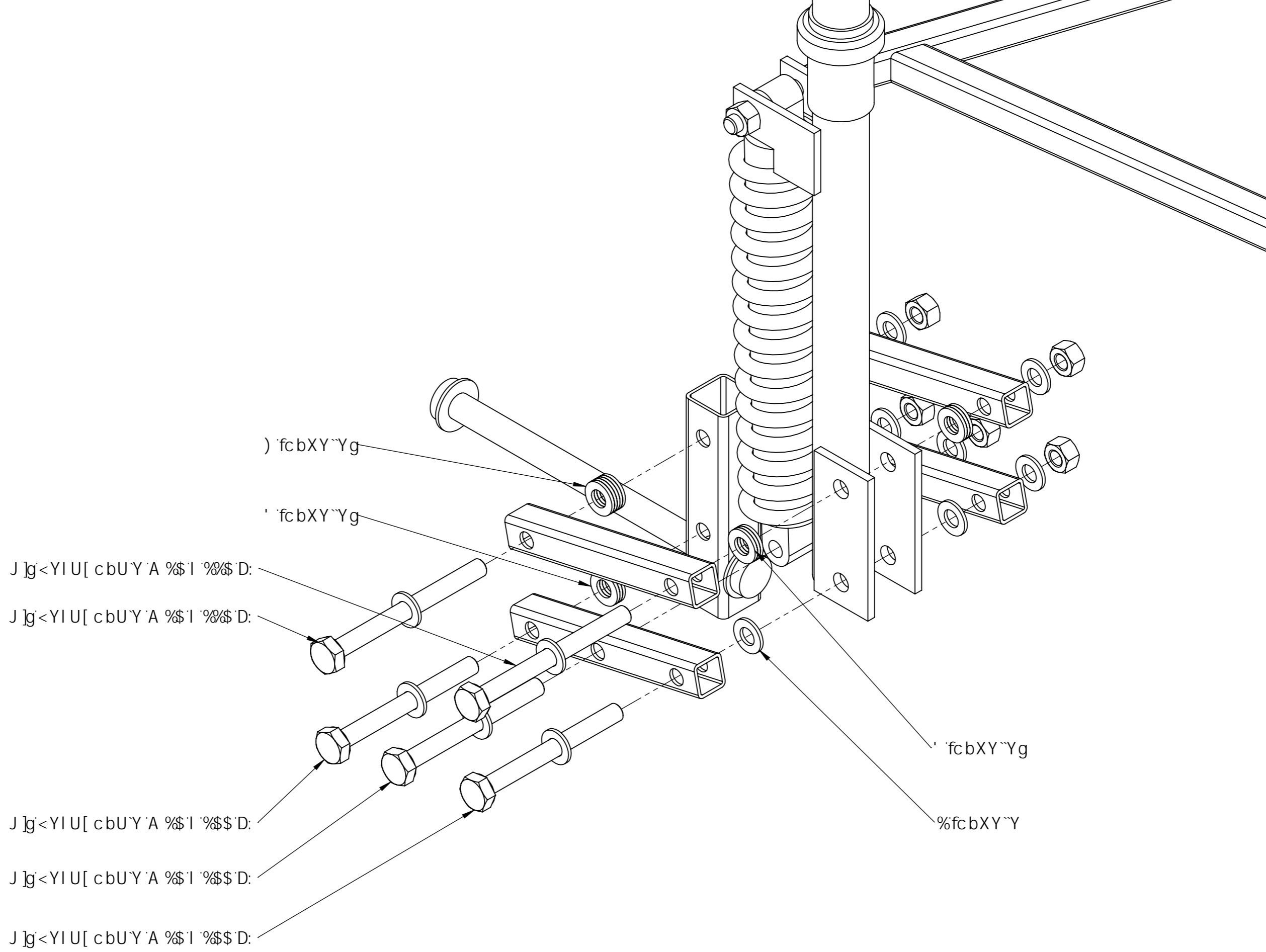

“; i Xcb” XY Wca a UbXY

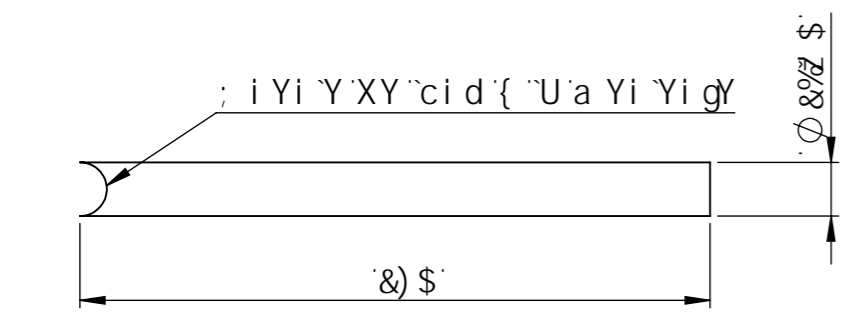
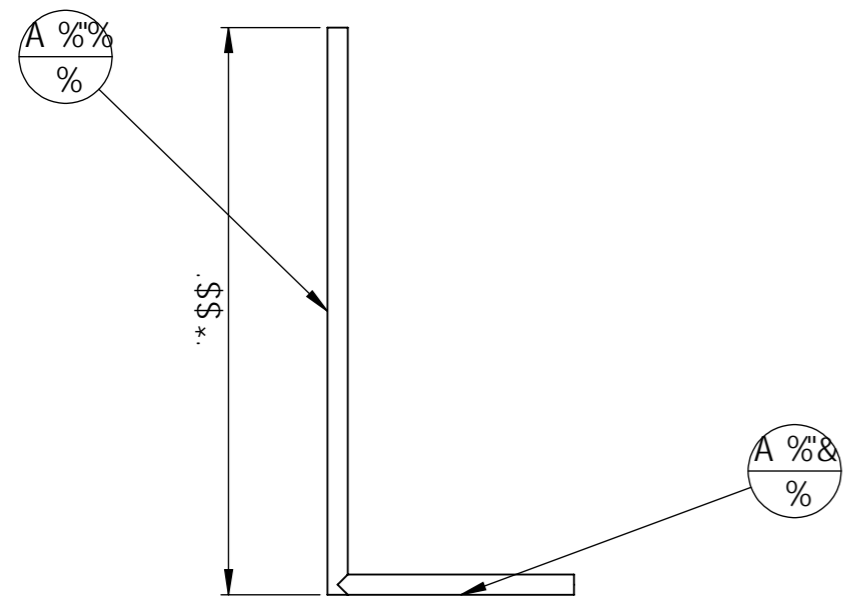

Bš	8fgl[bUh]cb	@b[i Yi f	E hf
A %%	hi VY' fcbX '&%" i' &	*\$ \$	%
A %&	hi VY' fcbX '&%" i' &	&) \$	%

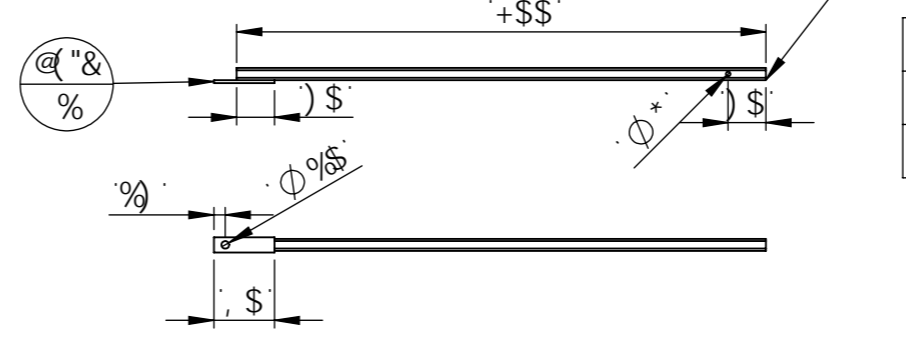

Bš	8fgl[bUh]cb	@b[i Yi f	E hf
@ "%	H VY' Wufff '%* i' &	^{+} \\$ \$	%
@ "%	: Yfd' Uh&\$' i' (, \$	%

Bš	8fgl[bUh]cb	@b[i Yi f	E hf
B %%	hi VY' Wufff '&) i' &	^{+} \\$ \$	%
B %&	hi VY' Wufff '&) i' &	, \$	%
9Wfci	9Wfci 'A %\$' Vfi h		%
J jg< YIU[cbUY	j jg\YIU[cbUY 'A %\$' i' " \$		%
B %"	: Yfd' Uh(\$' i')	% \$	%

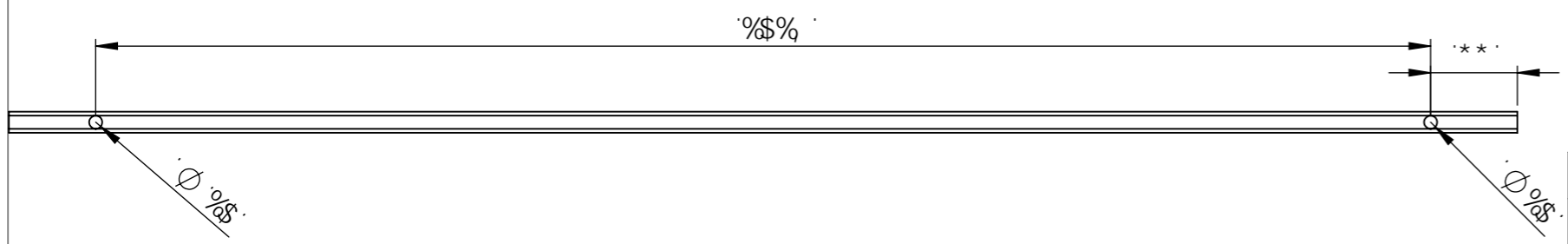
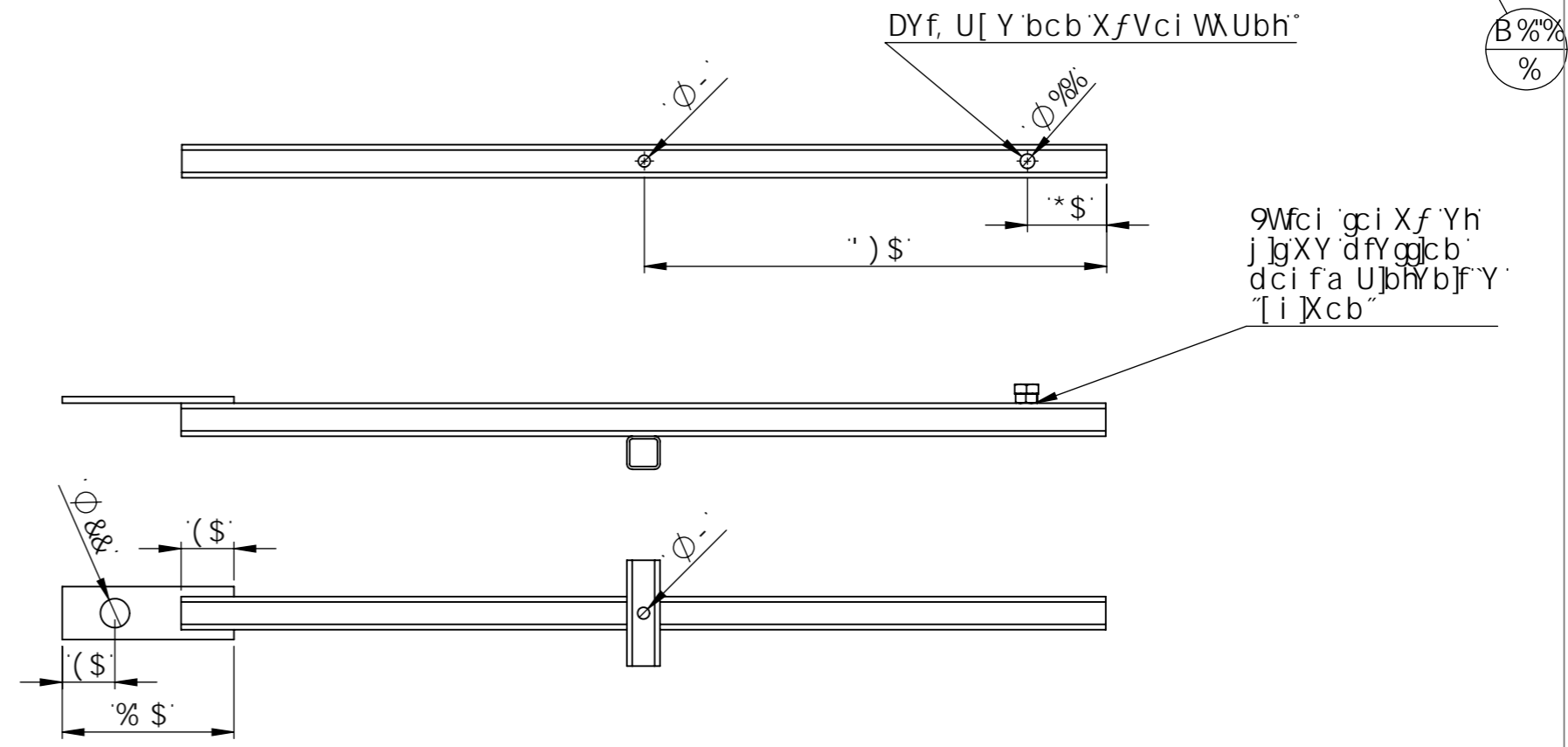
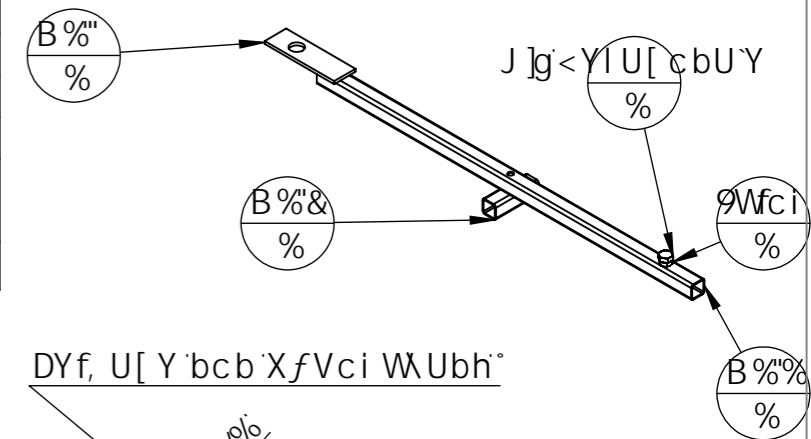

Bš	8fgl[bUh]cb	@b[i Yi f	E hf
@	H VY' Wufff '%* i' &	^{*} \\$ \$	%

D], W' ei j]fY]Y' XYgXYi i' Zi fWYg

Bš	8fg] bU]cb	@b[i Yi fE hf
J]g7 <7	J]g7 <7 ; ' l' &	(
J]g<YI U[cbUY	j]g\YI U[cbUY 'A , ' l')	(
9Wfci	9Wfci 'A , 'Ui hcZY]bf	(
9Wfci	9Wfci 'A %&'Ui hcZY]bf	,
FcbXY`Y	FcbXY`Y « %&'gf f]Y`N	%*
J]g<YI U[cbUY	J]g\YI U[cbUY 'A %&'l')	,
dU]YfWUdYUi	DU]YfWUdYUi «]bh&\$	(
H%	f h]f f'cbX` « &\$	' ' \$ &
H&	h VY`fcbX`&*" - ' l' &")	(, \$ %
8]Zf fYbh]Y`	8]Zf fYbh]Y`	%
d]] bcb	D]] bcb`hci fbf	&
7 ci fcbbY`a cX`%7 ci fcbbY`a ch` (&\$` + XYbhg		%
H	h VY`fcbX`&*" - ' l' &")	(\$\$ %

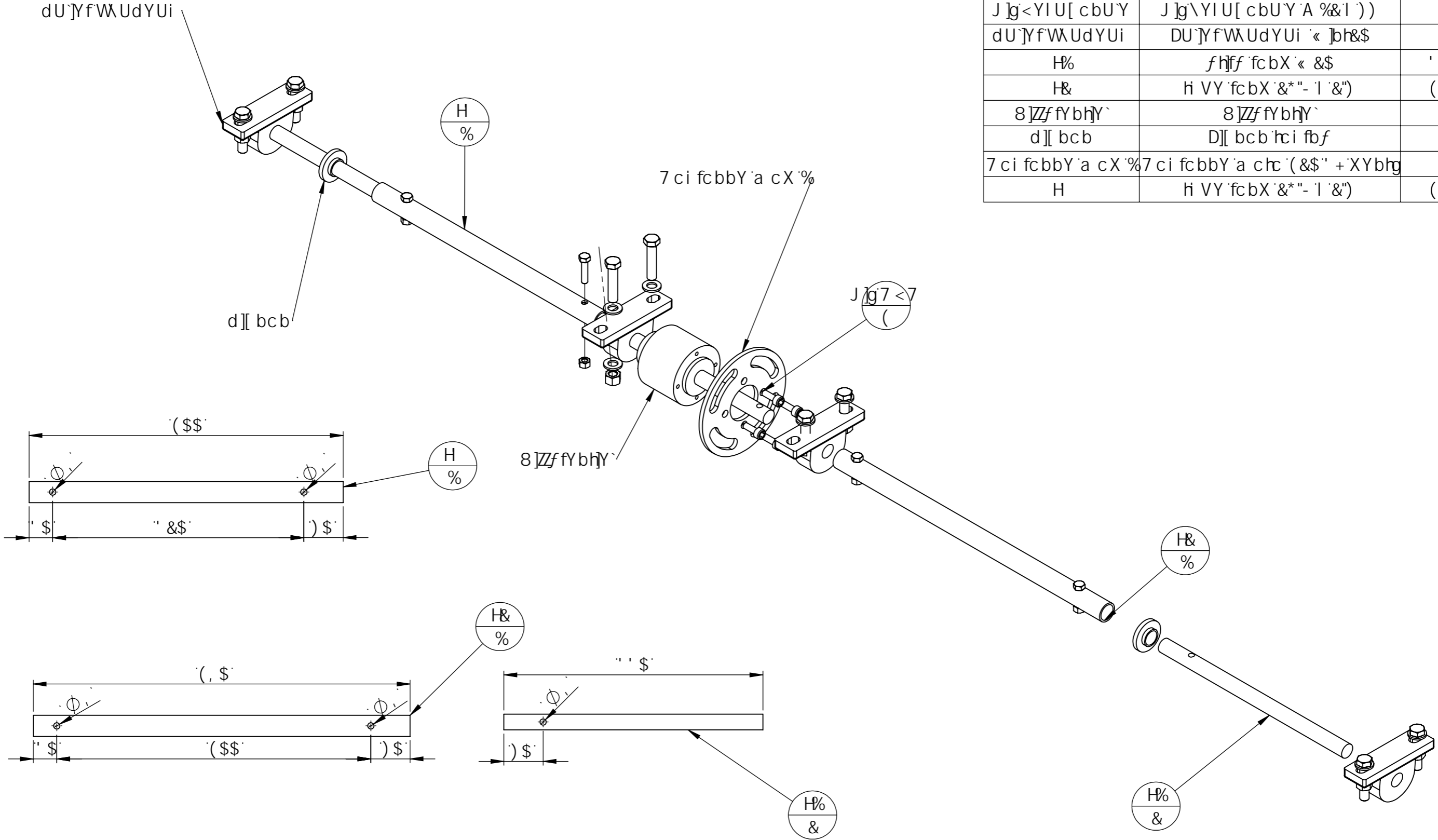

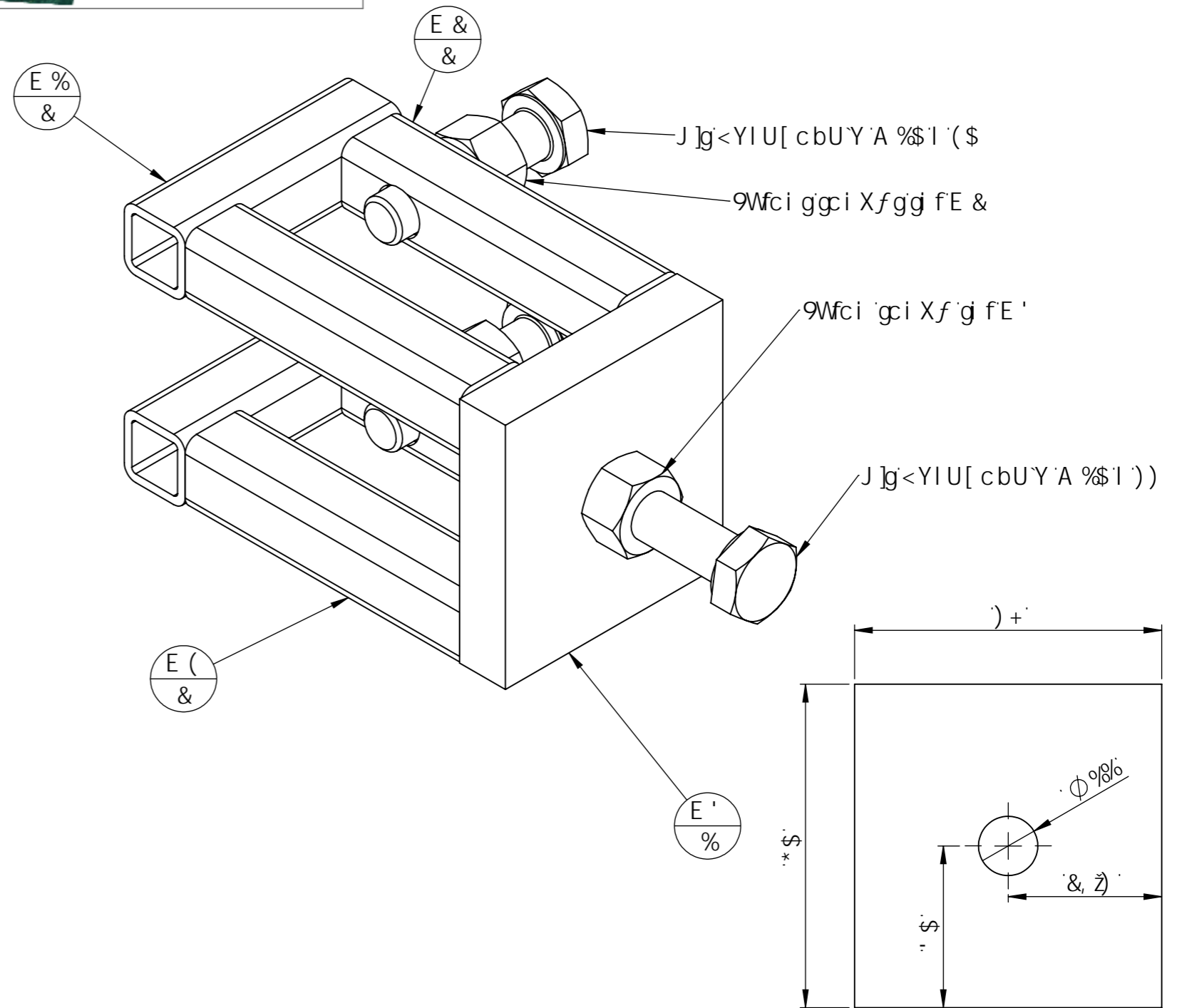
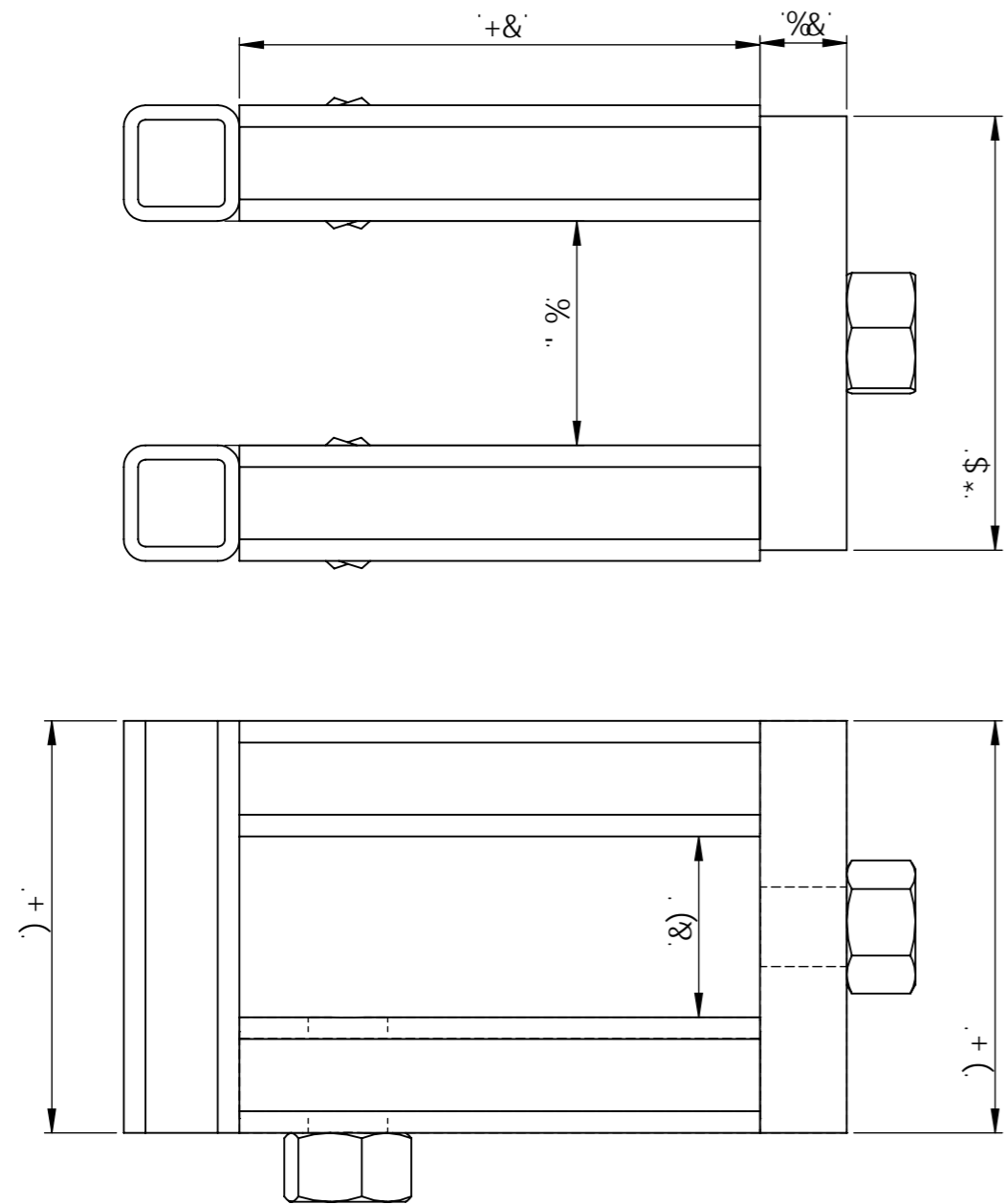

Bš	8fg] bUhc b	@b[i Yi f	E hf
E %	H VY 'WUff' %* 'I ' &) +	&
E &	H VY 'WUff' %* 'I ' &	+&	&
E ')	: Yf'd 'Uh* \$' I ' %&) +	%
J]g<YIU[cbUY	j]g\YIU[cbUY 'A %\$' I '))		%
9Wfci	9Wfci 'A %\$' Vfi h		'
E (H VY 'WUff' %* 'I ' &	+&	&
J]g<YIU[cbUY	J]g\YIU[cbUY 'A %\$' I ' (\$		&

DYf, U[Y' bcb' XfVci WUbh

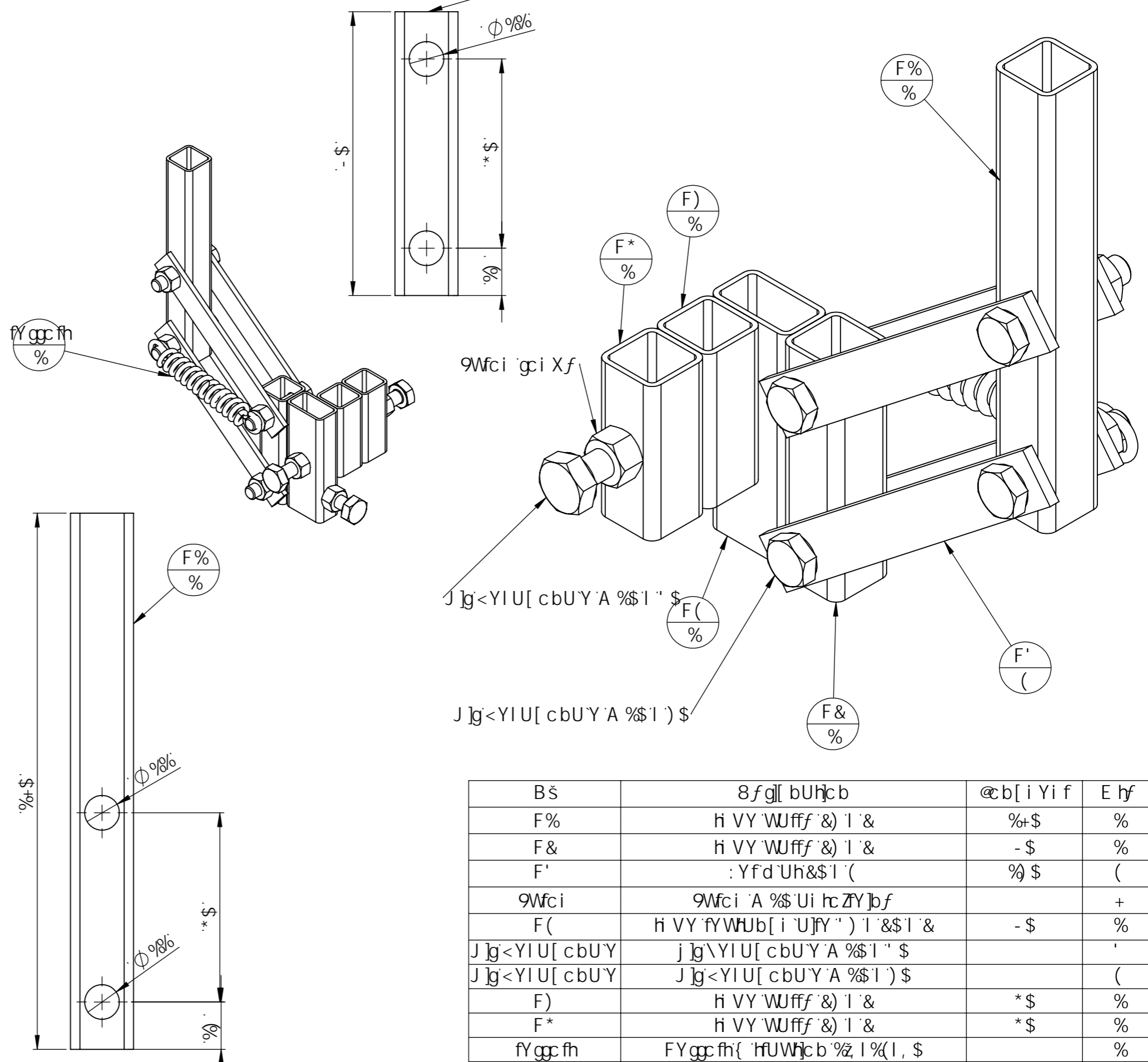
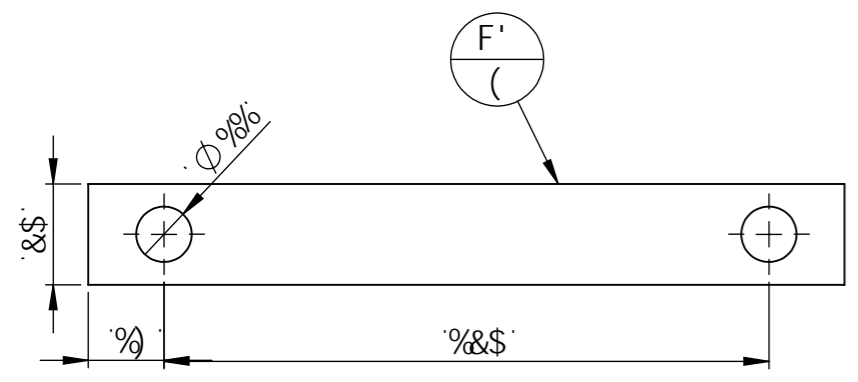
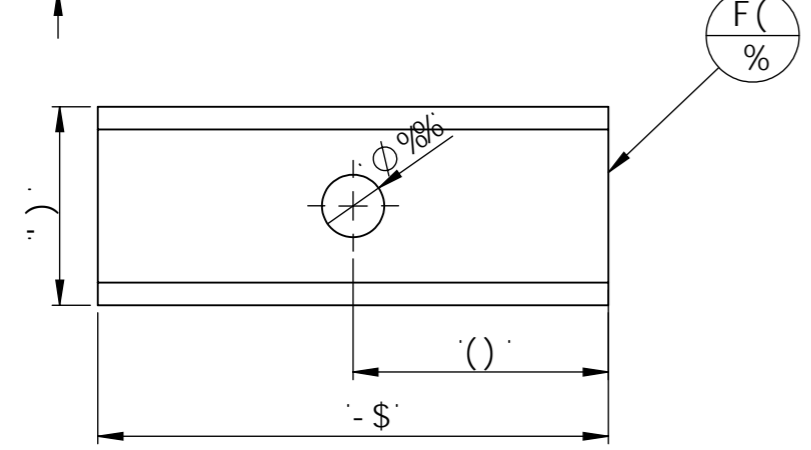
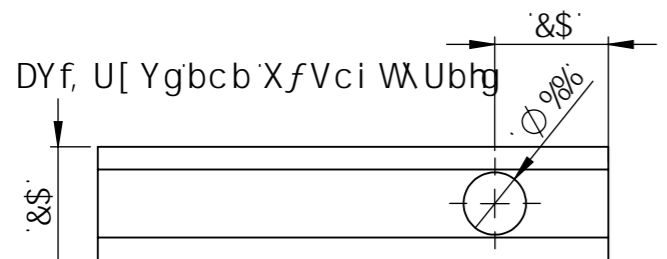
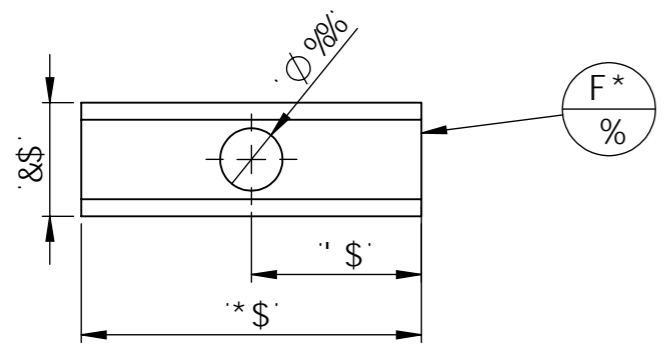

BŠ	8fgl[bUh]cb	@b[i Yif	E hf
F%	hi VY' WUff' &) i' &	%+\$	%
F&	hi VY' WUff' &) i' &	-\$	%
F'	: Yfd'Uh&\$'I' (%\$	(
9Wfci	9Wfci 'A %\$'Ui hcZY]bf		+
F(hi VY' fYWU]b[i' U]fY') i' &\$'I' &	-\$	%
J]g<YIU[cbUY	j]g\YIU[cbUY'A %\$'I' '\$		'
J]g<YIU[cbUY	J]g<YIU[cbUY'A %\$'I') \$		(
F)	hi VY' WUff' &) i' &	*\$	%
F*	hi VY' WUff' &) i' &	*\$	%
fYggc fh	FYggc fh{ hfUWh]cb %Z, l%I, \$		%

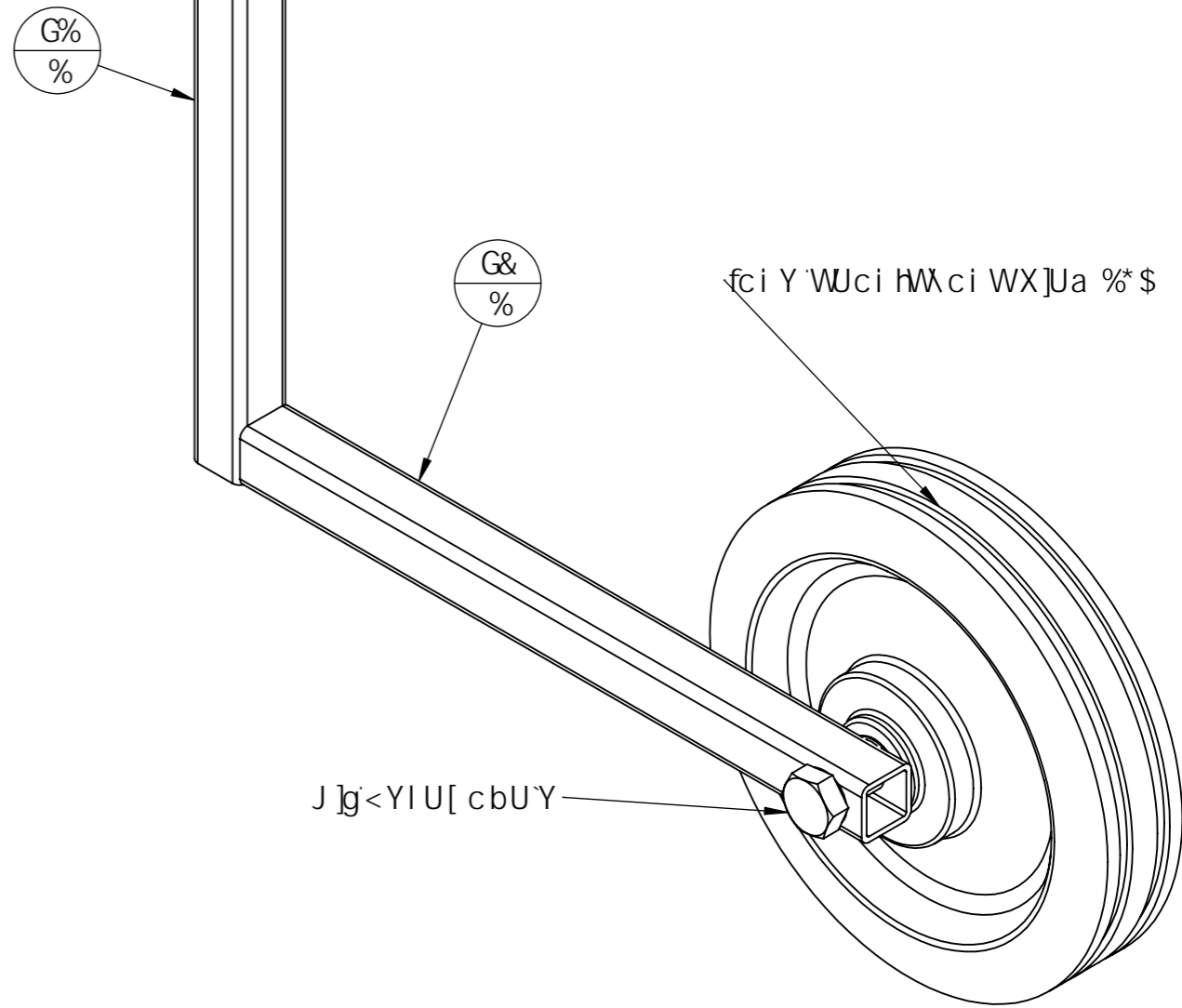
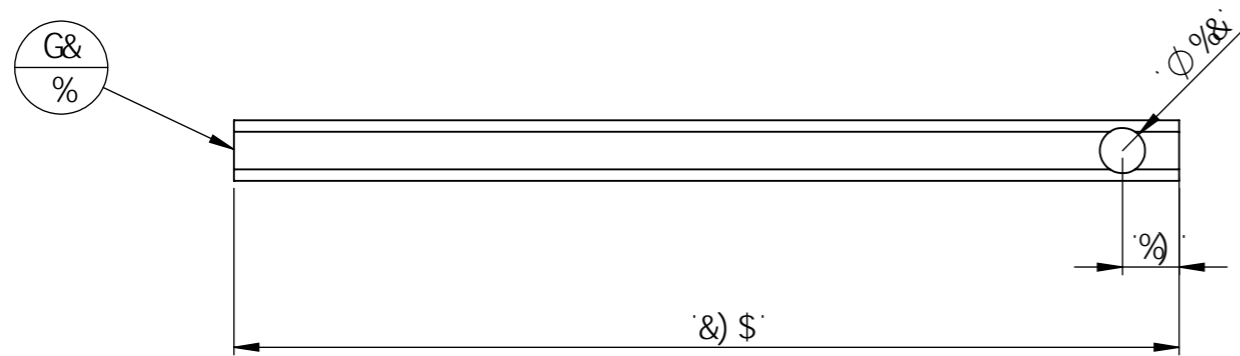
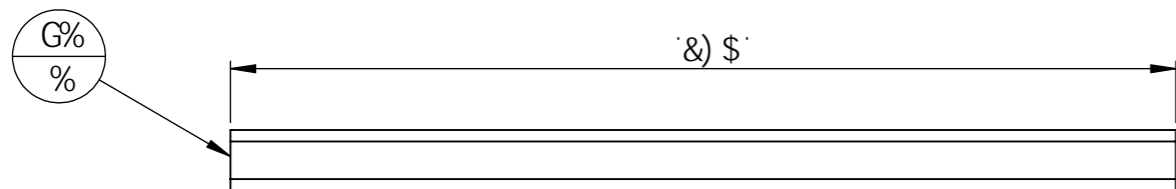

Bš	8fg[bUhc b	@b[i Yi f	E hf
G%	H VY 'Wff' &\$'i `&	%\$- \$	%
G&	H VY 'Wff' &\$'i `&	&) \$	%
9Wfci	9Wfci 'A %&'Ui hc ZY]bf		%
fci Y 'Wfci hWci WXJUa %* \$	Fci Y 'Wfci hWci W« %* \$		%
J]g<YI U[cbUY	J]g\YI U[cbUY 'A %&'i '%\$\$		%
Xci]Y 'XfU'Y]bP&'YI h&\$	8ci]Y 'XfU'Y «]bP&'# « YI h&\$ '#@ -		%



Fonds Européen Agricole pour le Développement Rural



Bš	8fgl[bUhc b	@b[i Yi f	E hf
5%	H VY WUff %' I &	%&(&	&
5&	H VY WUff %' I &	%&\$	&
5'	H VY WUff %' I &	- ,	(
5(H VY WUff %' I &) ,	&
5)	H VY WUff %' I &	(&\$	(
5*	H VY WUff %' I &	%&\$	(
5+	H VY WUff %' I &	%(&	%
5,	H VY WUff %' I &	%&&	%
5-	H VY WUff %' I &	%)	&
5%	H VY WUff %' I &	(((\$	&
5%	H VY WUff %' I &	&\$)	&
5%&	H VY WUff %' I &) - ,	&
5%	H VY WUff %' I &	*%)	&
5%	H VY WUff %' I &	*&+	&
5%	H VY WUff %' I &	%\$	&
5%	H VY WUff %' I &	(' \$	&
5&	DUhby Zci fMY		(
5&)	H VY WUff %' I &	' \$	&
5&+	H VY WUff %' I &	%&\$	%
5&	7c fb], fY &' I &' I "	%\$	%
5&-	H VY WUff %' I &	, \$	%
5' \$	H VY WUff %' I &	&\$	%
h[Y ZYhfY	h[Y ZYhfY A %&	')	%
5%*	H VY WUff %' I &	' *)	&
5&&	DUhby a chYi f		&
5&\$	H VY WUff %' I &	*) \$	&
5&%	H VY WUff %' I &) ,	&
5&*	:Yfd'Uh' \$I)	*\$	(
5&(&	H VY WUff %' I &	%\$	&
5' %	H VY WUff %' I &	' \$\$	(
5' &	H VY WUff %' I &	(* \$	&
5' "	DUhby XjYWhcb \Ui hY		&
5' (DUhby XjYWhcb VUgY		&
5')	H VY WUff %' I &	%\$	&
5' *	H VY WUff %' I &	%&\$	%
5' +	H VY WUff %' I &	-)	%
5' ,	:Yfd'Uh&\$I (+	(
Jlg<YIU[cbUY	Jlg\YIU[cbUY A , I) \$	%\$	&
5(\$:Yfd'Uh&I (%&\$	%
Fci YhY XY WUjY	Fci YhY XY WUjY		%
6*	H VY WUff %' I &	' - \$	&
6' %	H VY WUff %' I &	' - \$	&
6%&	H VY WUff %' I &	(((\$	&
6%&	H VY WUff %' I &))	&
6&%"	H VY WUff %' I &	' - \$,
6&*&	H VY WUff %' I &))	(
7%	H VY WUff %' I &	%)	&
7&	H VY WUff %' I &	%\$	&
7'	H VY WUff %' I &	, \$	&
9Wci	9Wci A %' Vfi h		&
9Wci	9Wci A %' Vfi h]j Yfgf		&
h[Y ZYhfY	h[Y ZYhfY < %	%+\$	&
h[Y ZYhfY	h[Y ZYhfY < %' dUg]j Yfgf	%+\$	&
8%	H VY WUff %' I &	%+\$	%
8&	H VY WUff %' I &	&*)	(
8(#cei c]g8(%
8)	7c fb], fY &' I &' I "	+\$	&
8*	H VY WUff %' I &	%&\$	%
8+	H VY WUff %' I &) \$\$	%
9%	H VY WUff %' I &	%\$- \$	&
9&	H VY WUff %' I &)*	&
9'	:Yfd'Uh&\$I (+\$,

Bš	8fgl[bUhc b	@b[i Yi f	E hf
: %	:Yfd'Uh(\$I)	%(\$	%
fYggcfh	FYggcfh('fUWhcb %I %I , \$		%
: %	H VY WUff %' I &	&) \$	&
: &	A cmYi 'dfXU]Yf		%
: '	H VY WUff %' I &	' \$\$	%
: (H VY WUff %' I &	&\$	%
>%%	H VY WUff %' I &	*	%
>%&	H VY WUff %' I &	&) \$	%
gl, [Y	G, [Y] f'c' Wci Wf		%
>&%	H VY WUff %' I &	&) \$	%
%%	H VY WUff %' I &	' \$\$	%
%&	H VY WUff %' I &	-)	&
%"	:Yfd'Uh&I (,	&
%)	:Yfd'Uh&I (,	%
%(H VY WUff %' I &) \$	%
6fc WY d]YY ,	fHf fcbX < ,	%&\$	%
Fci YUff], fY %	Fci YUff], fY %		&
dci Wg			
5IY fci Y	5IY Fci Y		(
7ci fcbbY	7ci fcbbY a chc (&\$ (, XYbtrg		'
W VY ZY]b	7 VY XY ZY]b		%
[U]bY ZY]b	: U]bY ZY]b		%
@% (H VY WUff %' I &	(\$	(
W j YHfY	Yi 'XY X]fYWhcb		(
@%&	H VY WUff %' I &)) \$	&
Jlg<YIU[cbUY	Jlg\YIU[cbUY A %' I) \$		&
@%"	:Yfd'Uh(\$I)	*\$	(
@%&	:Yfd'Uh(\$I)	- \$	(
@% (H VY WUff %' I &	& \$	&
@%*	H VY WUff %' I &	(\$ \$	%
@%+	:Yfd'Uh&\$I (, \$	&
5a cfhgYi f	5a cfhgYi f		&
@%&	H VY WUff %' I &	%(\$	(
@%&	H VY WUff %' I &	%(\$	(
@%"	H VY WUff %' I &	% \$	&
Jlg7<7	Jlg7<7 , I &		%&
Jlg<YIU[cbUY	Jlg\YIU[cbUY A , I ")
9Wci	9Wci A , Ui hc ZY]bf		*
; ci d]Y fd]b[Y XfU]Yz%I +\$; ci d]Y fd]b[Y XfU]Yz%I +\$		%
9Wci	9Wci A %' Ui hc ZY]bf		' *
Jlg<YIU[cbUY	Jlg\YIU[cbUY A %' I - \$ D:		'
Jlg<YIU[cbUY	Jlg\YIU[cbUY A %' I , \$		%
9Wci	9Wci A %' Ui hc ZY]bf		%(
; ci d]Y ZY]bX i Y	; ci d]Y ZY]bX i Y) I , \$		&
Jlg\YIU[cbUY	Jlg\YIU[cbUY (I %\$		%
FcbXY Y	FcbXY Y < %' gf fY @		&
9Wci	9Wci A %' Ui hc ZY]bf		&
Jlg<YIU[cbUY	Jlg\YIU[cbUY A %' I)		&
Jlg<YIU[cbUY	Jlg\YIU[cbUY A %' I %\$ D:		*
FcbXY Y	FcbXY Y < %\$ gf fY N		+&
FcbXY Y	FcbXY Y < %& gf fY N		%
Jlg<YIU[cbUY	Jlg\YIU[cbUY A %' I)		%&
Jlg<YIU[cbUY	Jlg\YIU[cbUY A , I +)		%
Jlg<YIU[cbUY	Jlg\YIU[cbUY A %' I + \$ D:		%&
FcbXY Y	FcbXY Y < %\$ gf fY @		(
Jlg<YIU[cbUY	Jlg\YIU[cbUY A %' I) \$ D:		-
Jlg<YIU[cbUY	Jlg\YIU[cbUY A * I "		%
9Wci	9Wci A * Ui hc ZY]bf		%
@	H VY WUff %' I &	%&\$	%
@%"	H VY WUff %' I &	+\$	%
@%&	:Yfd'Uh&\$I (, \$	%
7ffa U], fY gY ffY	7ffa U], fY gY ffY		%
&%	:Yfd'Uh&\$I (, \$	(

Bš	8fgl[bUhc b	@b[i Yi f	E hf
dU]YfWUdYUi	DU]YfWUdYUi <]bH&\$		(
H%	fHf fcbX < &\$	' ' \$	&
H&	H VY WUff %' I &	(, \$	%
H	H VY WUff %' I &	(\$ \$	%
A %%"	H VY WUff %' I &	*\$ \$	%
A %&	H VY WUff %' I &	&) \$	%
8]Zf fY bhY	8]Zf fY bhY		%
B %%"	H VY WUff %' I &	+\$ \$	%
B %&	H VY WUff %' I &	, \$	%
9Wci	9Wci A %\$ Vfi h		%
Jlg<YIU[cbUY	Jlg\YIU[cbUY A %\$ I " \$		&
B %"	:Yfd'Uh(\$I)	% \$	%
d]] bcb	D]] bcb hci fbf		&
dU]YfUdd]ei Y	DU]YfUdd]ei Y		&
C %%"	H VY WUff %' I &	% \$	%
C %&	H VY WUff %' I &	%&\$	%
Fci Y Uj Ubh%+ dci Wg	Fci Y Uj Ubh%+		&
A chYi f	?ha chYi f j f c		%
7ci fcbbY a cX %	7ci fcbbY a chc (&\$ + XYbtrg		%
7ci fcbbY	7ci fcbbY a chc (&\$ (%XYbtrg		&
8ffj] Y WU%Y j f c	8ffj] Y WU%Y j f c		%
7 \U]bY a chc	7 \U]bY a chc)
7 \U]bY j f c	7 \U]bY j f c		&
A Yg fY WU]bY	A Yg fY WU]bY		%
9fUWYi fXY a Ub] Y Yg	9fUWYi fXY a Ub] Y Yg		%
: fY]b { X]gei Yg	: fY]b { X]gei Yg		&
8ffU]Yi fUff], fY	8ffU]Yi fUff], fY		%
7ca a UbXYgXY j hY gYg	7ca a UbXYgXY j hY gYg		%
Dc]] bfY ZY]b j f c	Dc]] bfY ZY]b j f c		'
7 \Ua Vfy { U]f %' dci Wg	7 \Ua Vfy { U]f %' dci Wg		&
8ffj] Y WU%Y a chc	8ffj] Y WU%Y a chc		%
7 \U]f] Yi f VUHY fYg	7 \U]f] Yi f VUHY fYg		%
6UHY fY	6UHY fY		&
D]] bcb gY ffY	D]] bcb gY ffY		%
DUhYUi I j f c	DUhYUi I j f c		%
6c]HYfXY dfXU]Yf	6c]HYfXY dfXU]Yf		%
DfXU]Yg	DfXU]Yg6A L		%
DfXU]Yf	DfXU]Yf		%
G ddcfhZY]b X]gei Y	G ddcfhZY]b X]gei Y		&
7 \Ua Vfy { U]f %' dci Wg	7 \Ua Vfy { U]f %' dci Wg		&
8'	fHf fcbX < &\$	*\$	&
FcbXY Y A chYi f	FcbXY Y A chYi f		%
D%	I D5: %' I %' I %'	') \$	&
D&	I D5: %' I %' I %'	%\$- \$	%
D'	I D5: %' I %' I %'	, - &	%
D(I D5: %' I %' I %'	%(\$	&
D)	:YfXfd'cmf		%
9bhY hc]gY %	H VY WUff %' I &	' \$	&
9bhY hc]gY &	H VY WUff %' I &	' &	(
Jlg<YIU[cbUY	Jlg\YIU[cbUY A %\$ I %\$ D:		(

8(! '6]WmfUWcf
H `Y `f dU]ggYi f) žUW]Yf'G&') ži b]hf `:a a
E i Ubh]hf `:%

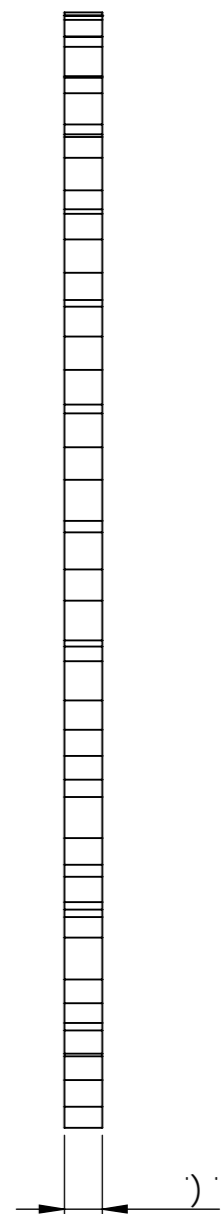
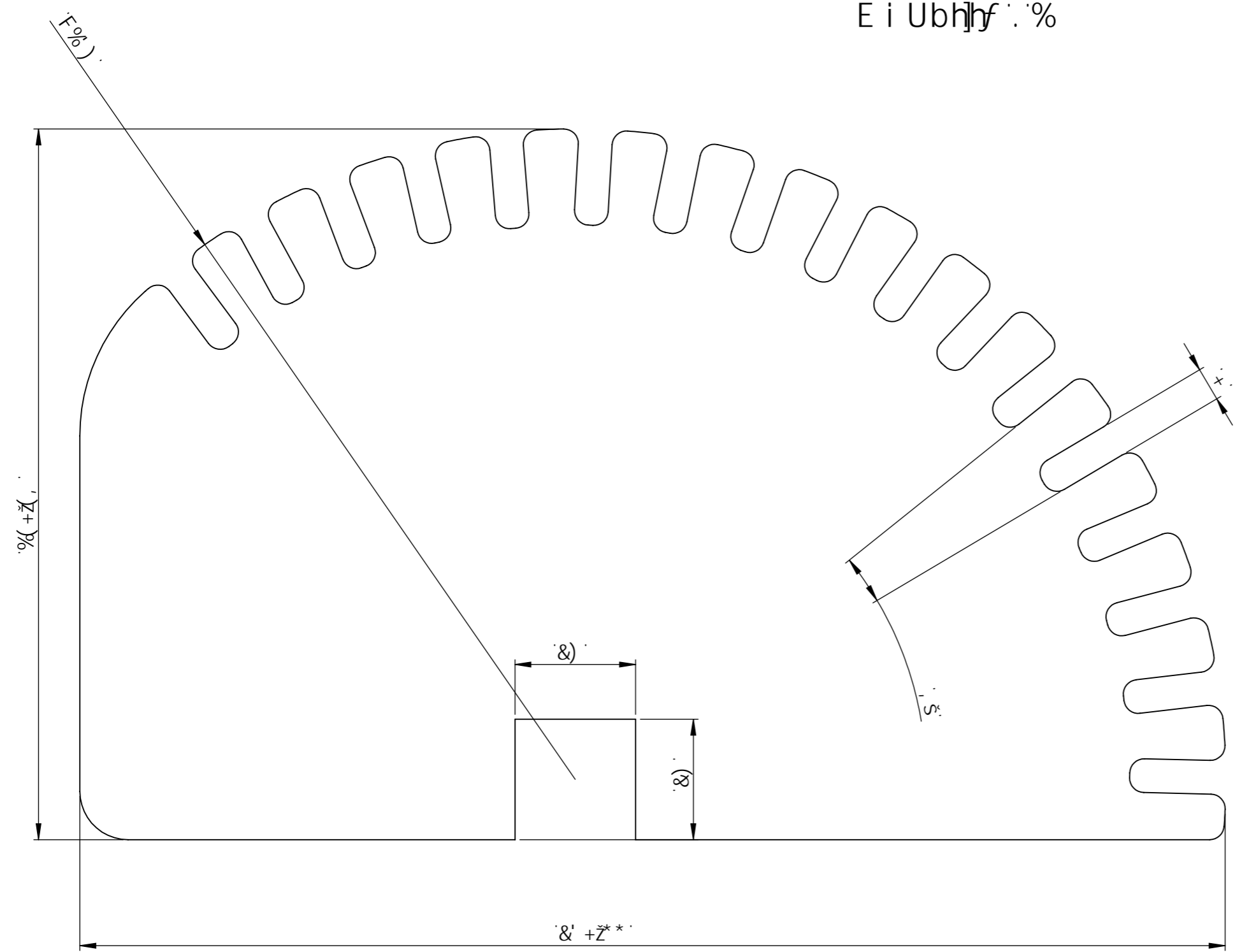

Bš	8fgl[bUhc b	@b[i Yi f	E hf
8(fcnci c]g8(%

5&&! '6]WmfUWcf
 H `Y `f d U]ggYi f) žUW]Y f'G&') ž
 i b]hf `:a a
 E i Ubh]hf `: '&

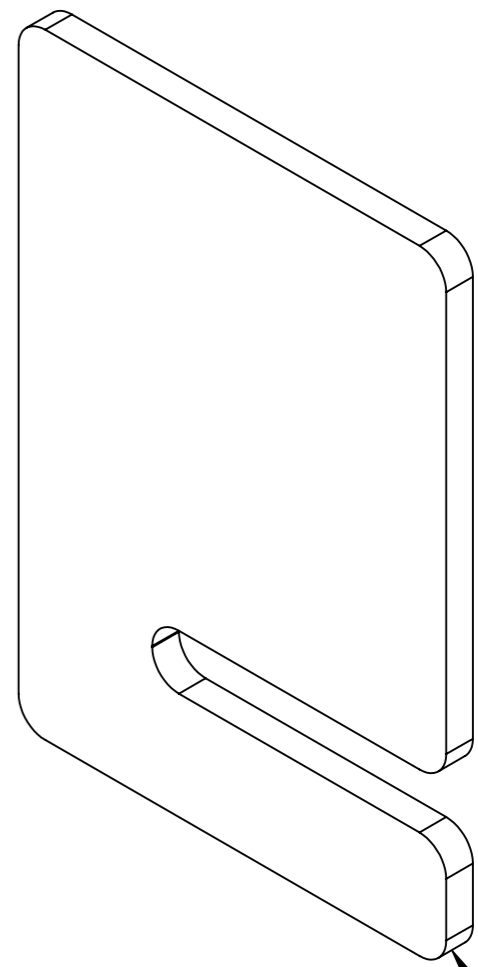
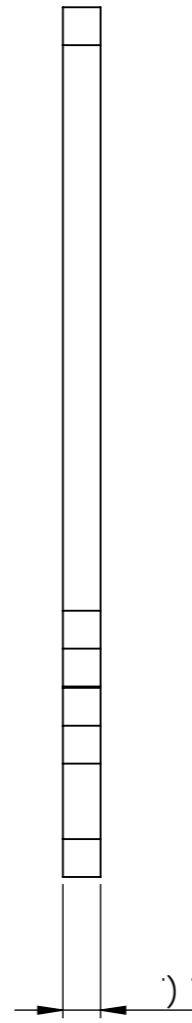
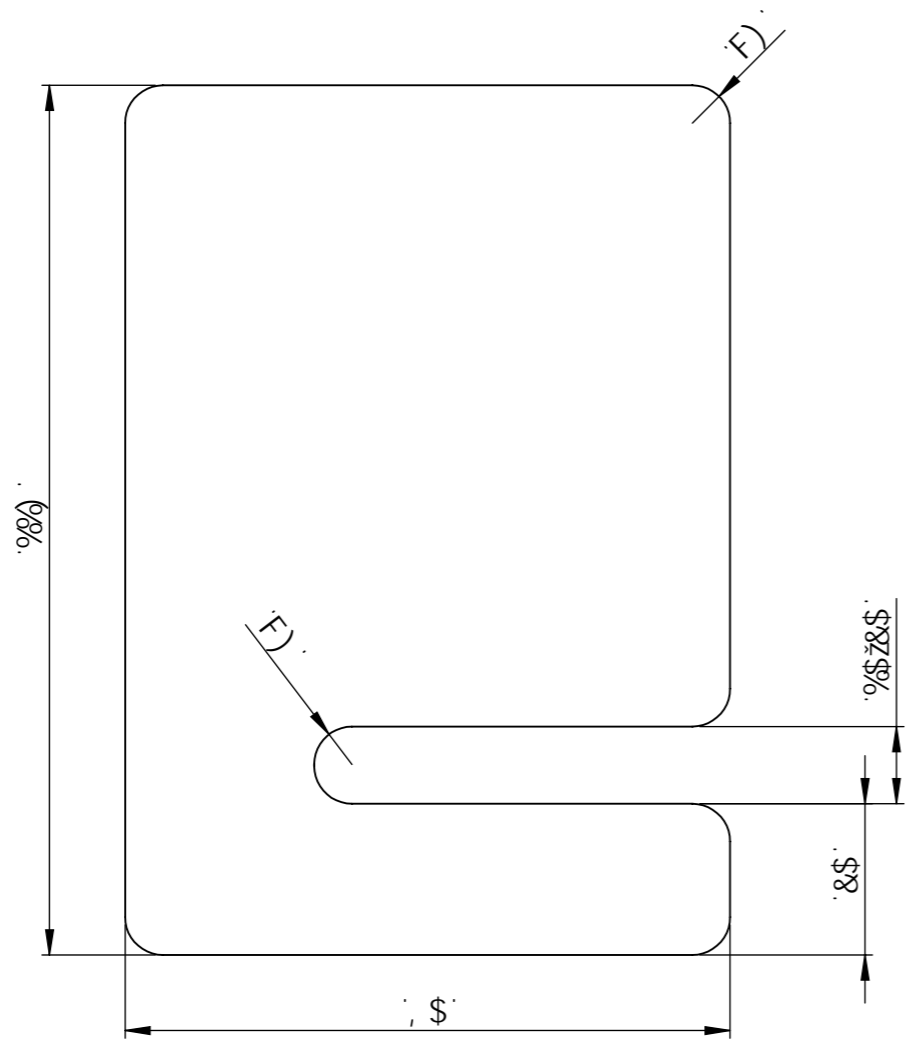

5&&
%

Bš	8fgl[bUh]cb	@b[i Yi f	E hf
5&&	D'Uh]bY `a chYi f		%

5&' !'6]WfUWcf
 H `Y`f dU]ggYi f) žUW]Yf'G&') ž
 i b]hf `:a a

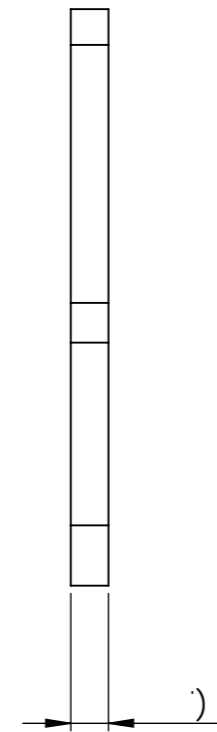
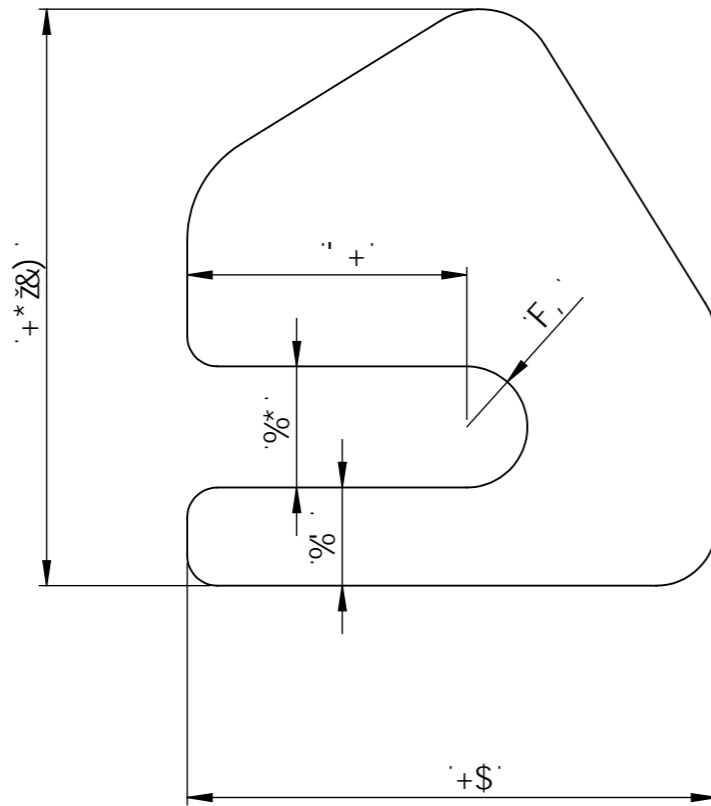
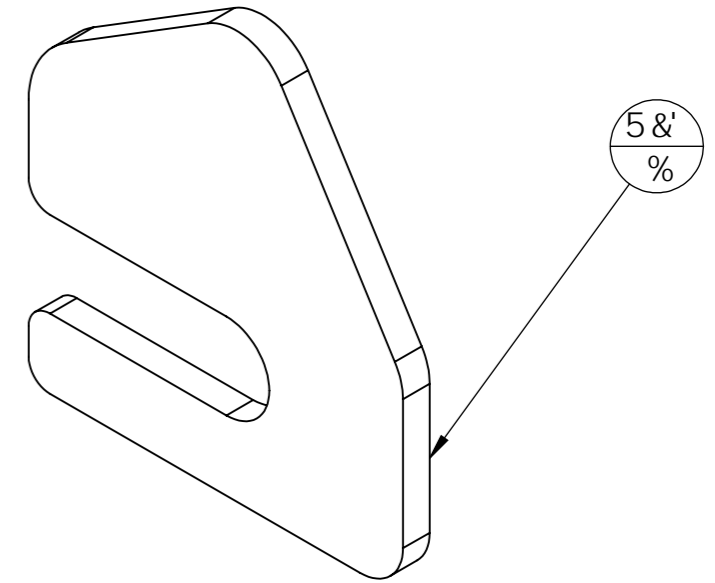

Bš	8fgj[bUh]cb	@b[i Yi f	E hf
5&'	DUh]bY`Zci fW.Y		%

5' ' ! '6]WmfUWcf
H 'Y 'fdU]ggYi f') žUW]Yf'G&') ž
i b]hf ':a a

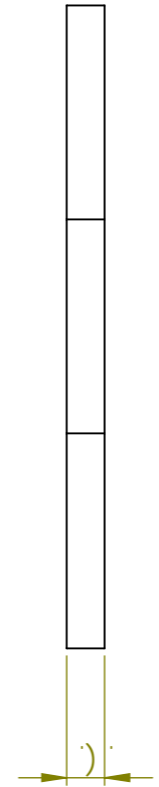
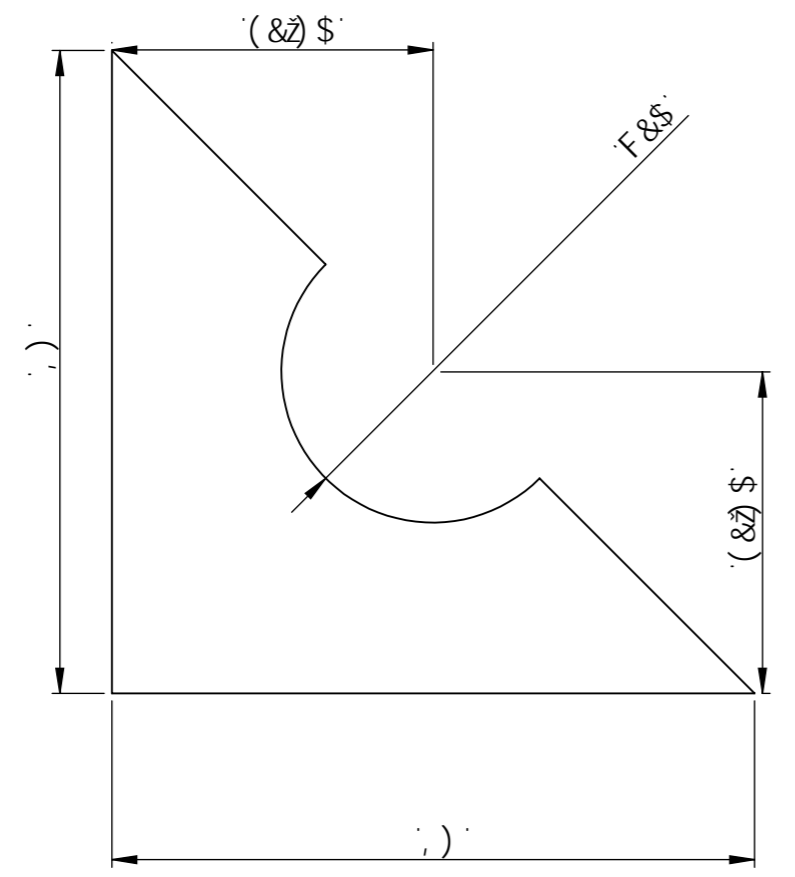
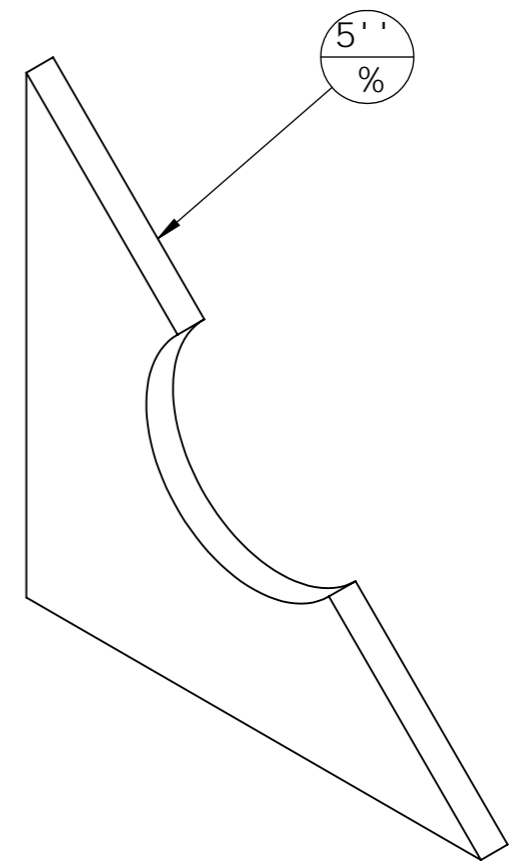

Bš	8fgl[bUhcb	@b[iYi f	E hf
5' '	D'Uh]bY 'X]fYWh]cb '\Ui hY		%

5' (!'6]WĥfUWĥf
 H `Y `f dU]ggYi f) žUW]Yf'G&') ž
 i b]ĥf `:a a

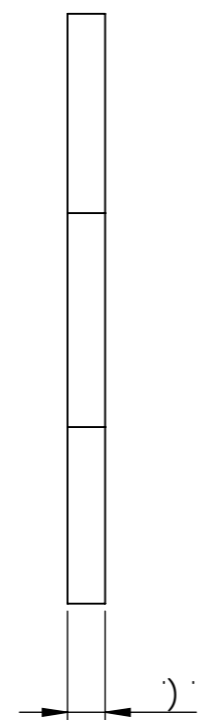
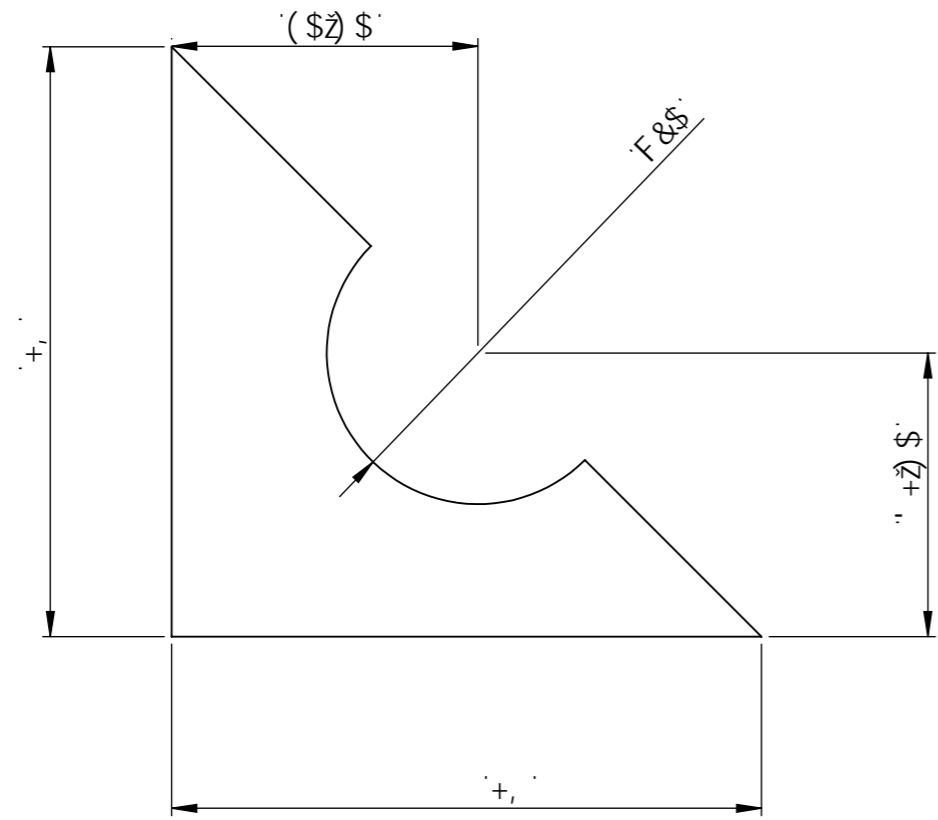
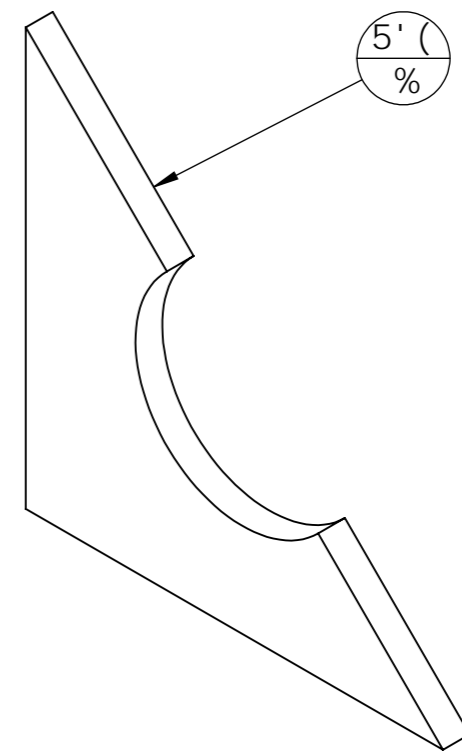

Bš	8fgj[bUĥcb	@b[iYif	E ħf
5' (D`Uĥ]bY `X]fYWĥ]cb `VUggY		%

FcbXY`Y'a chYi f!
 6]WmfUWcf
 H `Y'fdU]ggYi f) žUW]Yf'
 G&') ži b]hf`.'a a

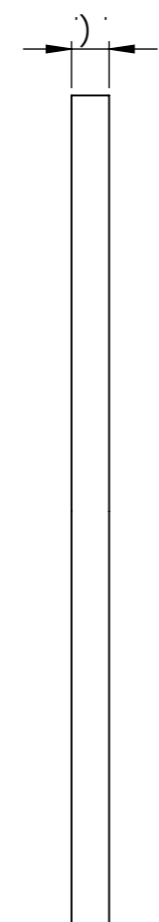
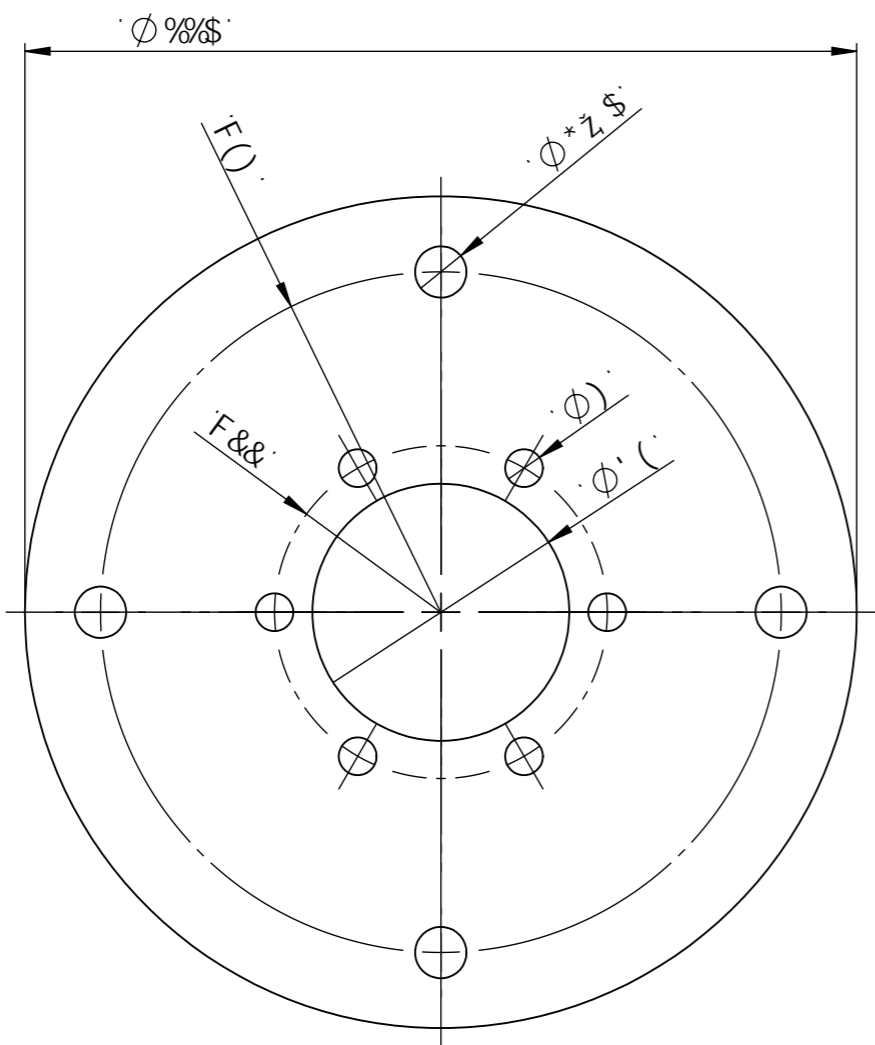
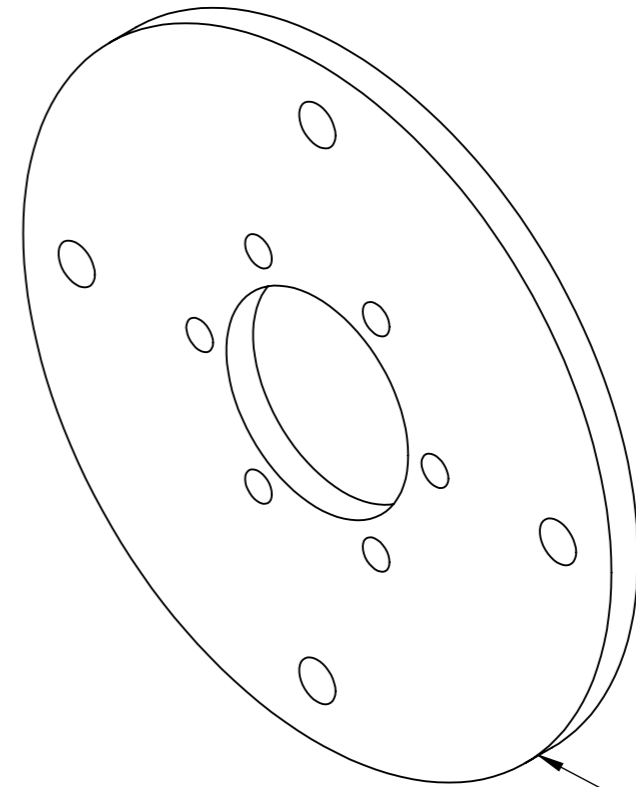

FcbXY`Y'A chYi f
%

Bš	8fgj[bU]cb	@b[i Yi f	E hf
FcbXY`Y'A chYi f	FcbXY`Y'A chYi f		%