

Outil	Chariot de récolte inter-rang				
Date	30/10/2020	Version	1.0		page n° 1 / 5
Feuille	Feuille1				



Table de nomenclature(restructuré)

repère	Désignation	ANGLE1	ANGLE2	p	LONGUEUR	Quantité
A1	Tube carré 25 x 2	23	22		740	2
A12	Cornière 20 x 20 x 3	45	45		410	4
A13	Cornière 20 x 20 x 3	45	45		610	4
A14	té 30 x 30 x 4	0	0		570	1
A2	Tube carré 25 x 2	23	22		380	1
A3	Tube carré 25 x 2	0	0		410	1
A4	Tube carré 25 x 2	22	23		57	4
A5	Tube carré 25 x 2	22	23		380	1
A7	Tube carré 25 x 2	0	0		450	4
A8	Fer plat 30 x 5	0	0		460	2
A9	fer plat 25 x 3	0	0		570	1
B1	Tube rond 20 x 2	0	0	1x Ø16 ; 2x Ø14 ; 4x Ø5 ;	385	1
B2	Tube carré 25 x 2	0	0	2x Ø14 ;	190	1
B3	Tube carré 25 x 2	37	0		128	1
B4	Tube carré 25 x 2	37	0		128	1
B5	Tube carré 25 x 2	0	37		843	1
B6	Tube carré 25 x 2	0	37		843	1
B7	tube rond 30 x 2	0	0	1x Ø26 ;	150	2
B8	Fer plat 30 x 5	14	14		275	1
C1	Tube rond 20 x 2	0	0	1x Ø14 ; 4x Ø5 ;	464	1
Coussinet Øext16 Øint14 L17	palier plastique collerette d14 D16 L17					2
D1	Tube carré 25 x 2	0	0		423	1
D2	Tube rond 20 x 2	0	0		25	1
Ecrou	Ecrou M14 autofreiné					1
Ecrou	Ecrou M8 autofreiné					2
Goupille clips demi lune	goupille clips demi lune Ø4.5x32mm					4
Rondelle	Rondelle Ø14 série MU					1
Rondelle	Rondelle Ø20 série LU					18
Roue 260	Roue gonflable Ø260 ; I85					4
Vis Hexagonale	vis hexagonale M8 x 35					2
Vis Hexagonale	Vis hexagonale M14 x 80					1



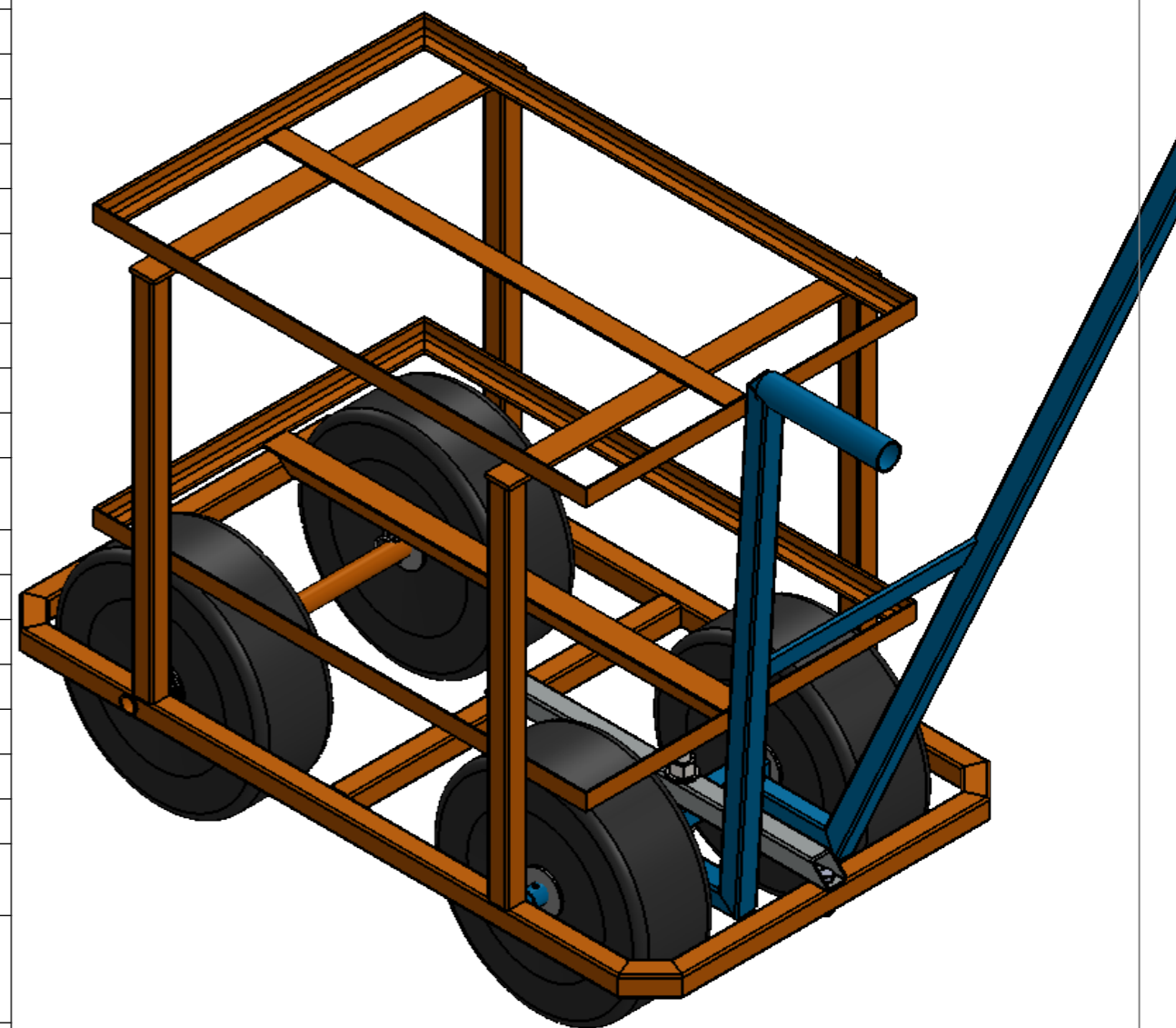
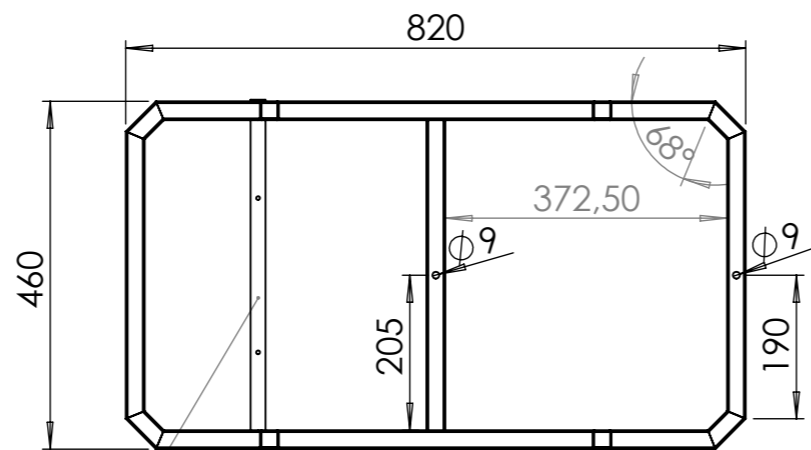
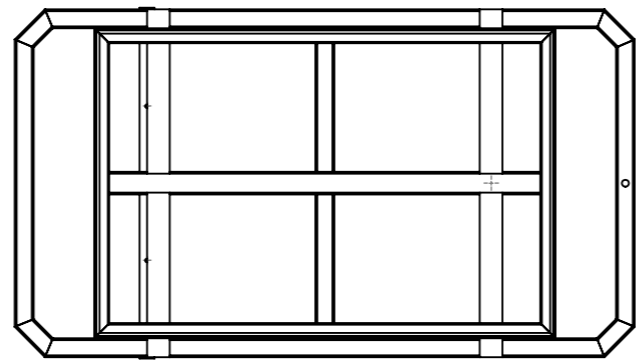
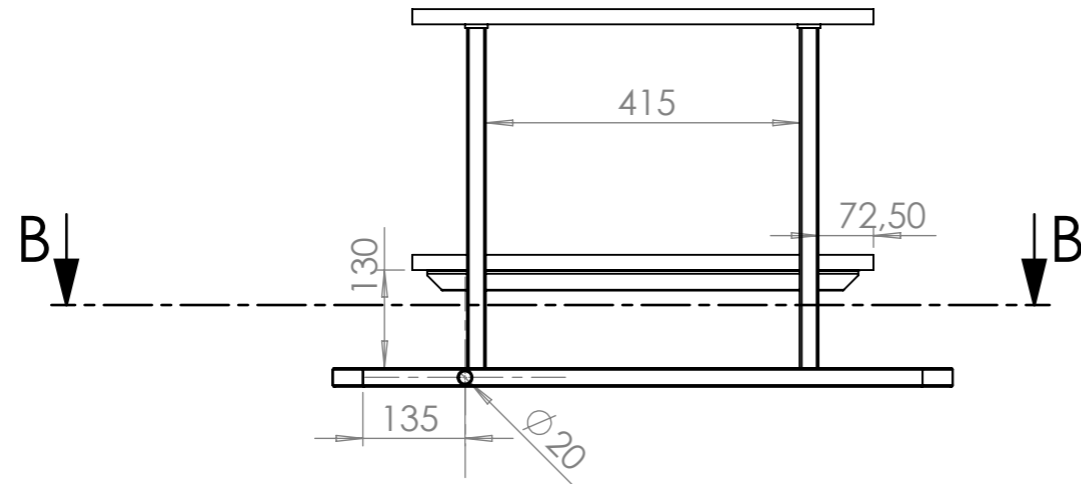
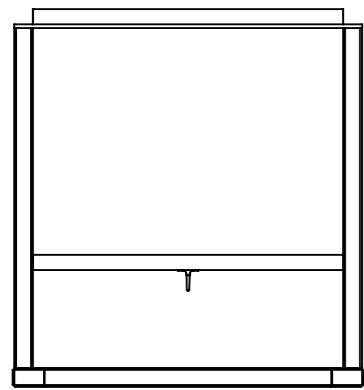

C1 n'est pas soudé au reste

COUPE B-B

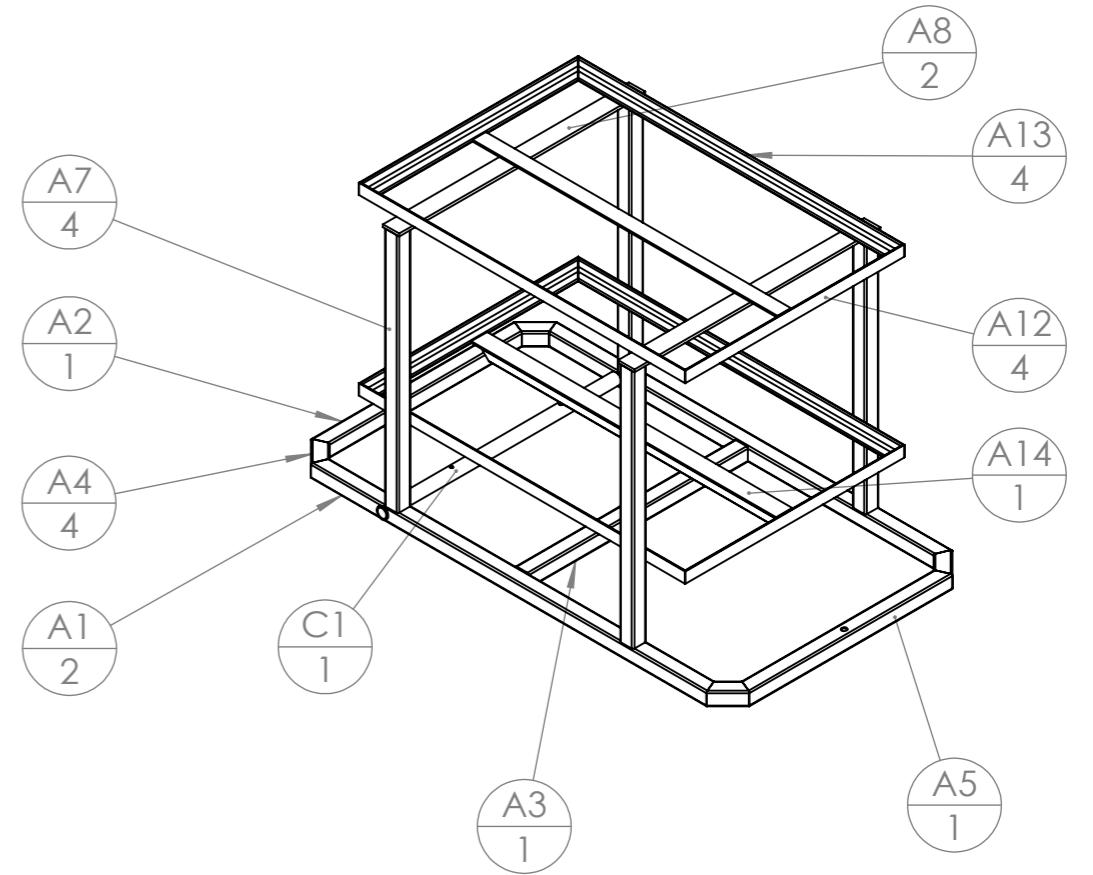

ID	Description	Longueur	Qté
A12	Cornière 20 x 20 x 3	410	4
A13	Cornière 20 x 20 x 3	610	4
A1	Tube carré 25 x 2	740	2
A4	Tube carré 25 x 2	57	4
A2	Tube carré 25 x 2	380	1
A3	Tube carré 25 x 2	410	1
C1	Tube rond 20 x 2	464	1
A7	Tube carré 25 x 2	450	4
A8	Fer plat 30 x 5	460	2
A9	fer plat 25 x 3	570	1
A5	Tube carré 25 x 2	380	1
A14	té 30 x 30 x 4	570	1

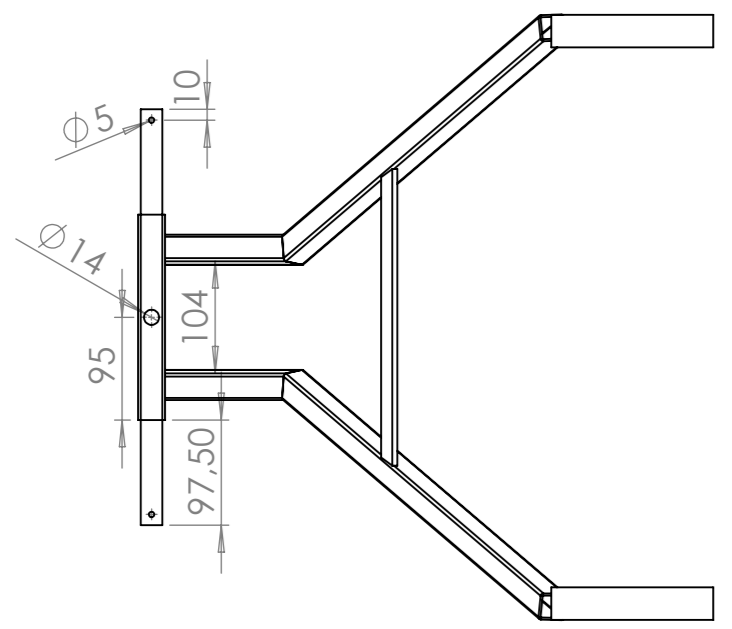
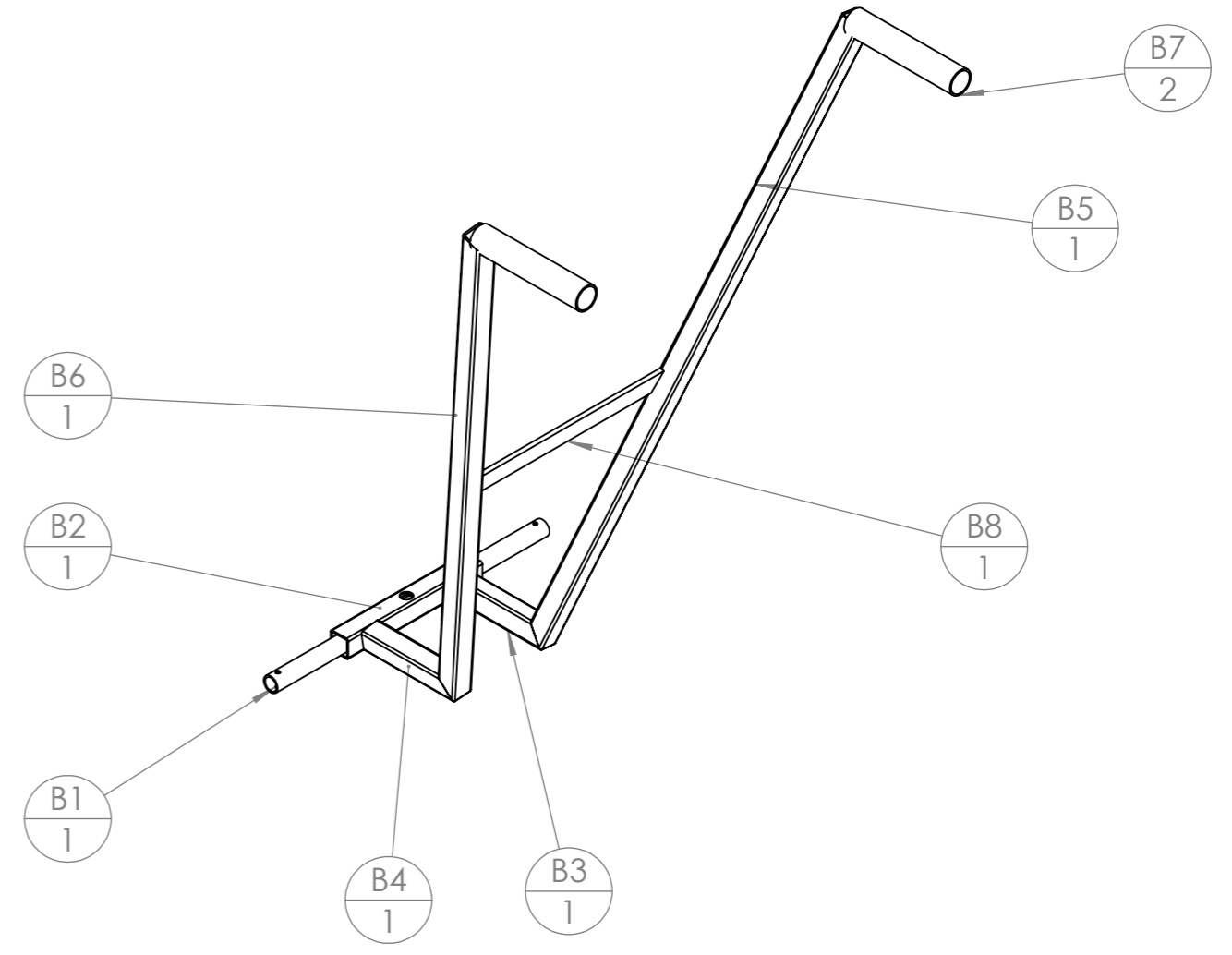
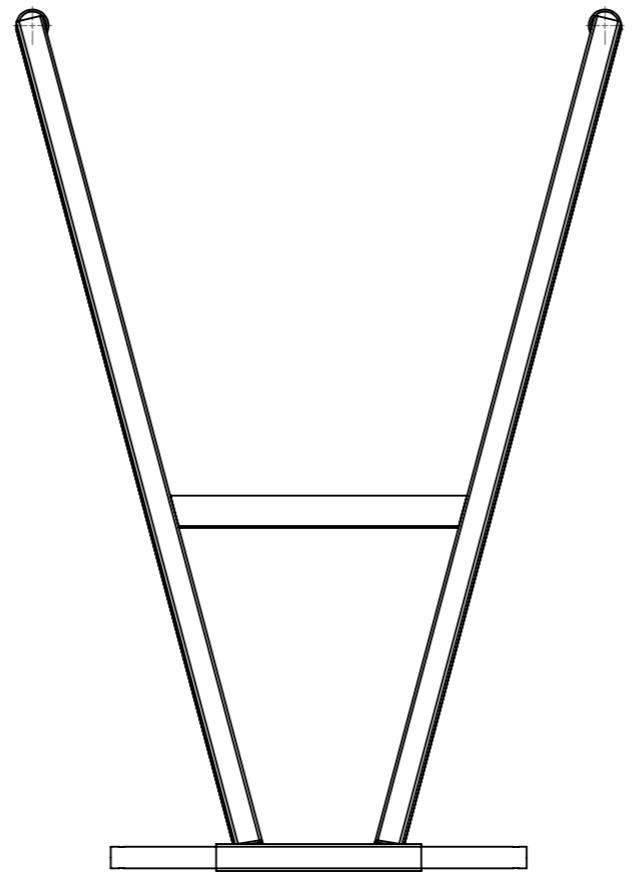
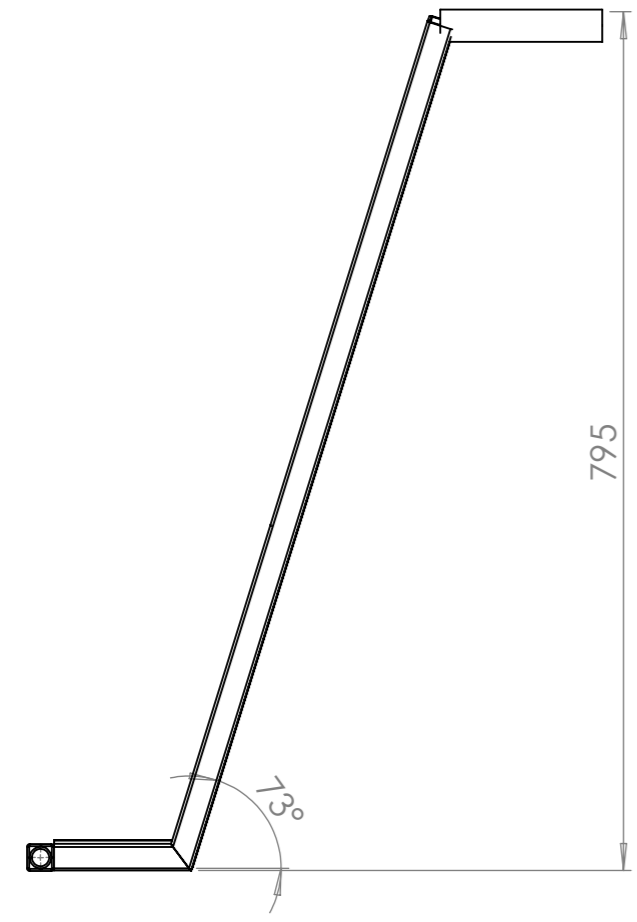

ID	Description	Longueur	Qté
B1	Tube rond 20 x 2	385	1
B7	tube rond 30 x 2	150	2
B5	Tube carré 25 x 2	843	1
B3	Tube carré 25 x 2	128	1
B4	Tube carré 25 x 2	128	1
B6	Tube carré 25 x 2	843	1
B8	Fer plat 30 x 5	275	1
B2	Tube carré 25 x 2	190	1

Outil	Chariot de récolte inter-rang				
Date	30/10/2020	Version	1.0		page n° 4 / 5
Feuille	C - axe roues				

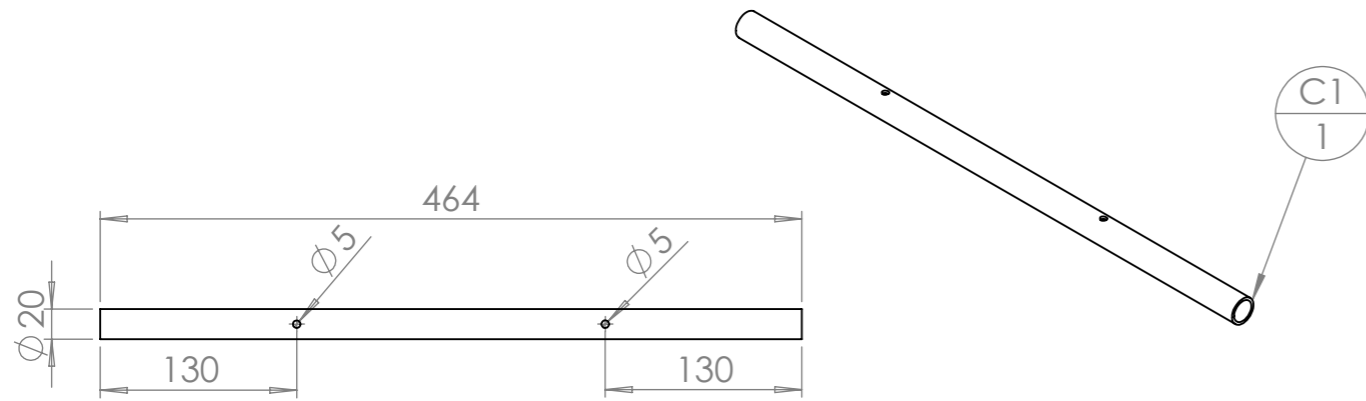

Les trous sont traversants

ID	Description	Longueur	Quantité
C1	Tube rond $\varnothing 20 \times 2$	464	1

Outil	Chariot de récolte inter-rang			<b>L'atelier paysan</b>	
Date	30/10/2020	Version	1.0		page n° 5 / 5
Feuille	D				

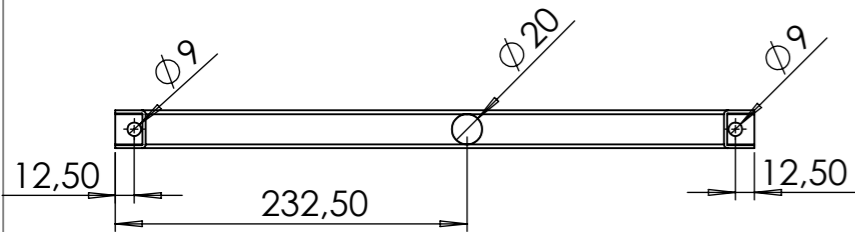
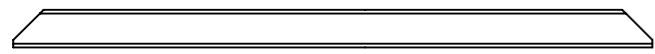
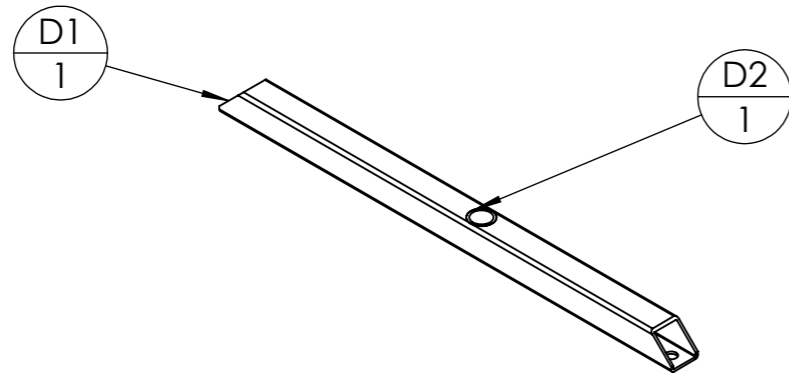

ID	Description	Longueur	Qté
D1	Tube carré 25 x 2	423	1
D2	Tube rond 20 x 2	25	1

### Détails du pivot de direction :

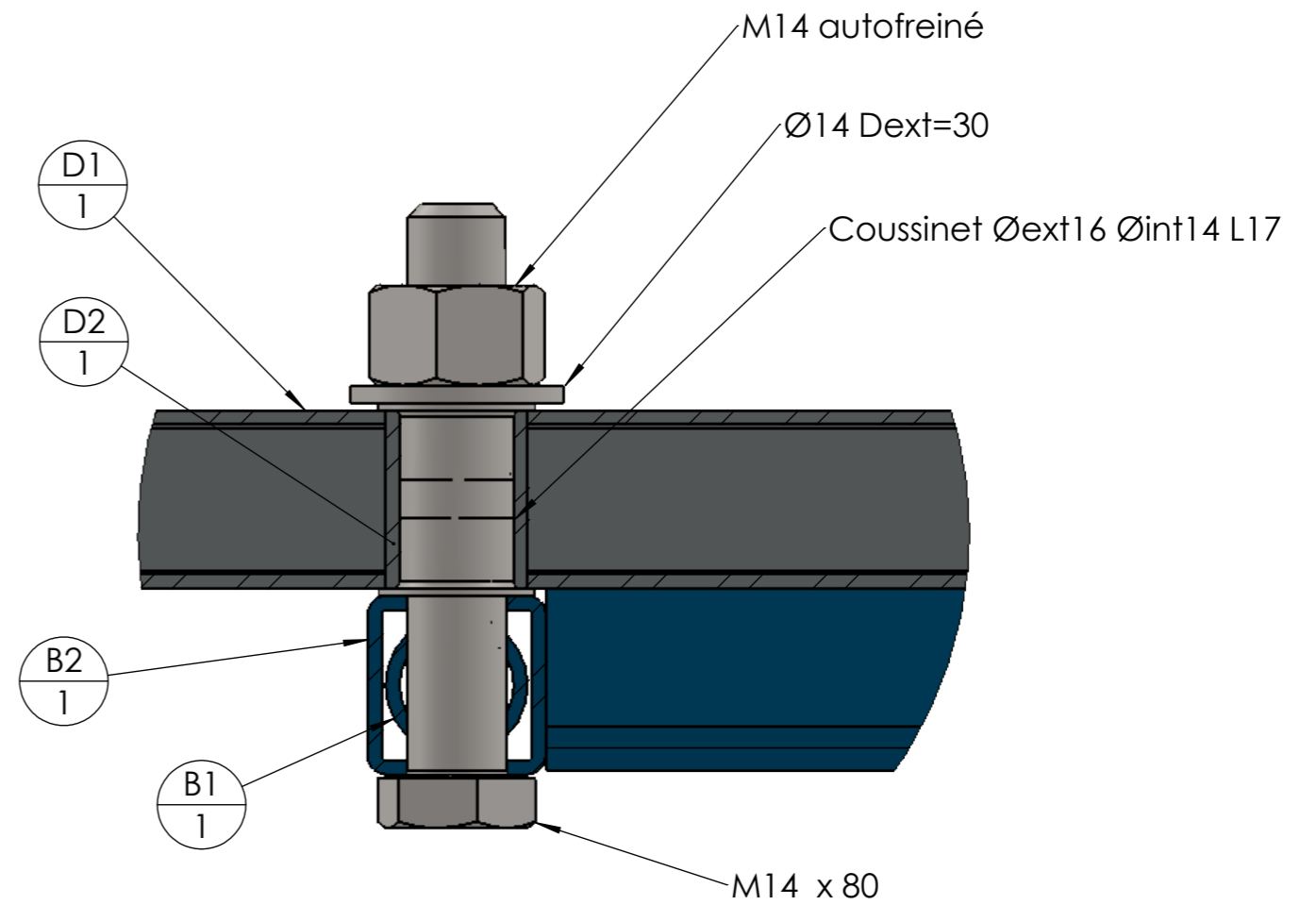

DÉTAIL L  
ECHELLE 1 : 1

Le tube rond Ø20mm D2 est soudé à D1.  
 Les soudures sont à meuler / limer pour pouvoir insérer les bagues IGUS D16 d14  
 Pour pouvoir mettre deux bagues IGUS, il faut les raccourcir de 5mm chacune.  
 La vis M14x80 est soudée au tube carré B2 pour bloquer sa rotation.