

Outil	Relevage Kassine				
Date	04/12/2020	Version	0.1	page n° 1 / 19	
Pièce	Préambule		Qté	1	

Avant de commencer



La présente version est le résultat des évolutions par l'usage, d'expérimentations paysannes quotidiennes, des ajustements pratiques issus des retours des participants aux nombreuses formations et journées de terrain collectives.

L'autoconstruction de votre outil à l'aide de ce tutoriel n'est que le début de votre aventure. Si cette machine est pertinente en l'état pour de nombreux contextes, vous allez devoir l'adapter, la régler, la modifier pour l'ajuster à votre projet agronomique, vos itinéraires techniques, vos conditions pédo-climatiques. Vous allez donc faire vivre cette machine.

Félicitations, vous êtes en passe de devenir constructeur d'outils et machines agricoles homologué CE! Renseignez-vous sur vos responsabilités légales sur notre site: des outils paysans\techniques et réglementations. (<https://www.latelierpaysan.org/Techniques-et-reglementations>)

Merci de nous faire parvenir vos retours, vos découvertes, vos réussites.
Vos expériences individuelles, vos tâtonnements de terrain viendront enrichir le pot commun paysan, sous même licence libre que les présents plans.

<http://www.latelierpaysan.org/>

<http://forum.latelierpaysan.org>

Outil	Relevage Kassine				
Date	04/12/2020	Version	0.1		page n° 2 / 19
Pièce	Nomenclature générale		Qté		1



Pièce	Désignation	basse/Quantité
A	Age	1
B	Levier relevage	1
C	support roue et levier droite	1
C	support roue et levier gauche	1
D	Pivot relevage	2
E	Montant roue	2
F	Poutre relevage	1
G	bride externe	3
H	Croisillon interne	2
I	Poutre arrière	1
J	blocage pivotant	1
K	bride externe	1
L	gâchette	1
Ressort Crochet	ressort traction 12 x 2 x 60	1
Chaîne Ø5	Chaine gâchette	1
Roue	Roue gonflable Ø399 ; 1104 ref FR1400820100	2
Goupille épingle d'axe	Goupille épingle d'axe 25x115 Ø5	2
Goupille clips demi lune	goupille clips demi lune Ø8	2
Ecrou	Ecrou M8 autofreiné	10
Ecrou	Ecrou M10 autofreiné	2
Vis Hexagonale	Vis hexagonale M10 x 60 PF	2
Vis Hexagonale	Vis hexagonale M10 x 20	6
Vis Hexagonale	Vis hexagonale M10 x 110 PF	8
Vis Hexagonale	Vis hexagonale M10 x 170 PF	1
Vis Hexagonale	vis hexagonale M10 x 55	1

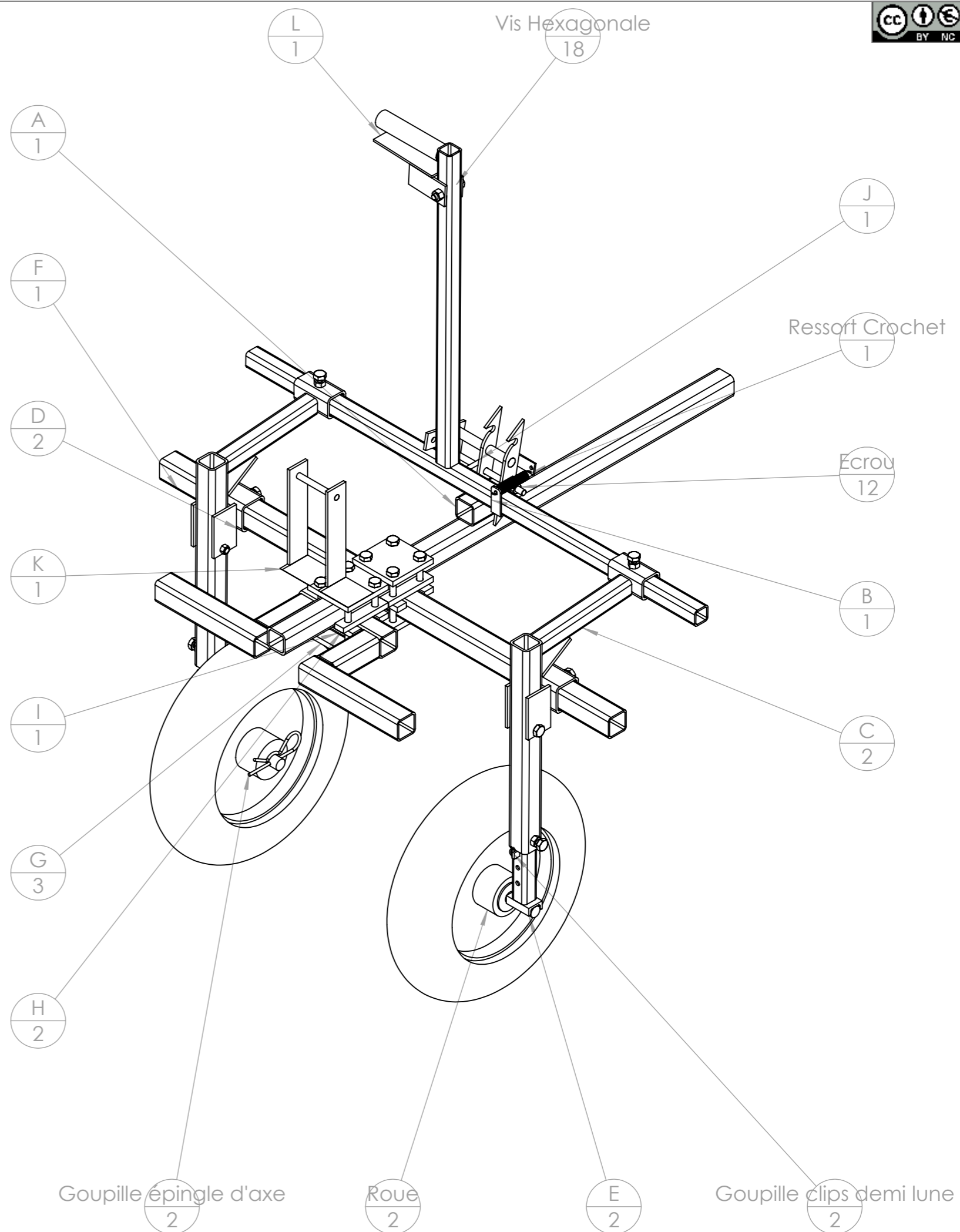

Outil	Relevage Kassine			L'atelier paysan	
Date	04/12/2020	Version	0.1		page n° 3 / 19
Pièce	Encombrement		Qté		1



En position roues basses

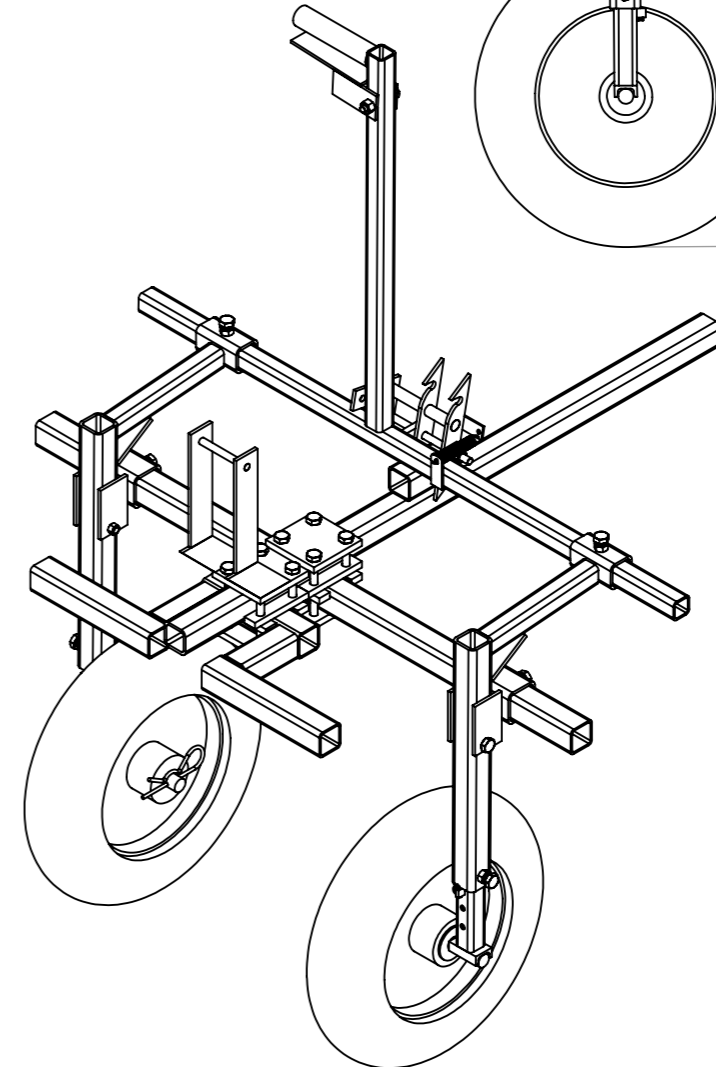
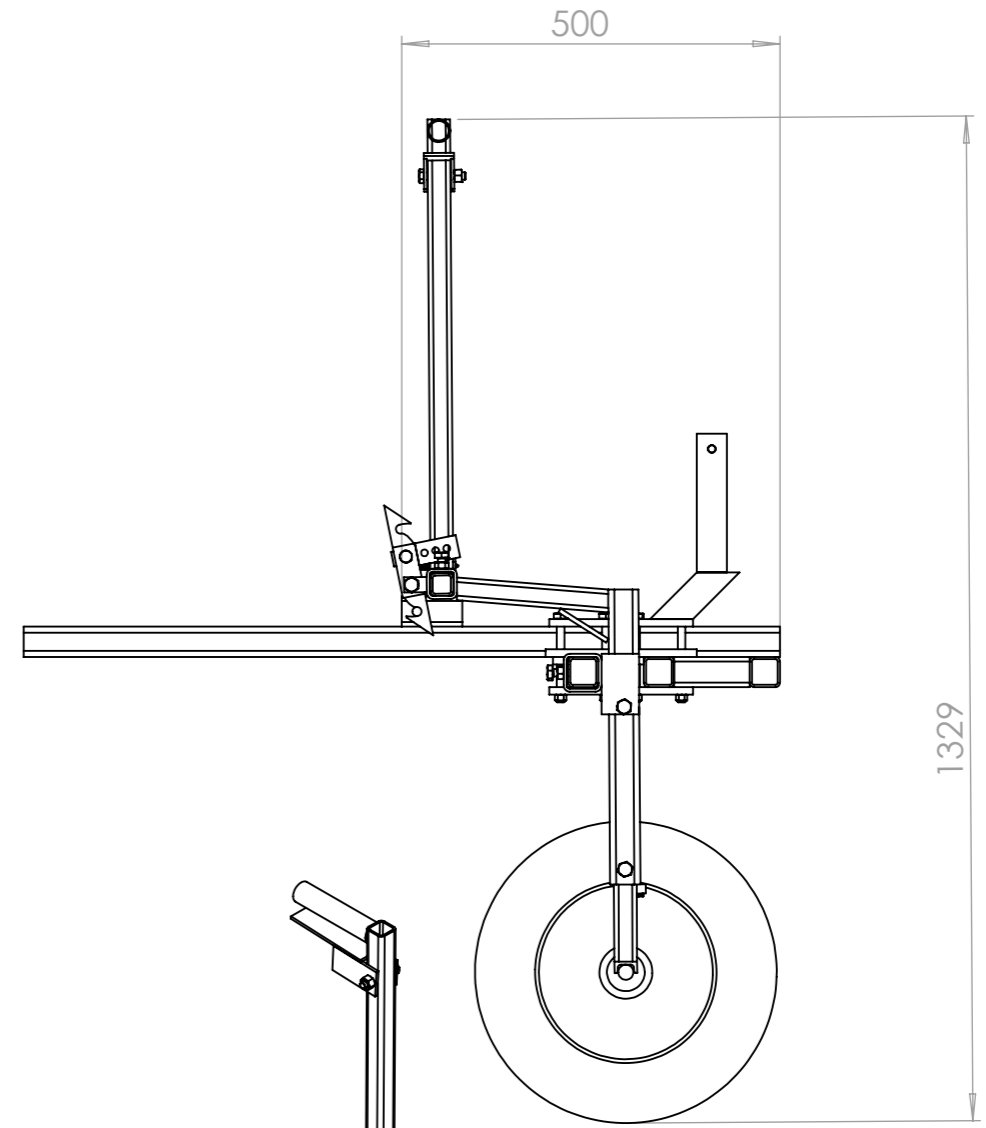
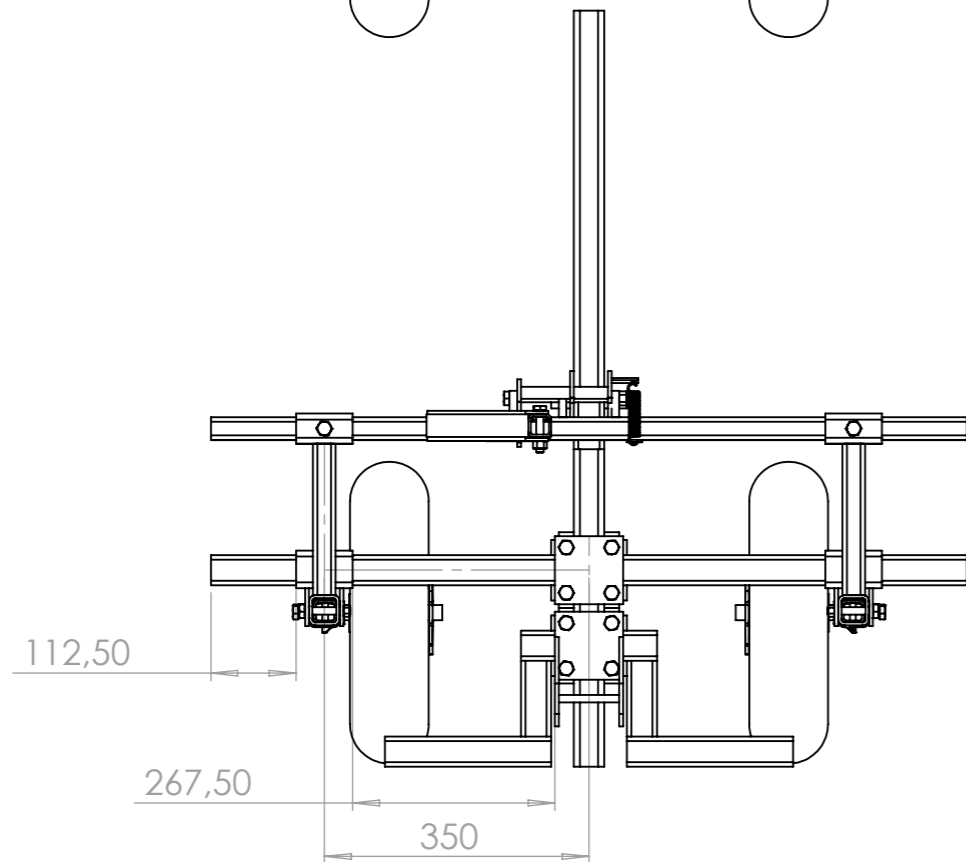
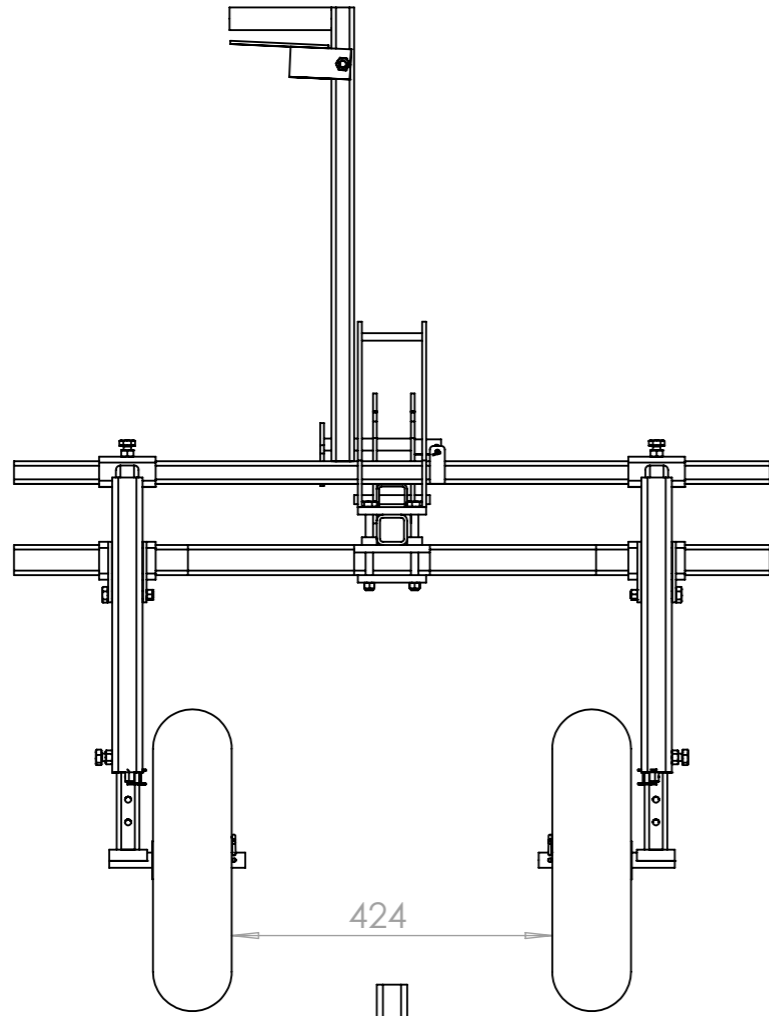

Outil	Relevage Kassine				
Date	04/12/2020	Version	0.1		page n° 4 / 19
Pièce	Eclaté général		Qté		1

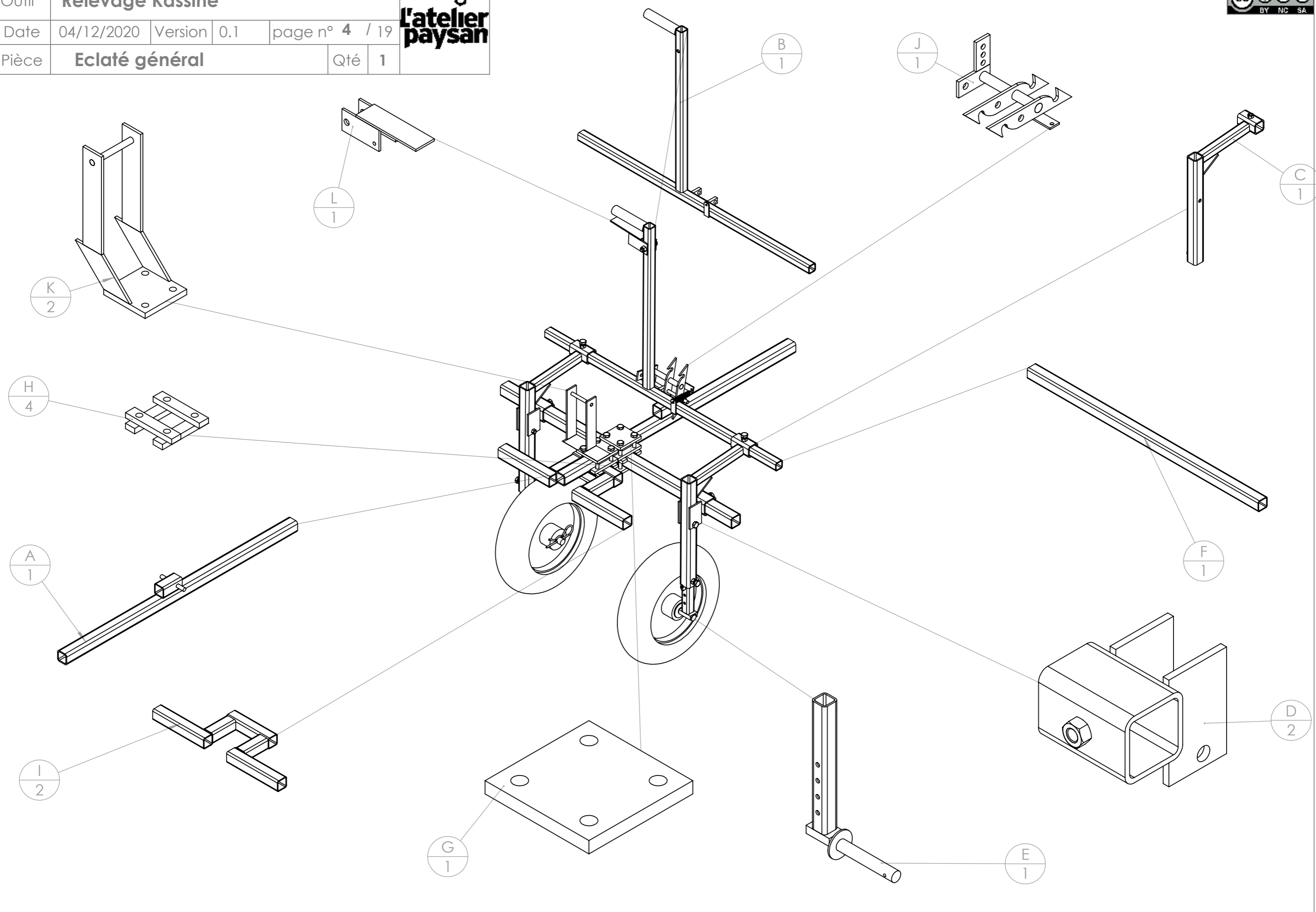

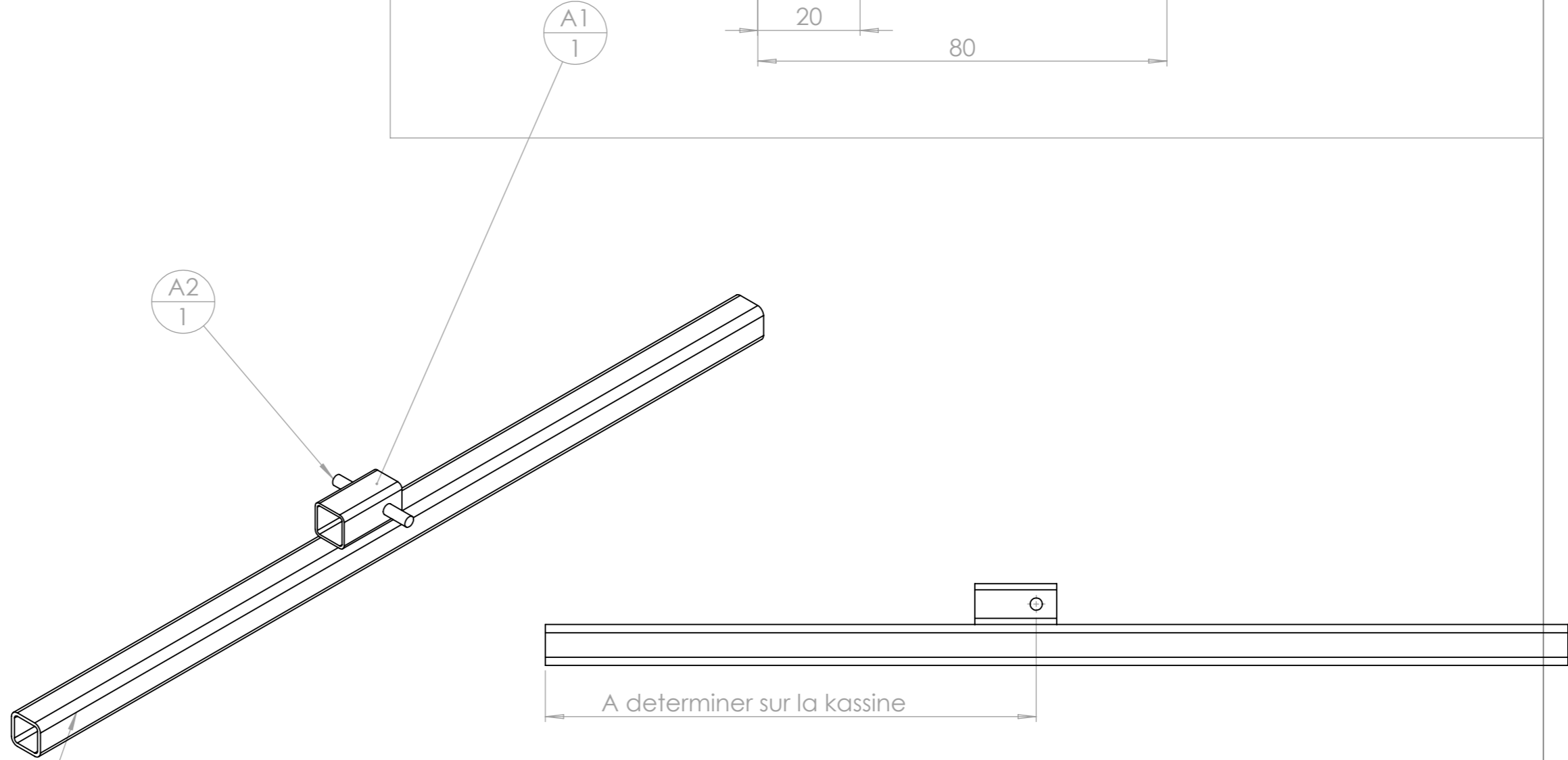
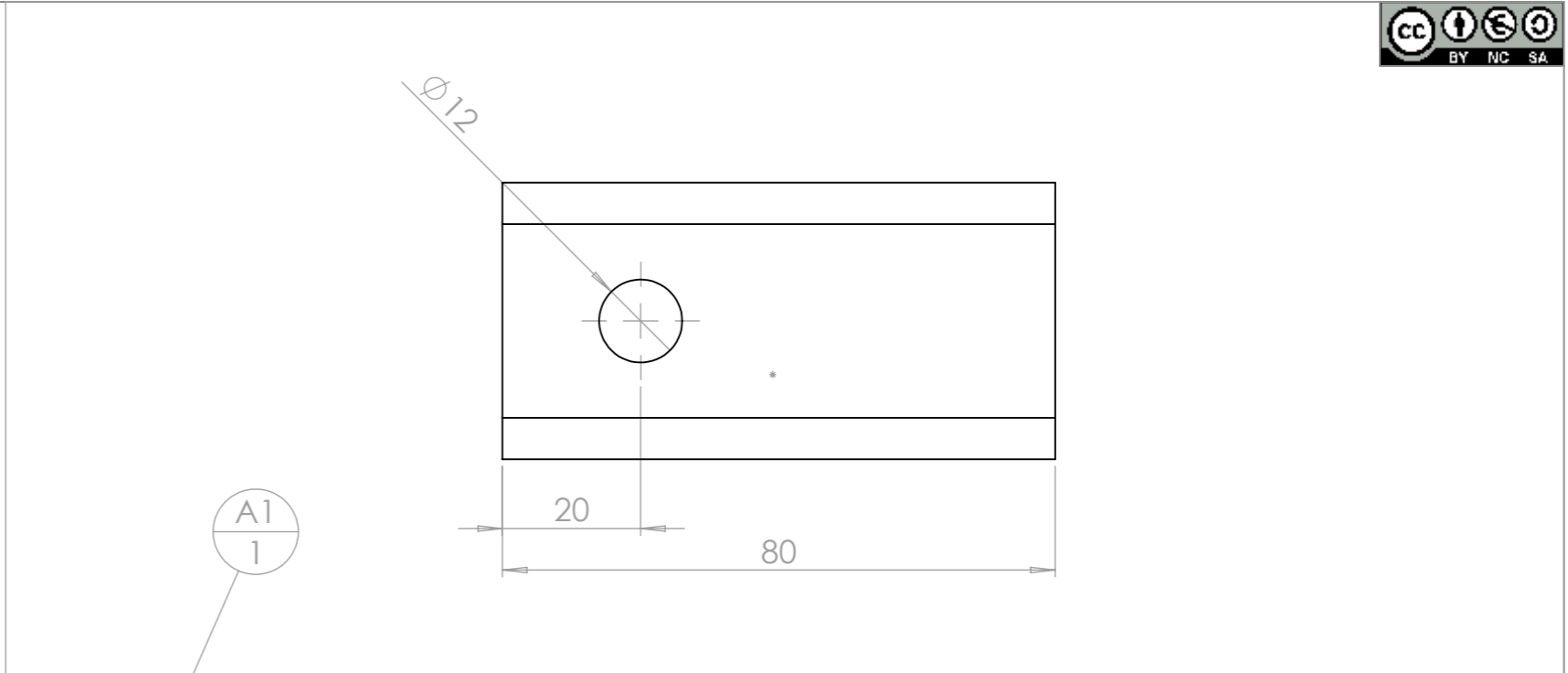

L'Age centrale est celle de la Kassine

ID	Description	ANGLE1	ANGLE2	p	Longueur	Qté
A1	tube carré 40 x 3	0	0	2x Ø12 ;	80	1
A2	Fer rond Ø12	0	0		100	1

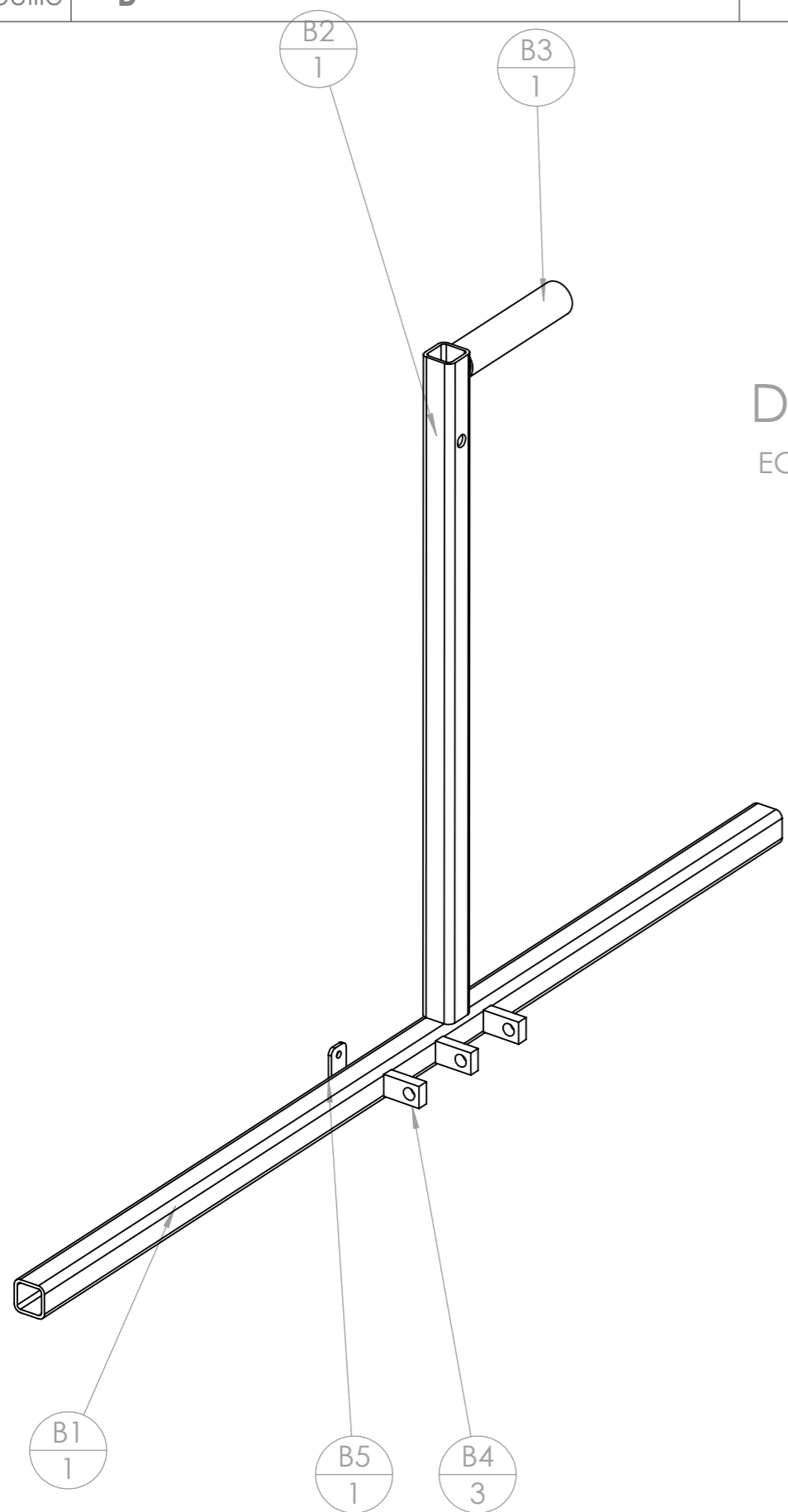

DÉTAIL C
ECHELLE 1 : 1

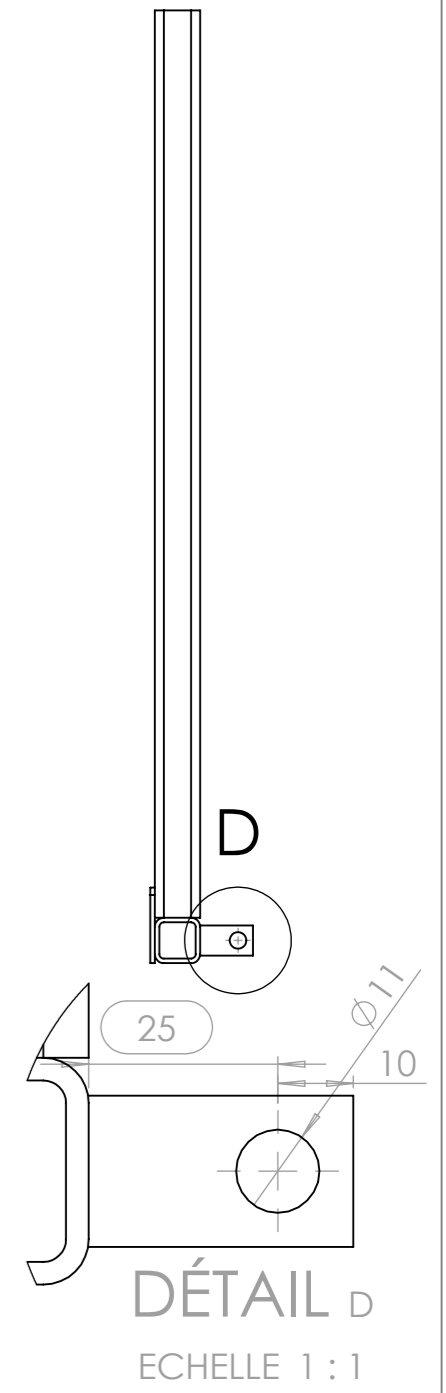
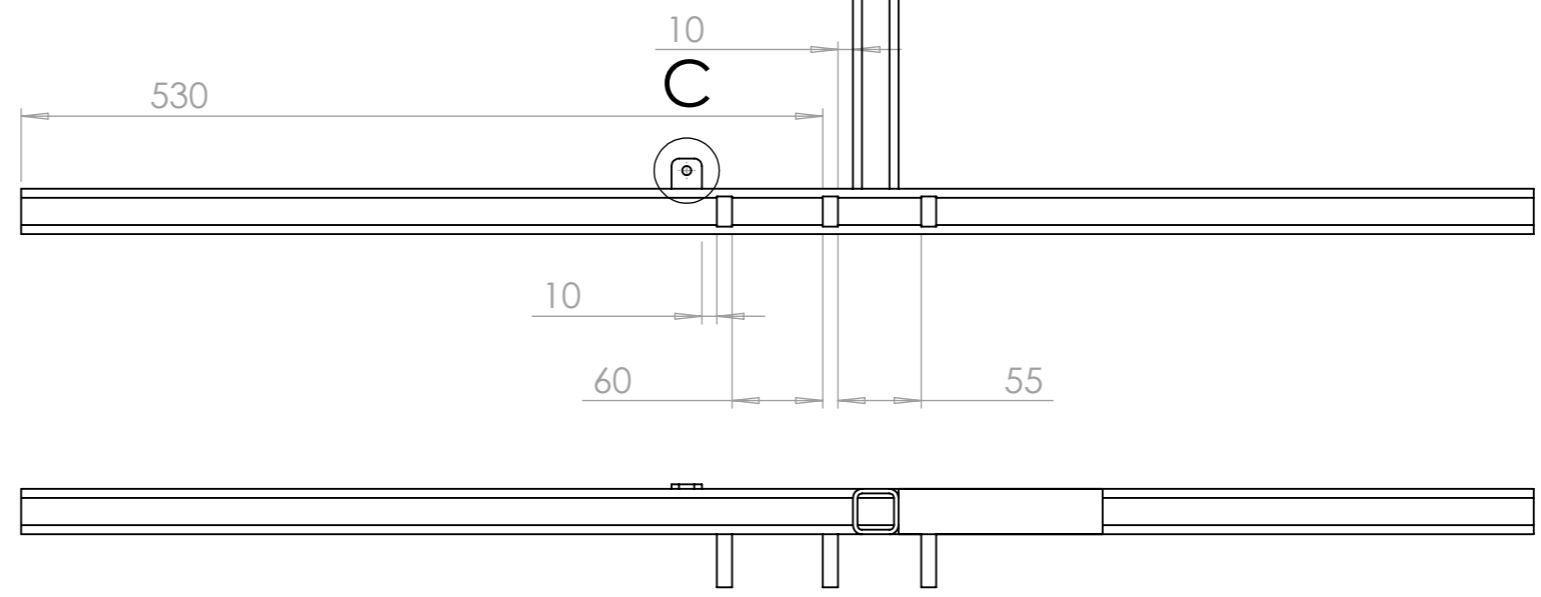
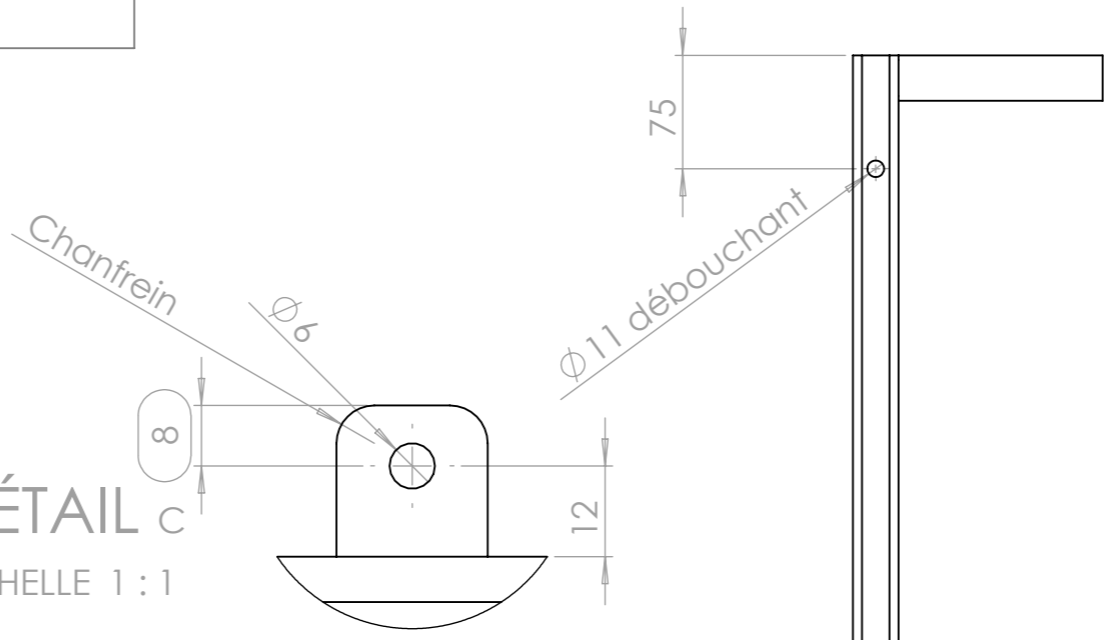

DÉTAIL D
ECHELLE 1 : 1

ID	Description	ANGLE1	ANGLE2	p	Longueur	Qté
B1	tube carré 30 x 3	0	0		1000	1
B2	tube carré 30 x 3	0	0	2x Ø11 ;	600	1
B3	tube rond 30 x 2	0	0	1x Ø26 ;	135	1
B4	Fer plat 20 x 10	0	0	1x Ø11 ;	35	3
B5	Fer plat 20 x 3	0	0	1x Ø6 ;	50	1

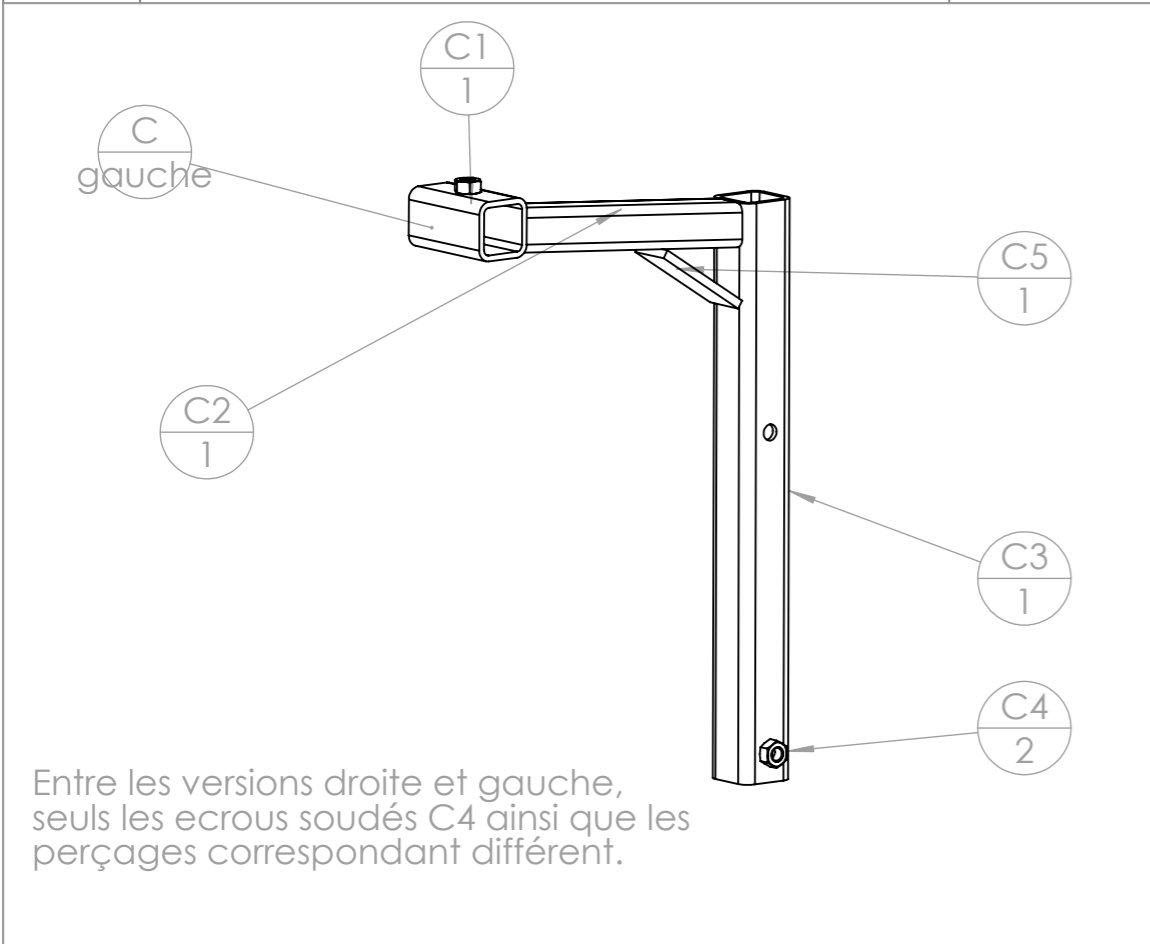

Entre les versions droite et gauche, seuls les ecrous soudés C4 ainsi que les perçages correspondant diffèrent.

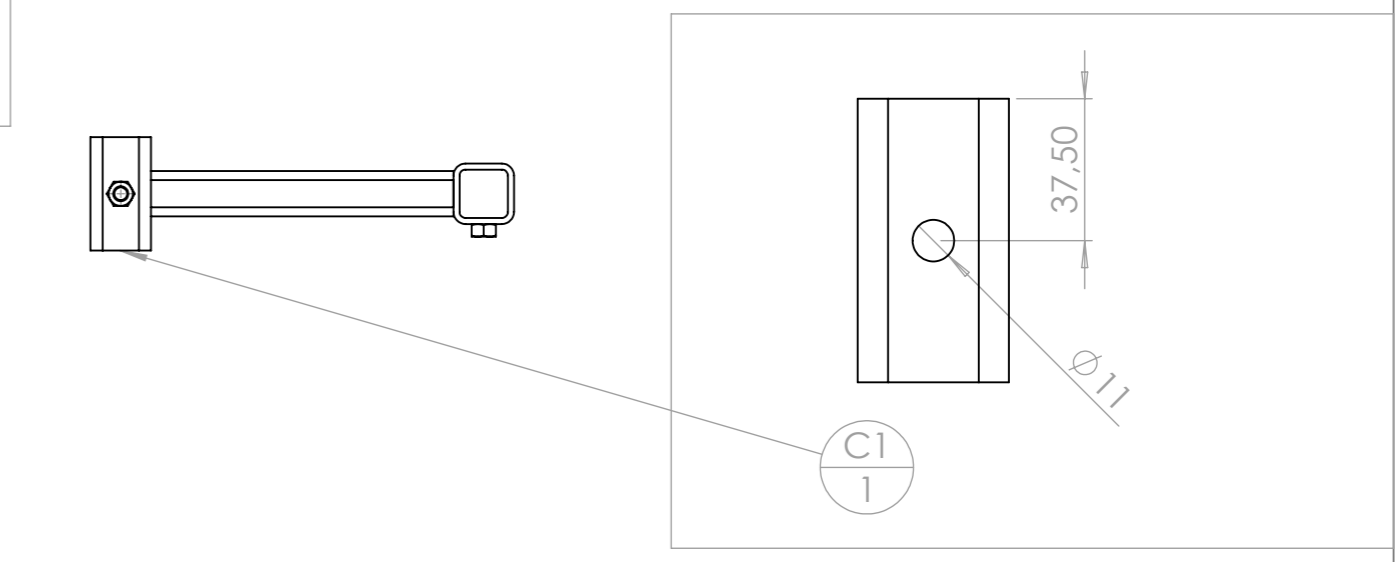
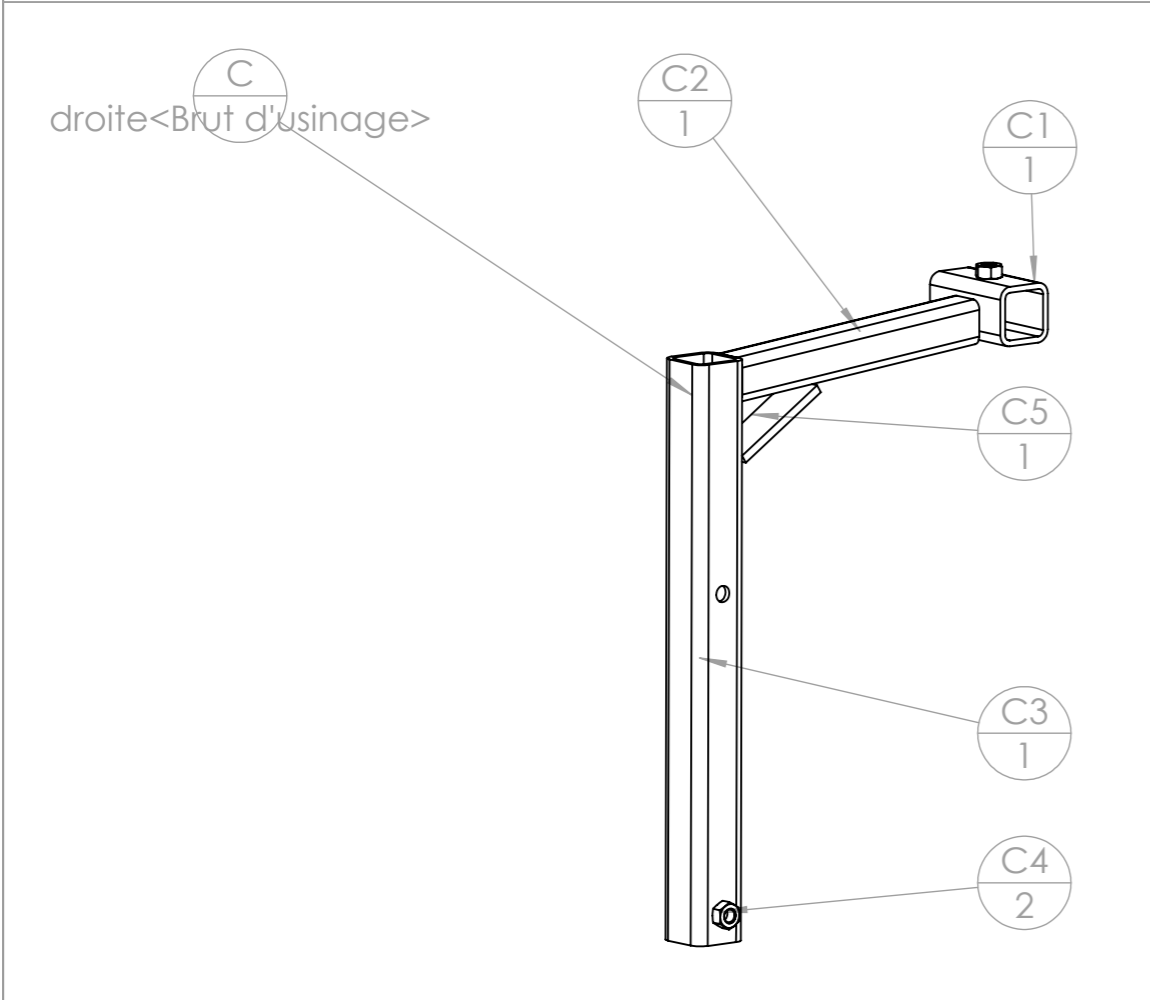
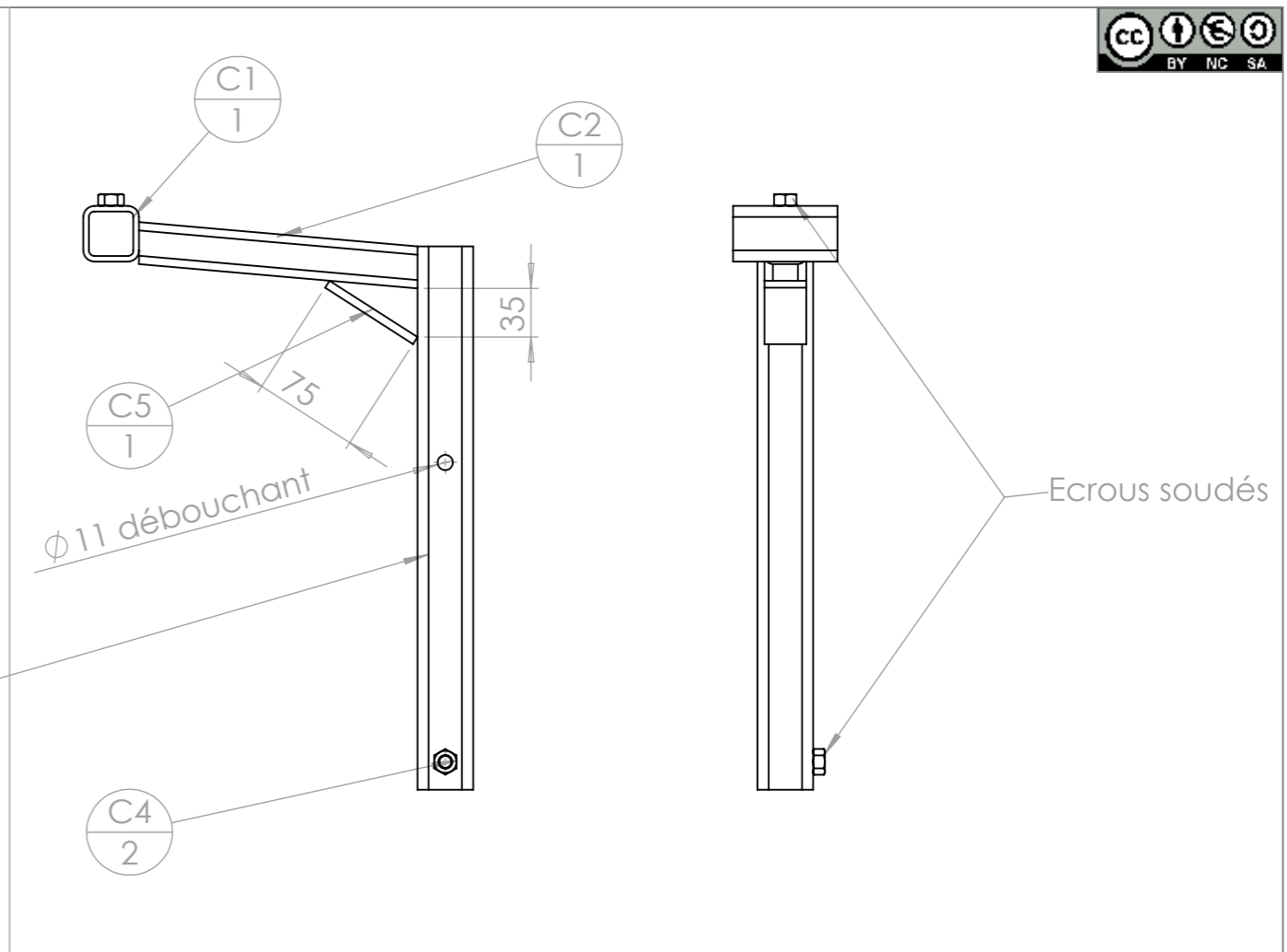
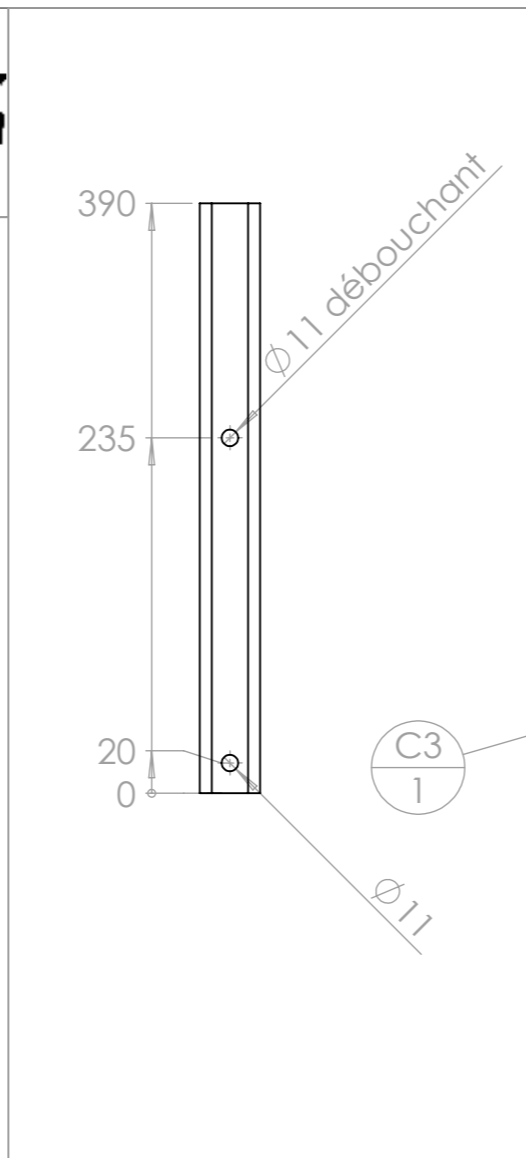

ID	Description	ANGLE1	ANGLE2	p	Longueur	Qté
C1	tube carré 40 x 4	0.00	0.00	1x Ø11 ;	75	1
C2	tube carré 30 x 3	5.00	5.00		203	1
C3	tube carré 40 x 4	0.00	0.00	3x Ø11 ;	390	1
C4	Ecrou M10 brut			1x Ø8,5 ; 2x Ø10 ;		2
C5	Fer plat 30 x 6	0.00	0.00		75	1

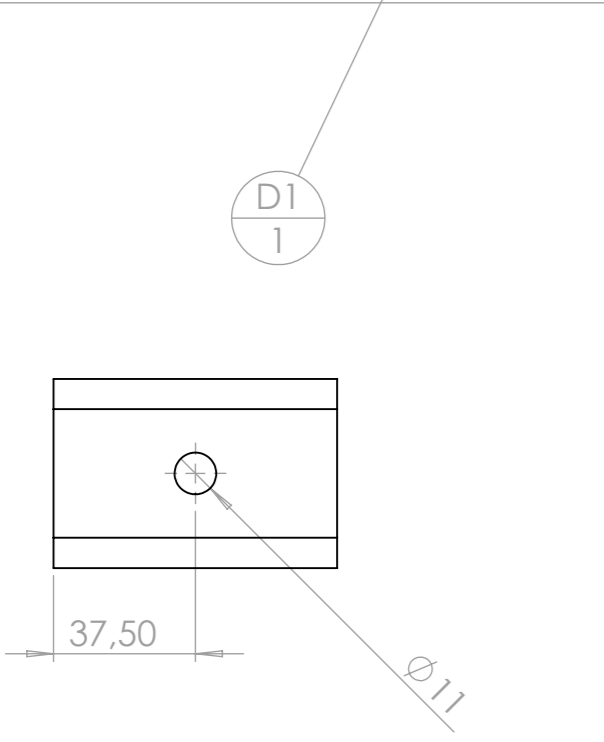
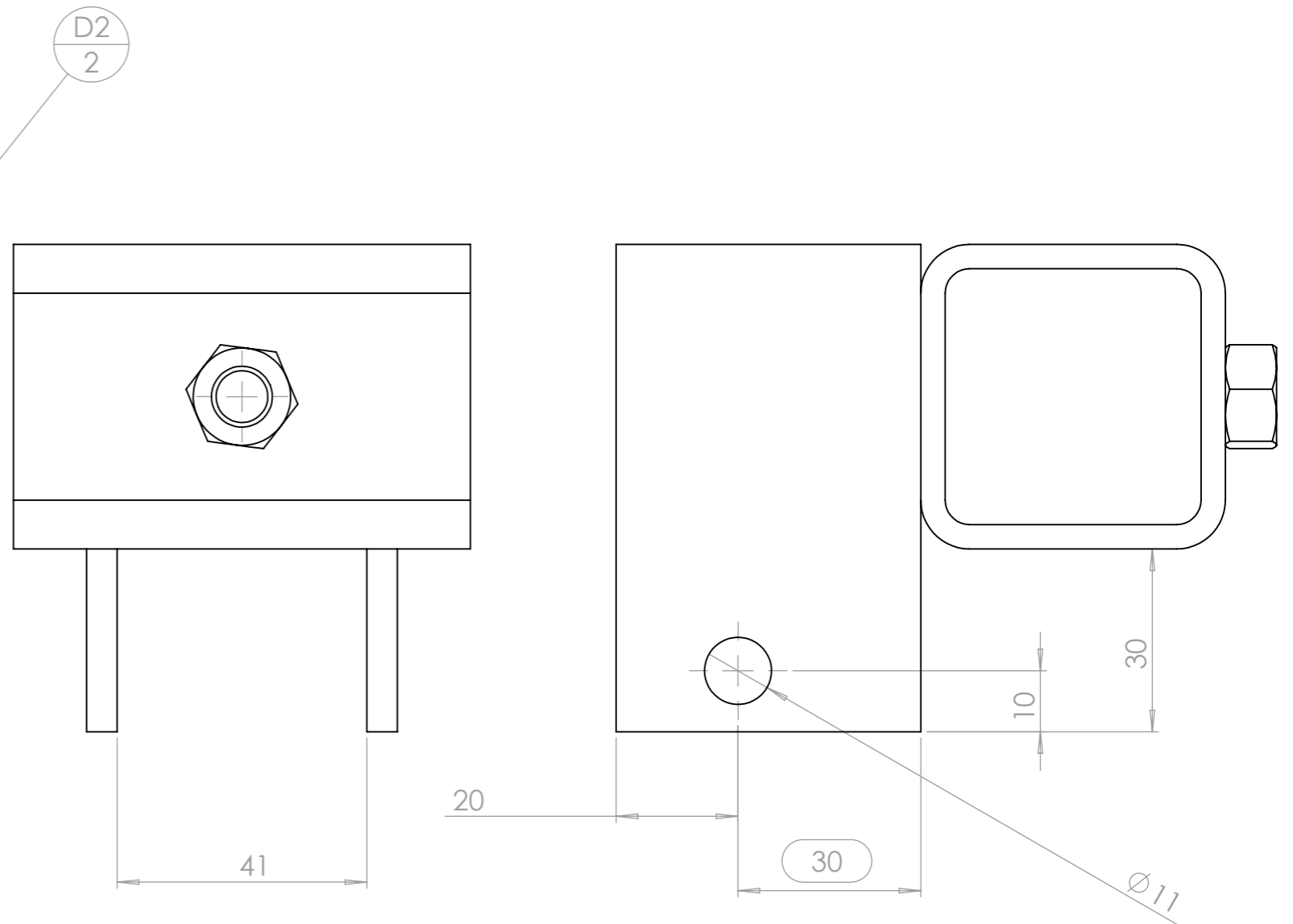
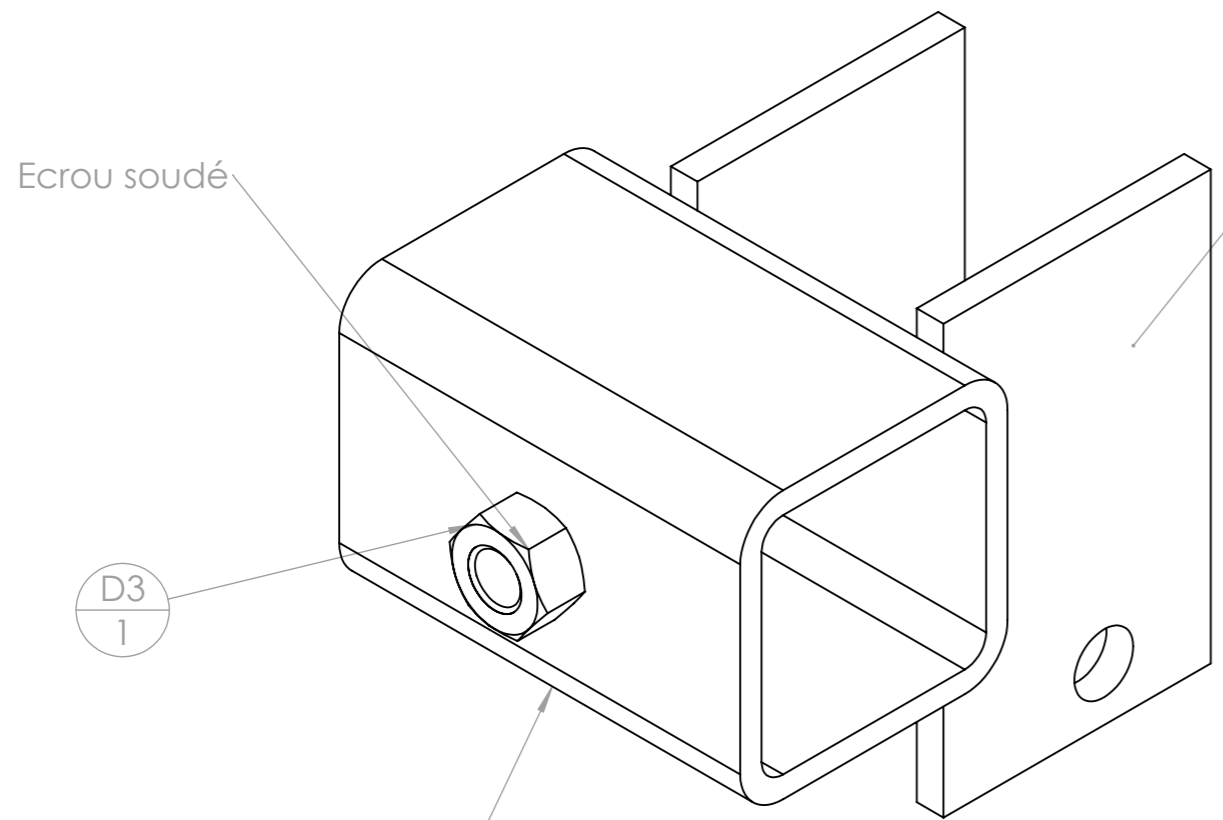

ID	Description	ANGLE1	ANGLE2	p	Longueur	Qté
D1	tube carré 50 x 4	0.00	0.00	1x Ø11 ;	75	1
D2	Fer plat 50 x 5	0.00	0.00	1x Ø11 ;	80	2
D3	Erou M10 brut					1

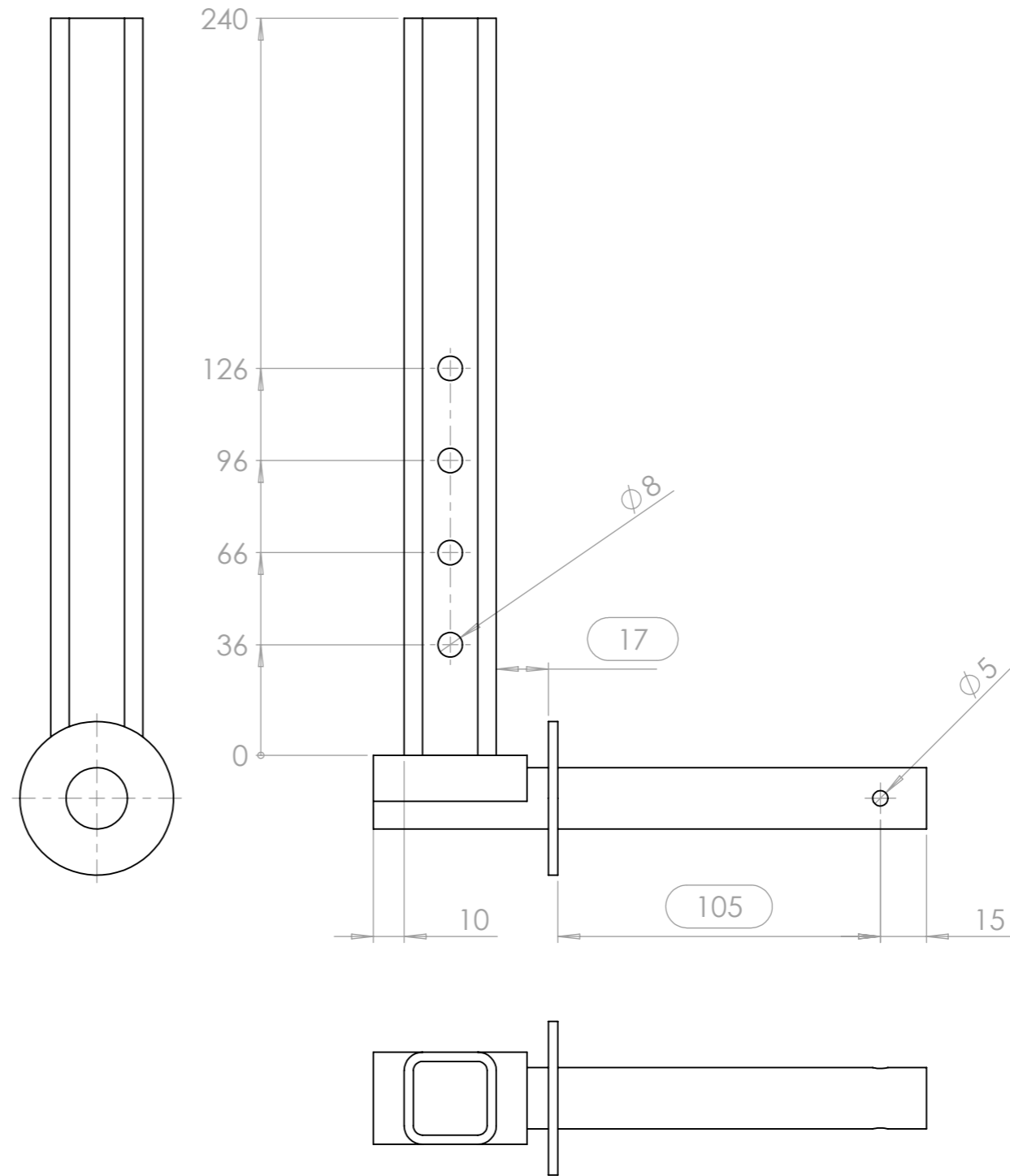
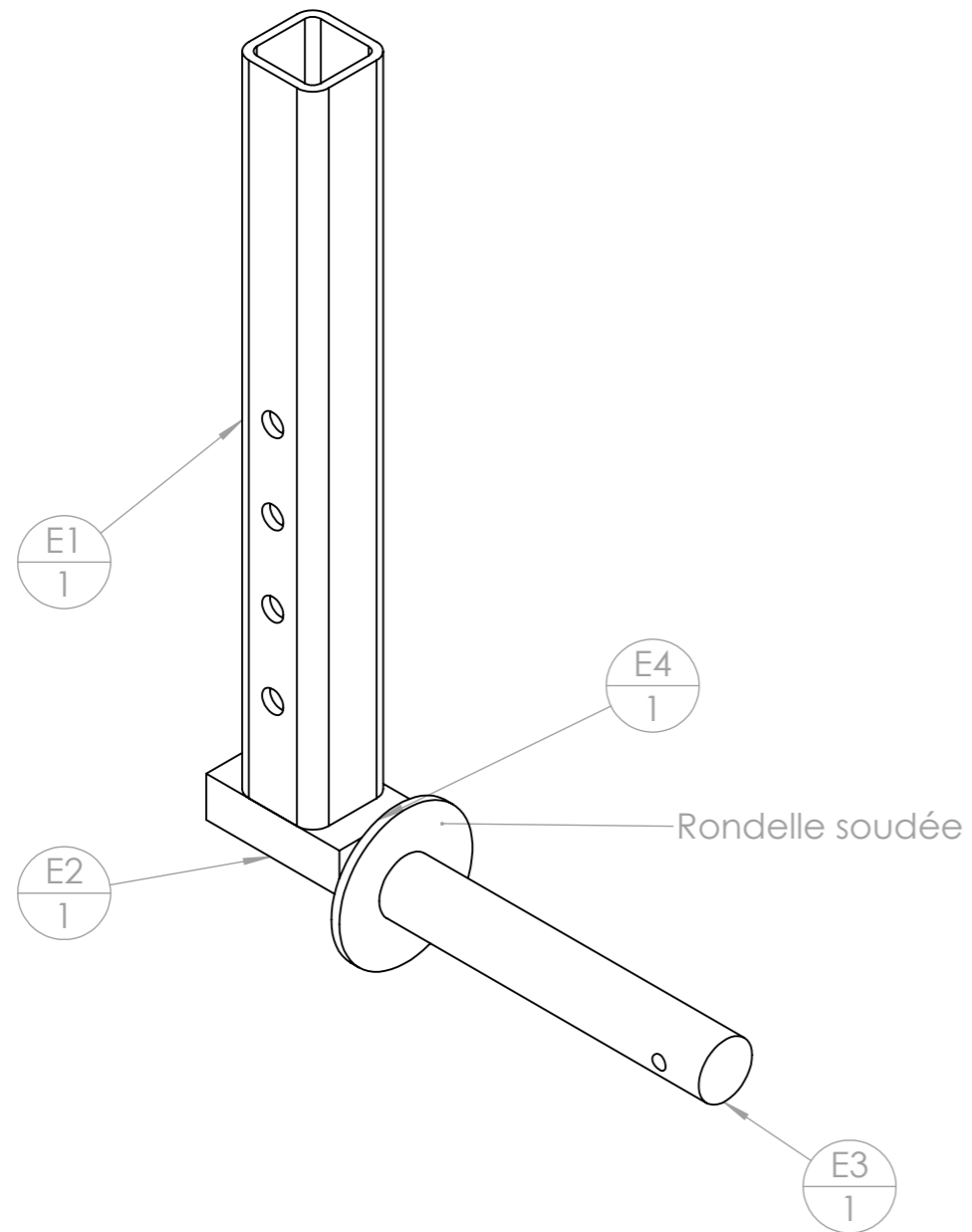

ID	Description	ANGLE1	ANGLE2	p	Longueur	Qté
E1	tube carré 30 x 3	0.00	0.00	8x Ø8 ;	240	1
E2	fer U 30 x 15 x 4	0.00	0.00		50	1
E3	étiré rond Ø20	0.00	0.00	1x Ø5 ;	180	1
E4	Rondelle Ø20 série LU			1x Ø20 ;		1

ID	Description	ANGLE1	ANGLE2	p	Longueur	Qté
F1	tube carré 40 x 3	0	0		1000	1

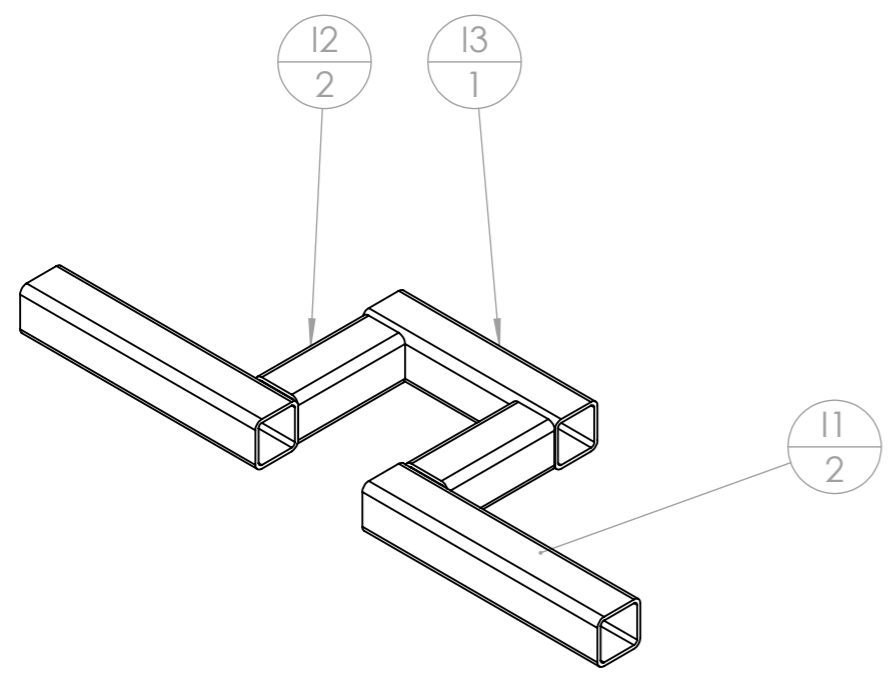
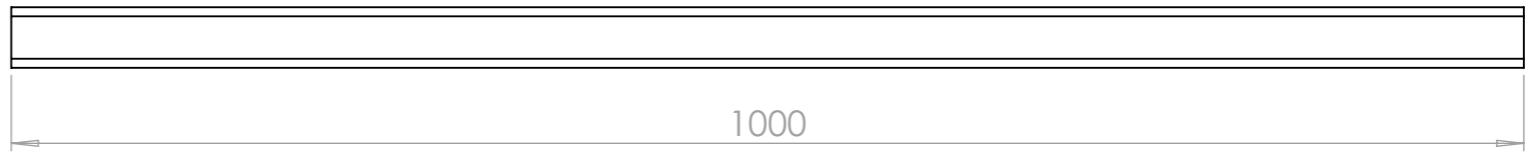
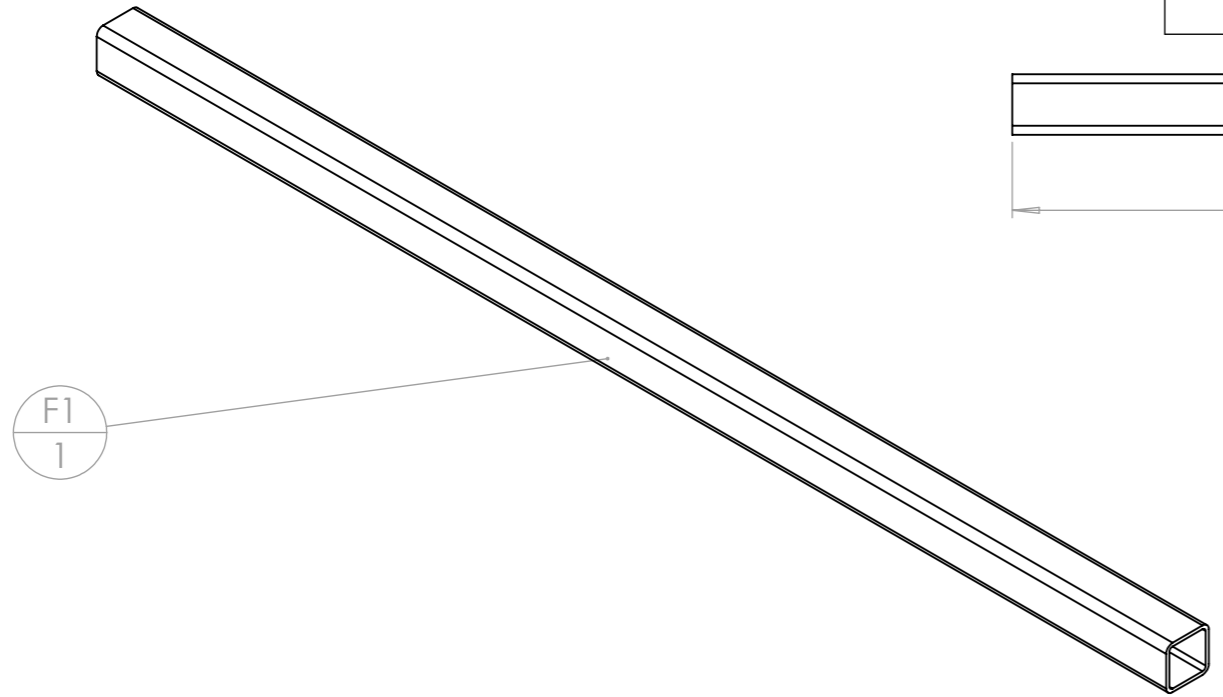

ID	Description	ANGLE1	ANGLE2	p	Longueur	Qté
I1	tube carré 40 x 3	0	0		220	2
I2	tube carré 40 x 3	0	0		100	2
I3	tube carré 40 x 3	0	0		180	1

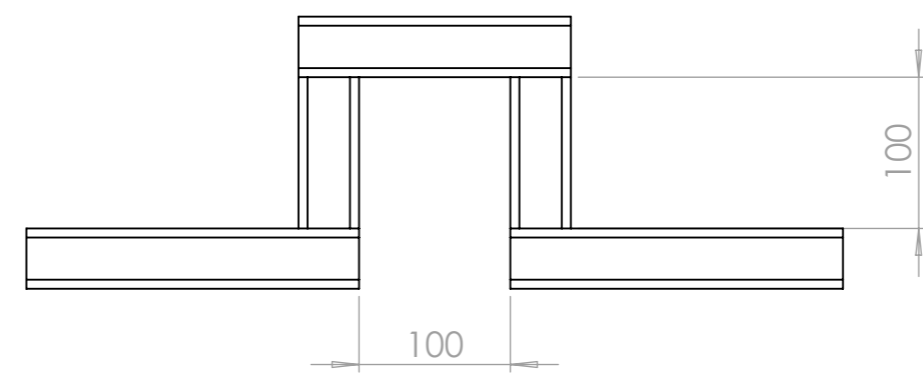

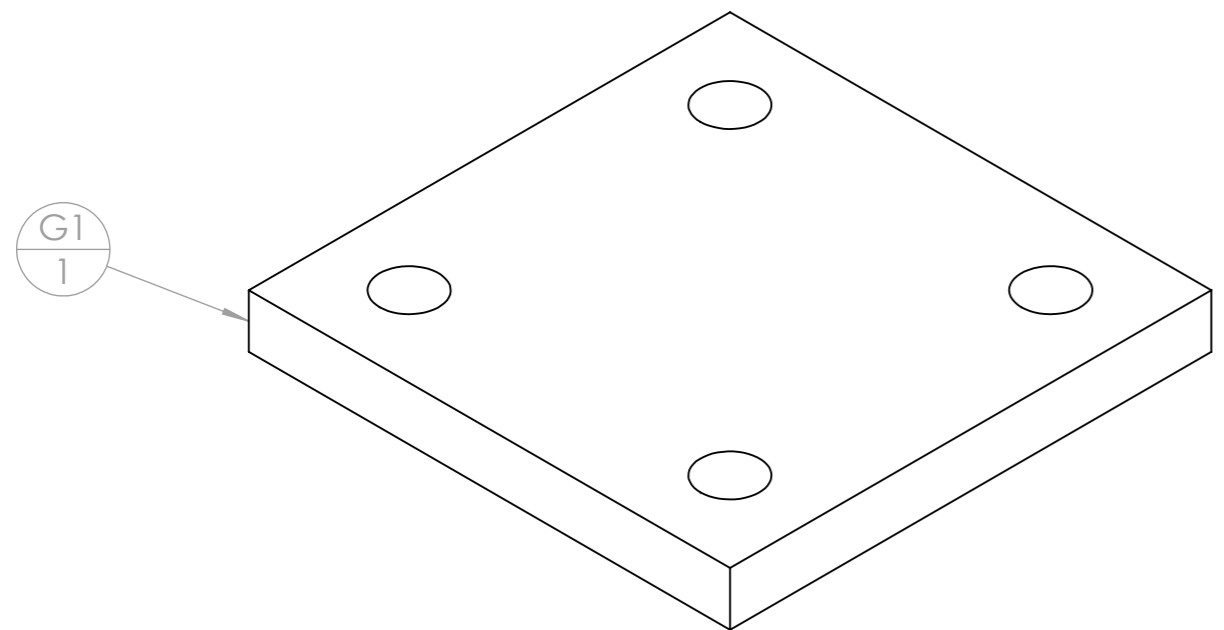
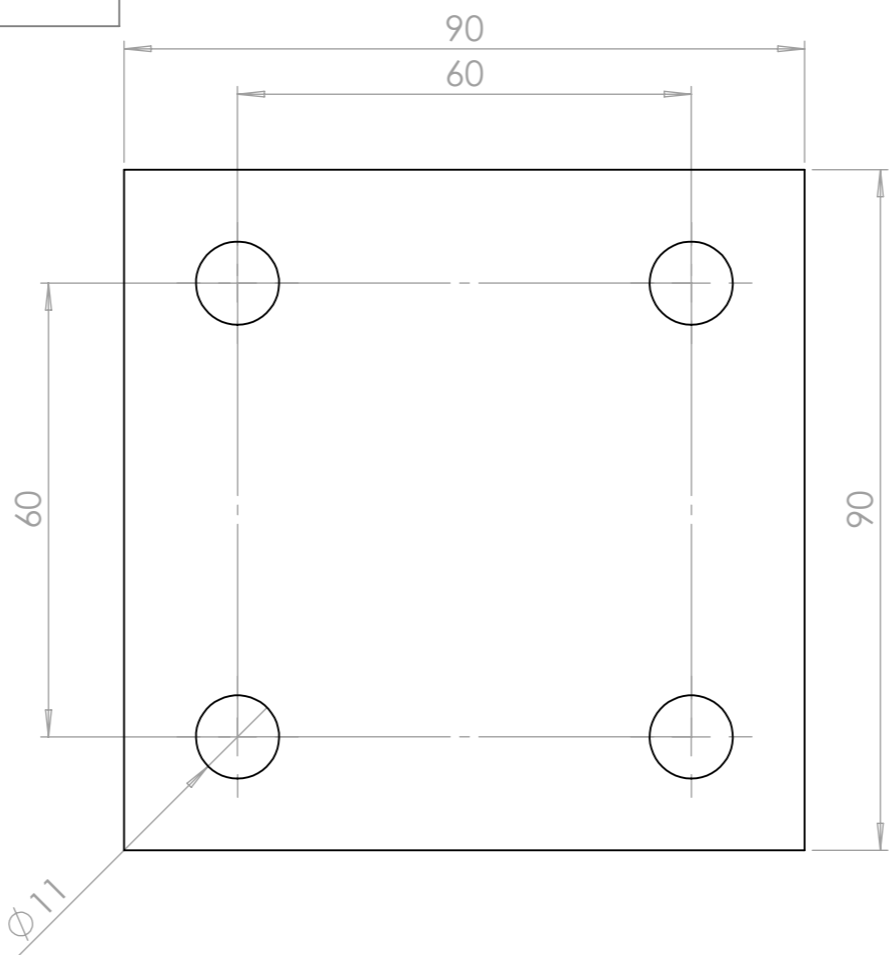

Acier S235

ID	Description	ANGLE1	ANGLE2	p	Longueur	Qté
G1	Platine relevage kassine			4x Ø11 ;		1

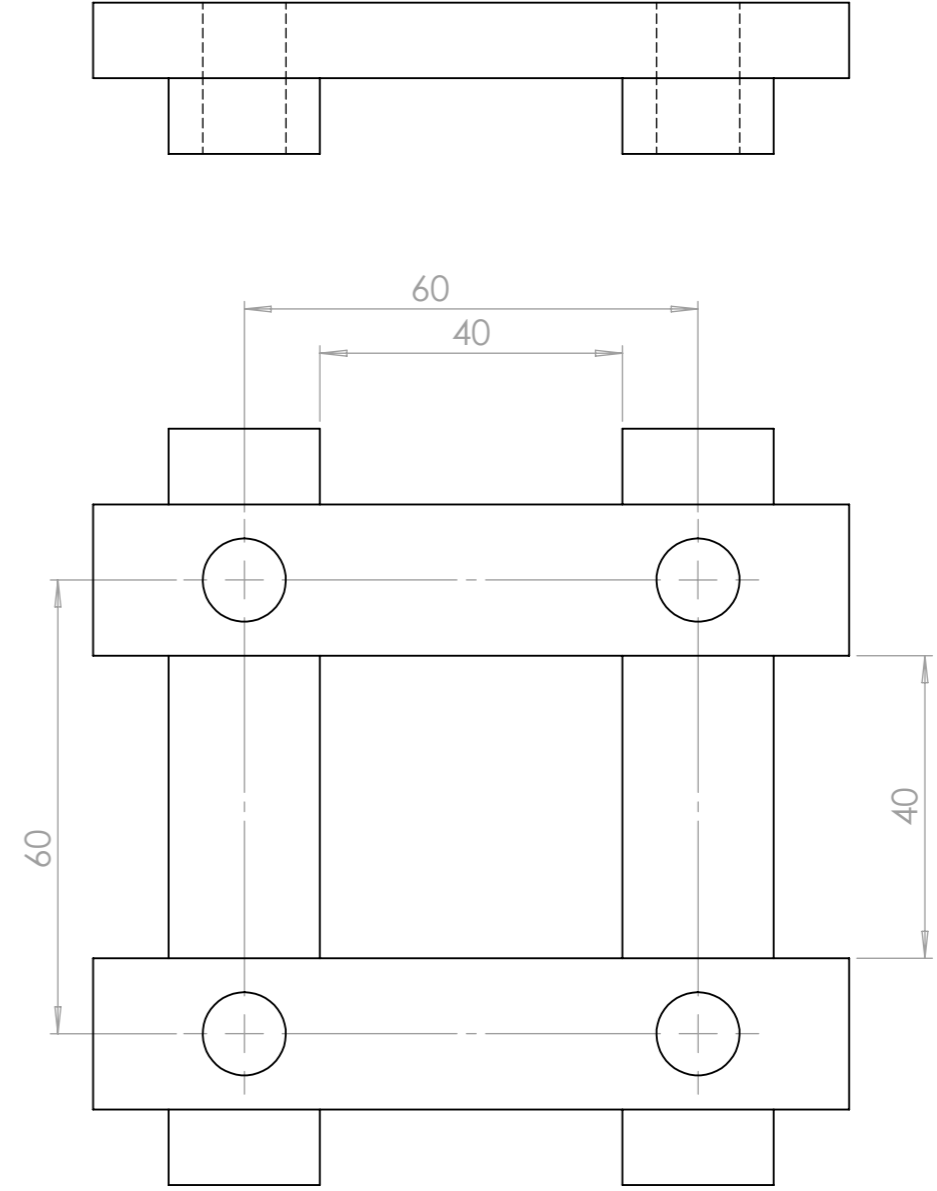
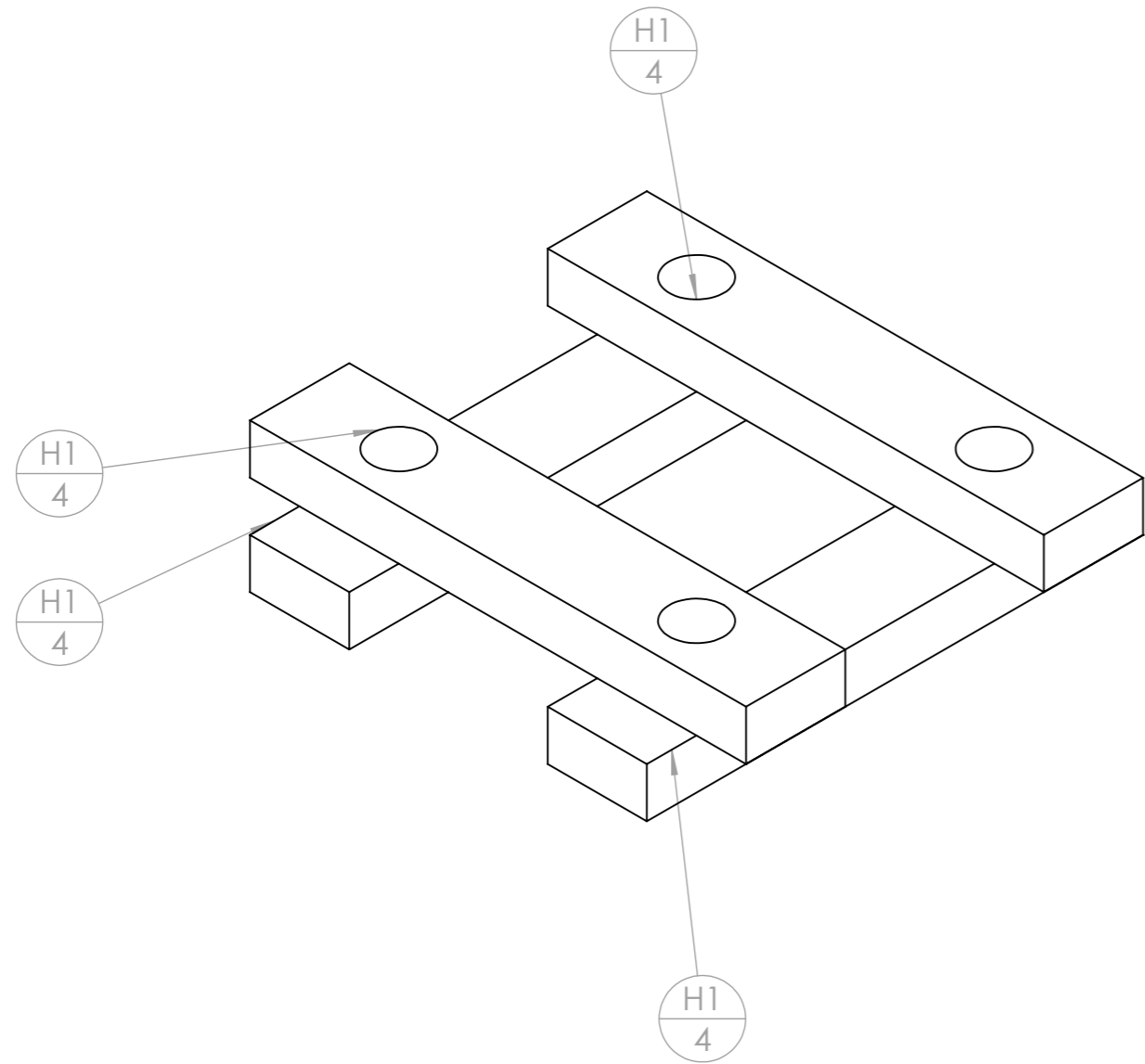

ID	Description	ANGLE1	ANGLE2	p	Longueur	Qté
H1	Fer plat 20 x 10	0	0	2x Ø11 ;	100	4

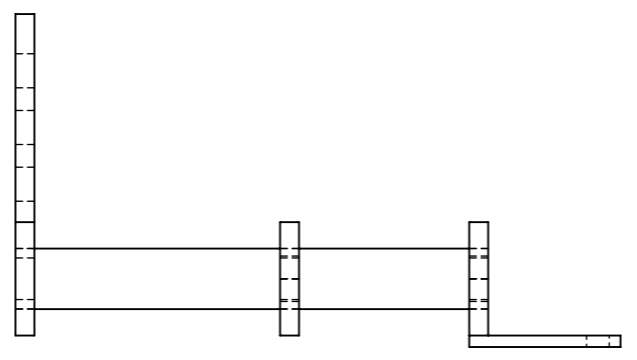
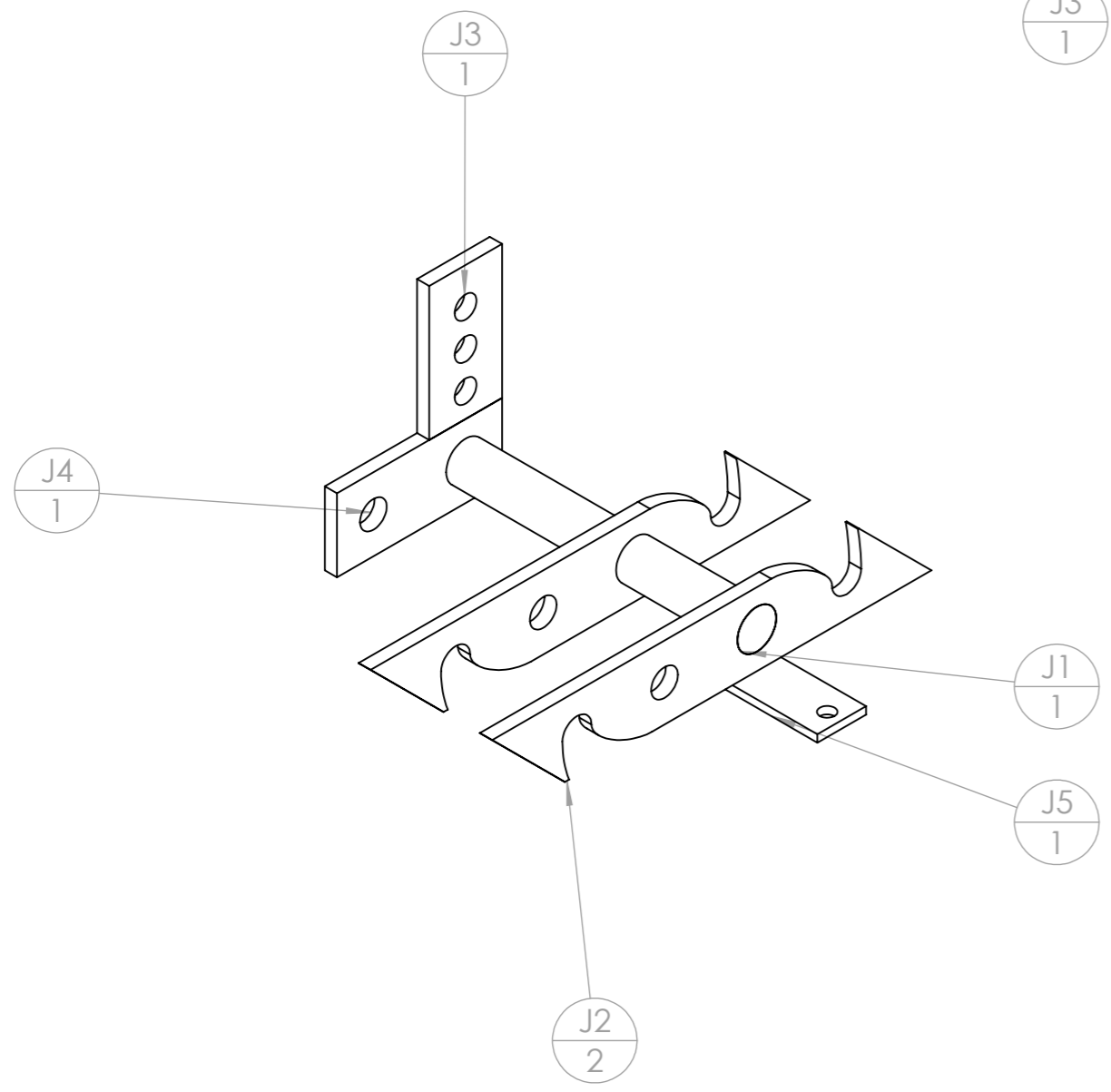
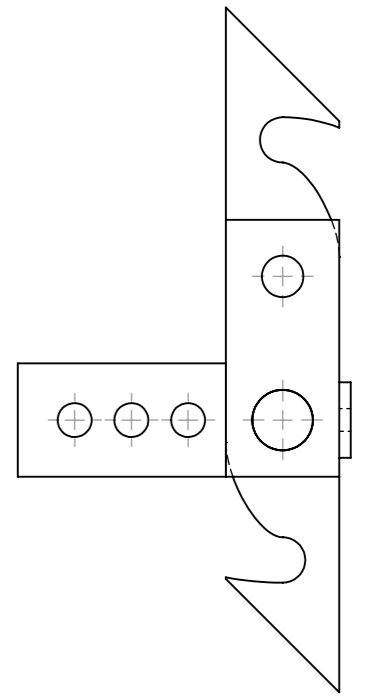
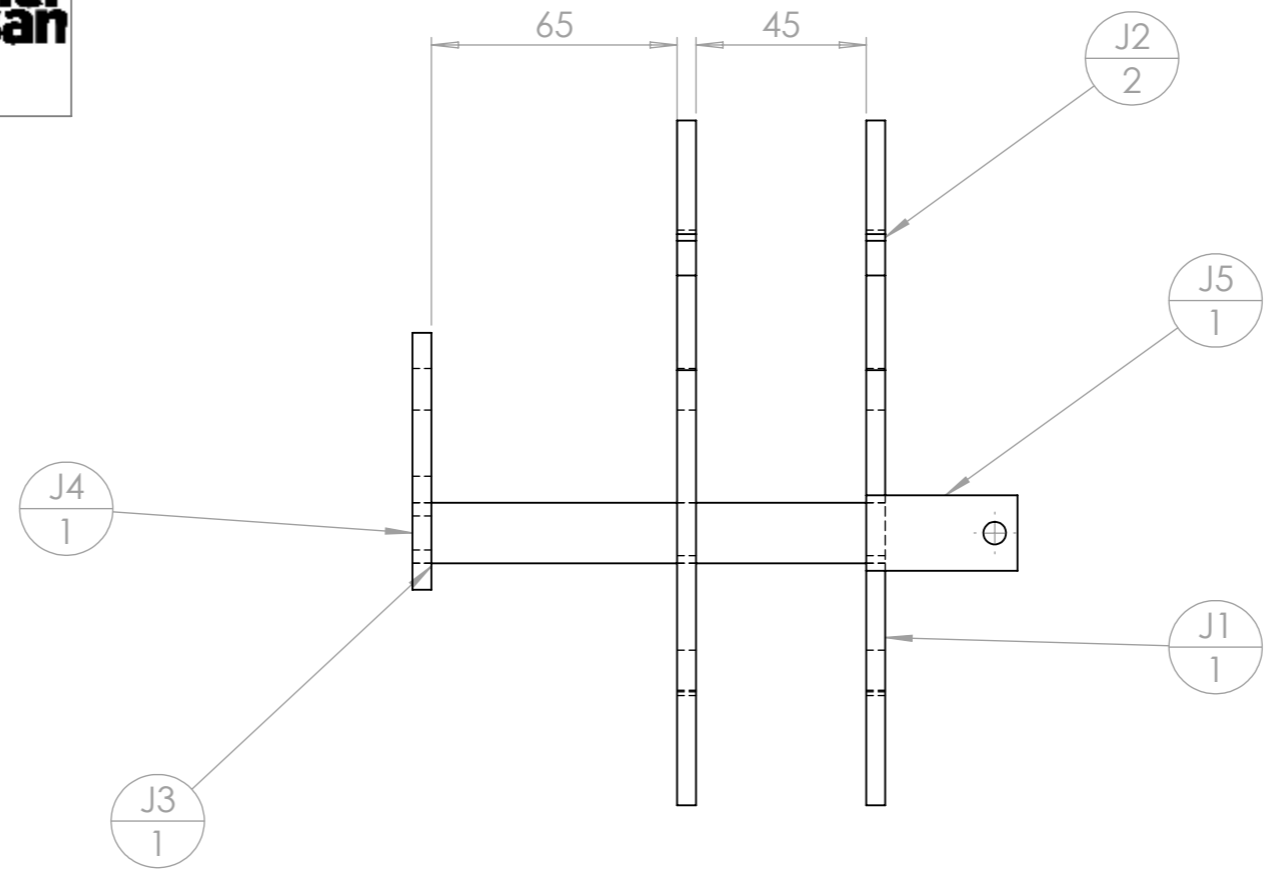

ID	Description	ANGLE1	ANGLE2	p	Longueur	Qté
J1	fer rond Ø16	0.00	0.00		125	1
J2	Fer plat 30 x 5	45.00	45.00	1x Ø16 ; 1x Ø11 ;	181	2
J3	Fer plat 30 x 5	0.00	0.00	3x Ø9 ;	55	1
J4	Fer plat 30 x 5	0.00	0.00	1x Ø11 ; 1x Ø16 ;	68	1
J5	Fer plat 20 x 3	0.00	0.00	1x Ø6 ;	40	1

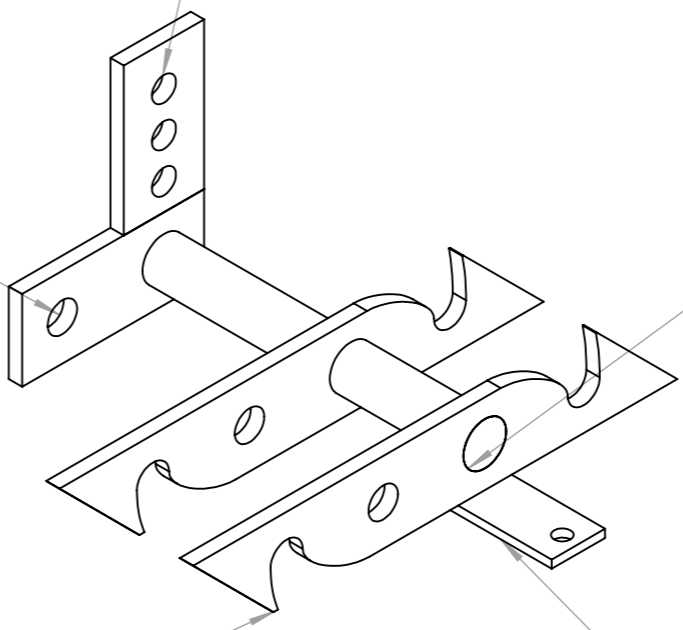
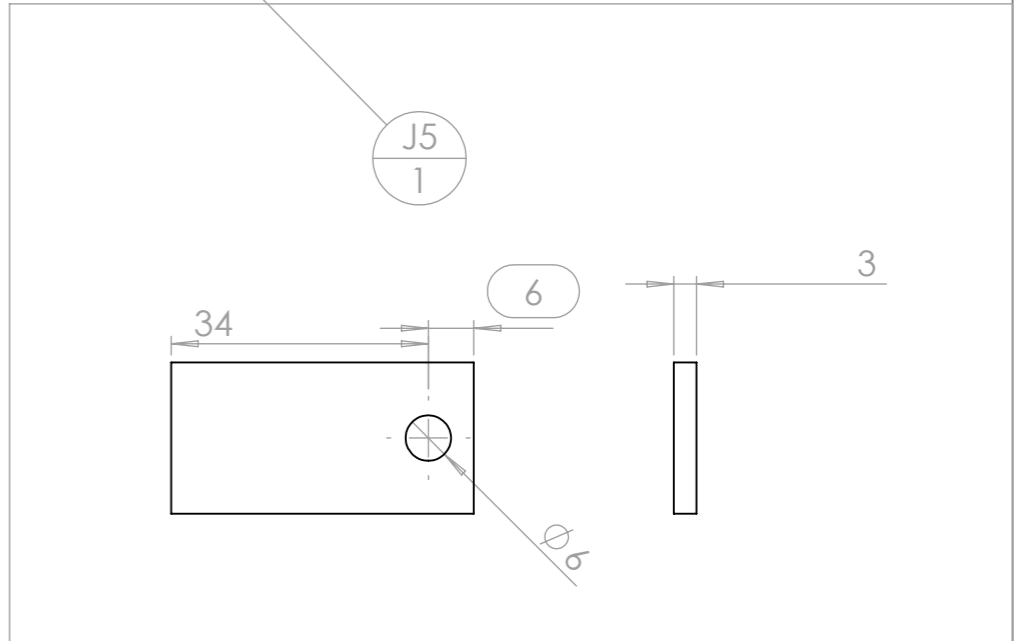
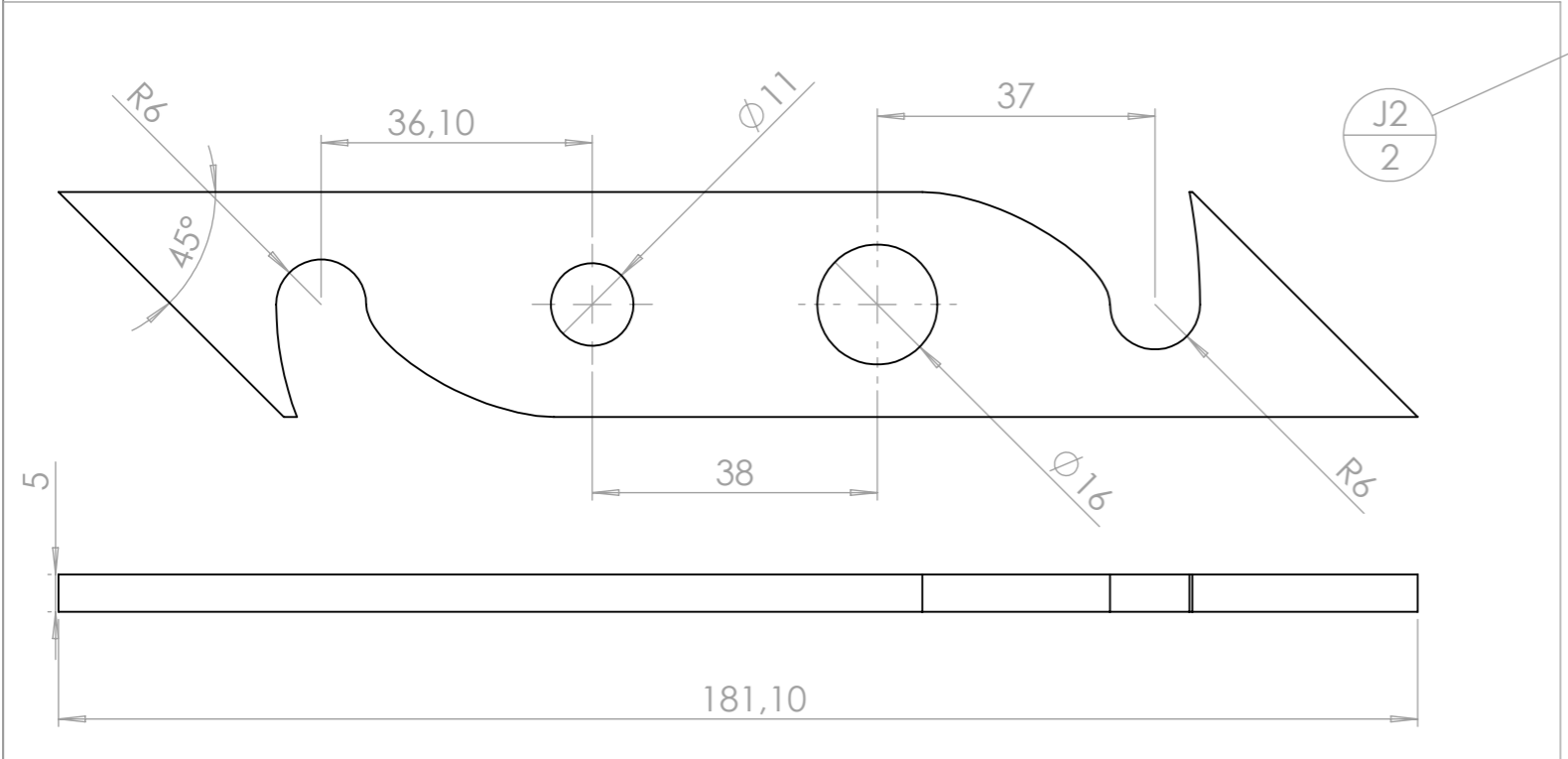
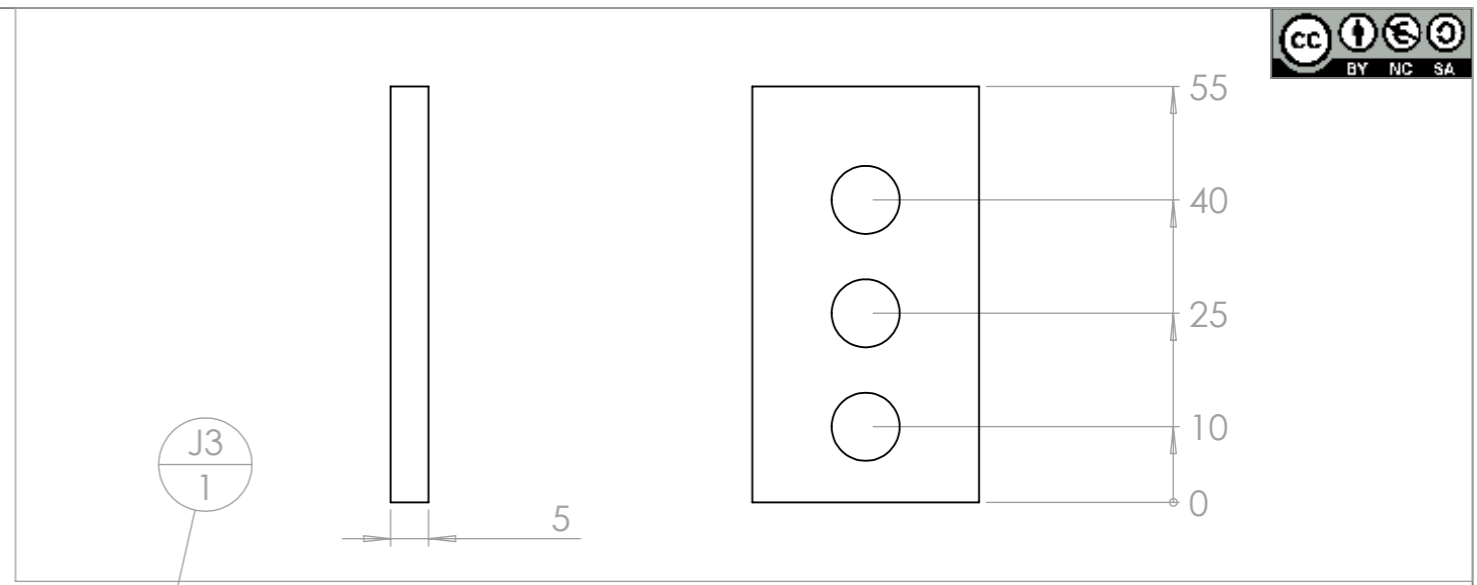
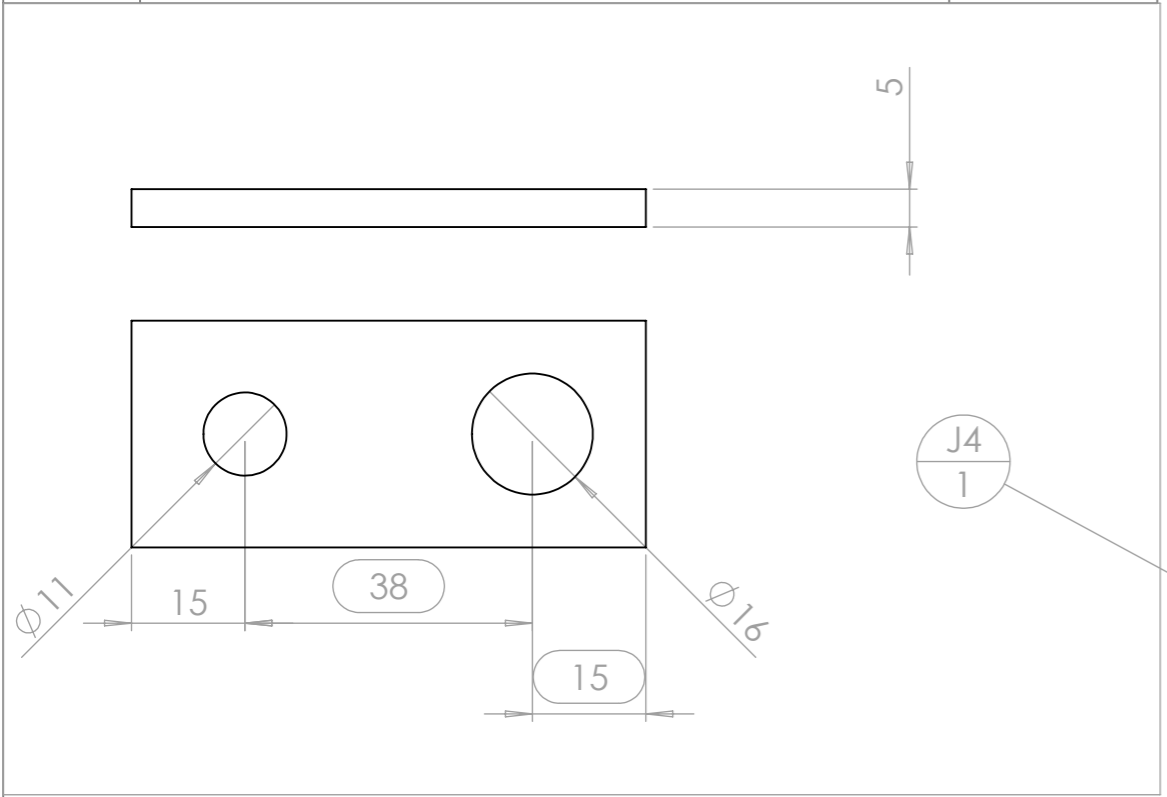

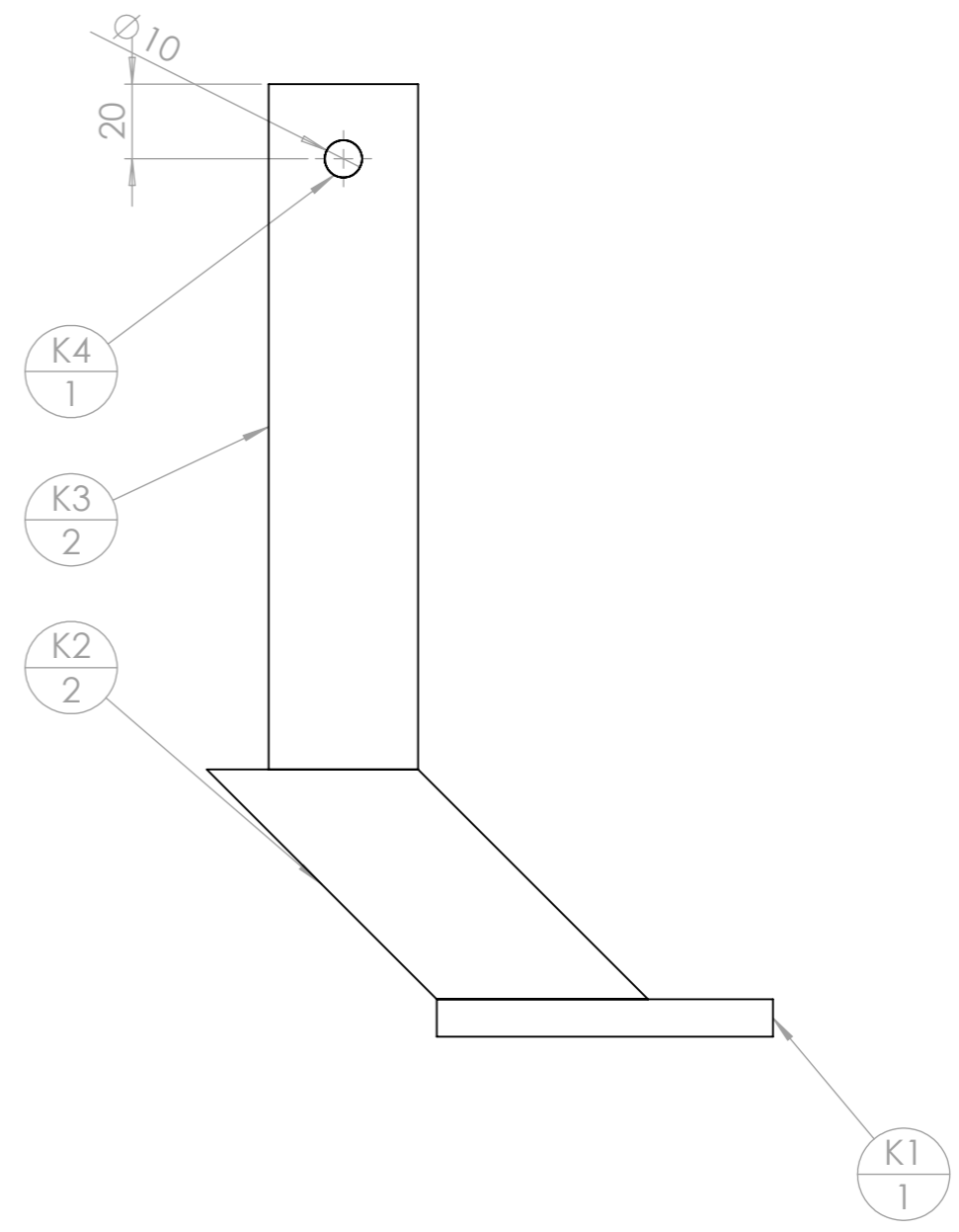
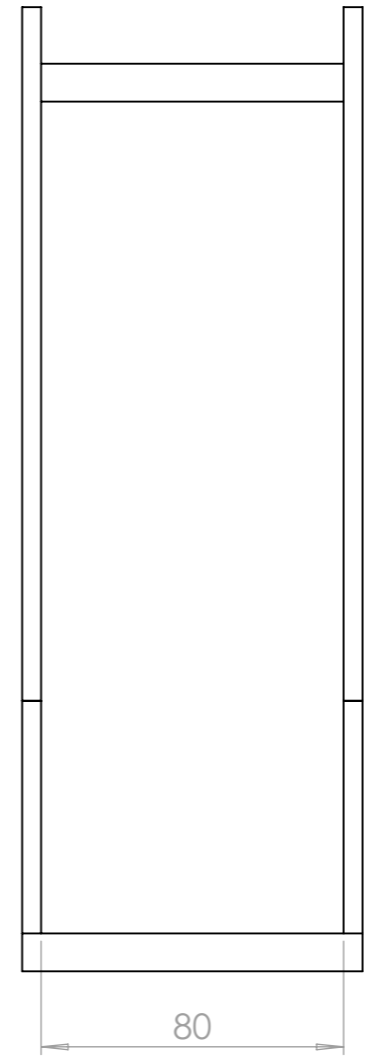
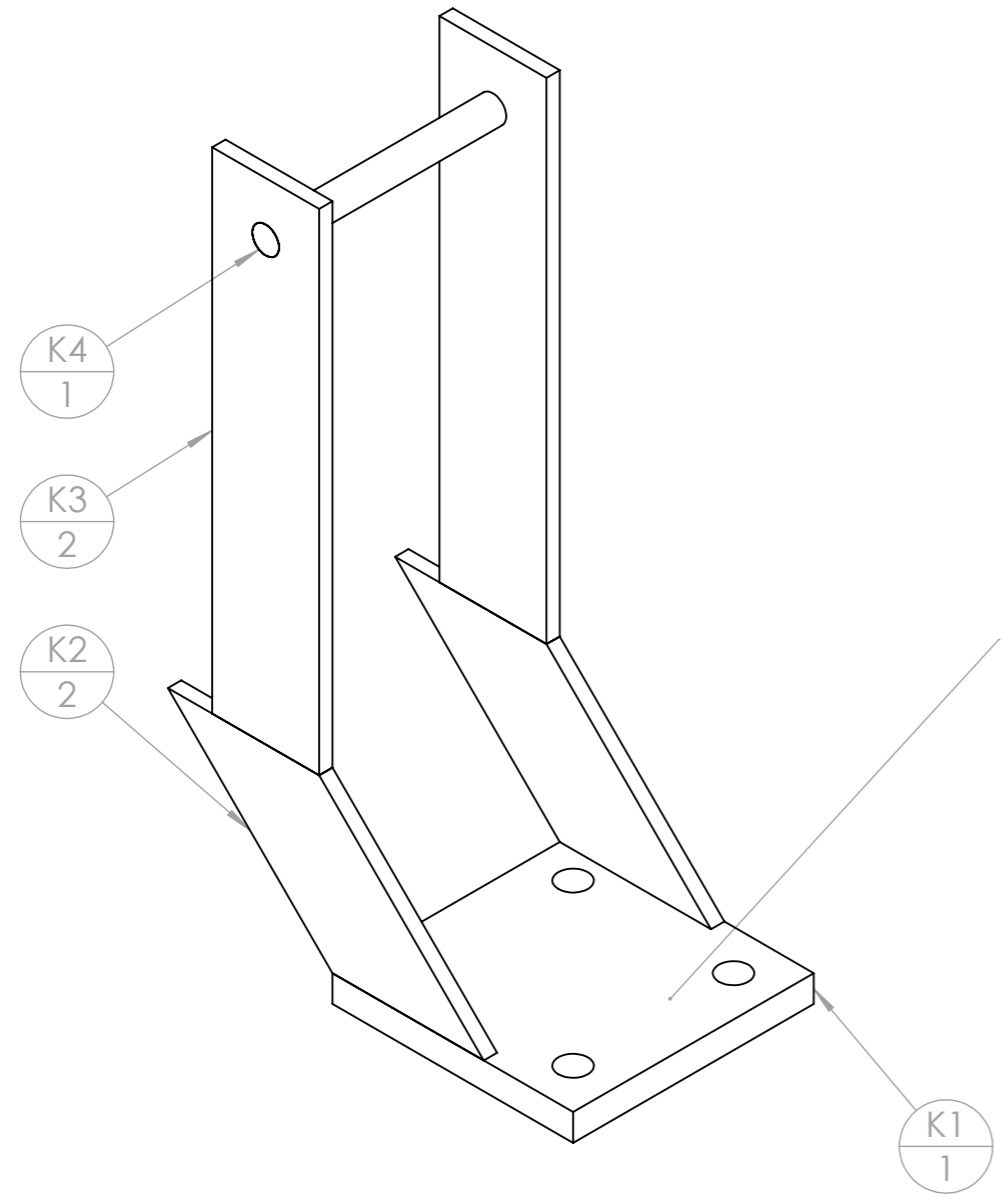

K1 similaire à G1

ID	Description	ANGLE1	ANGLE2	p	Longueur	Qté
K1	Platine relevage kassine			4x Ø11 ;		1
K2	fer plat 40 x 5	45	45		127	2
K3	fer plat 40 x 5	0	0	1x Ø10 ;	183	2
K4	fer rond Ø10	0	0		90	1

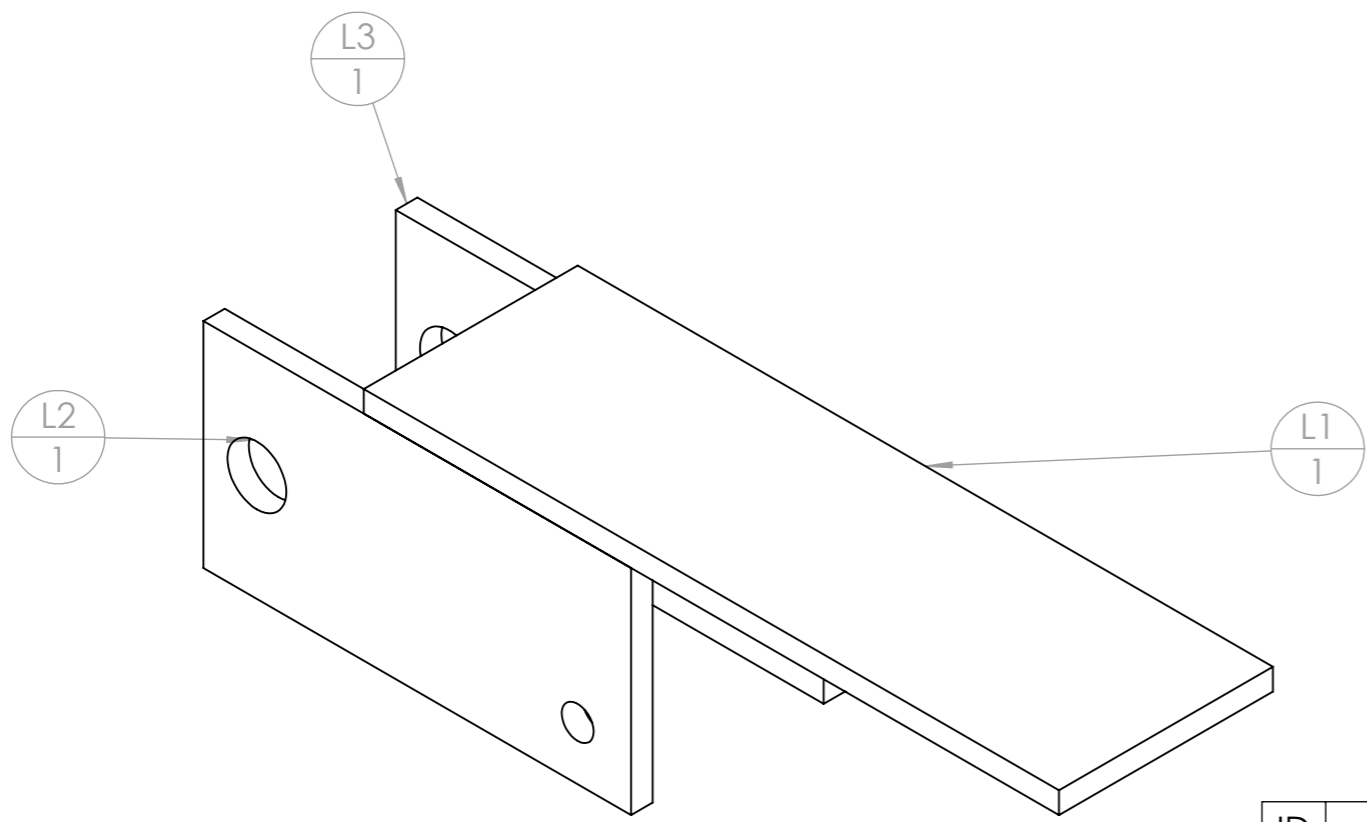
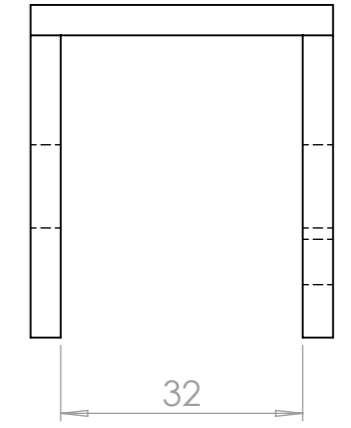
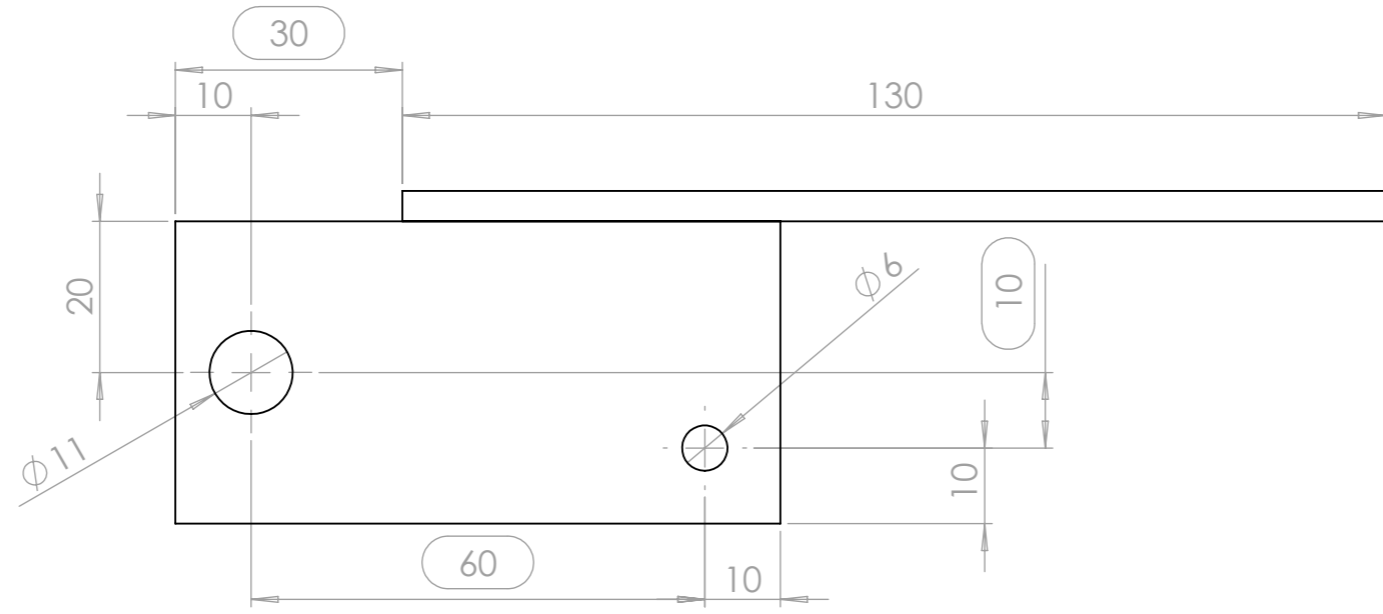

Perçage Ø6 sur L2 uniquement

ID	Description	ANGLE1	ANGLE2	p	Longueur	Qté
L1	fer plat 40 x 4	0	0		130	1
L2	fer plat 40 x 4	0	0	1x Ø11 ; 1x Ø6 ;	80	1
L3	fer plat 40 x 4	0	0	1x Ø11 ;	80	1

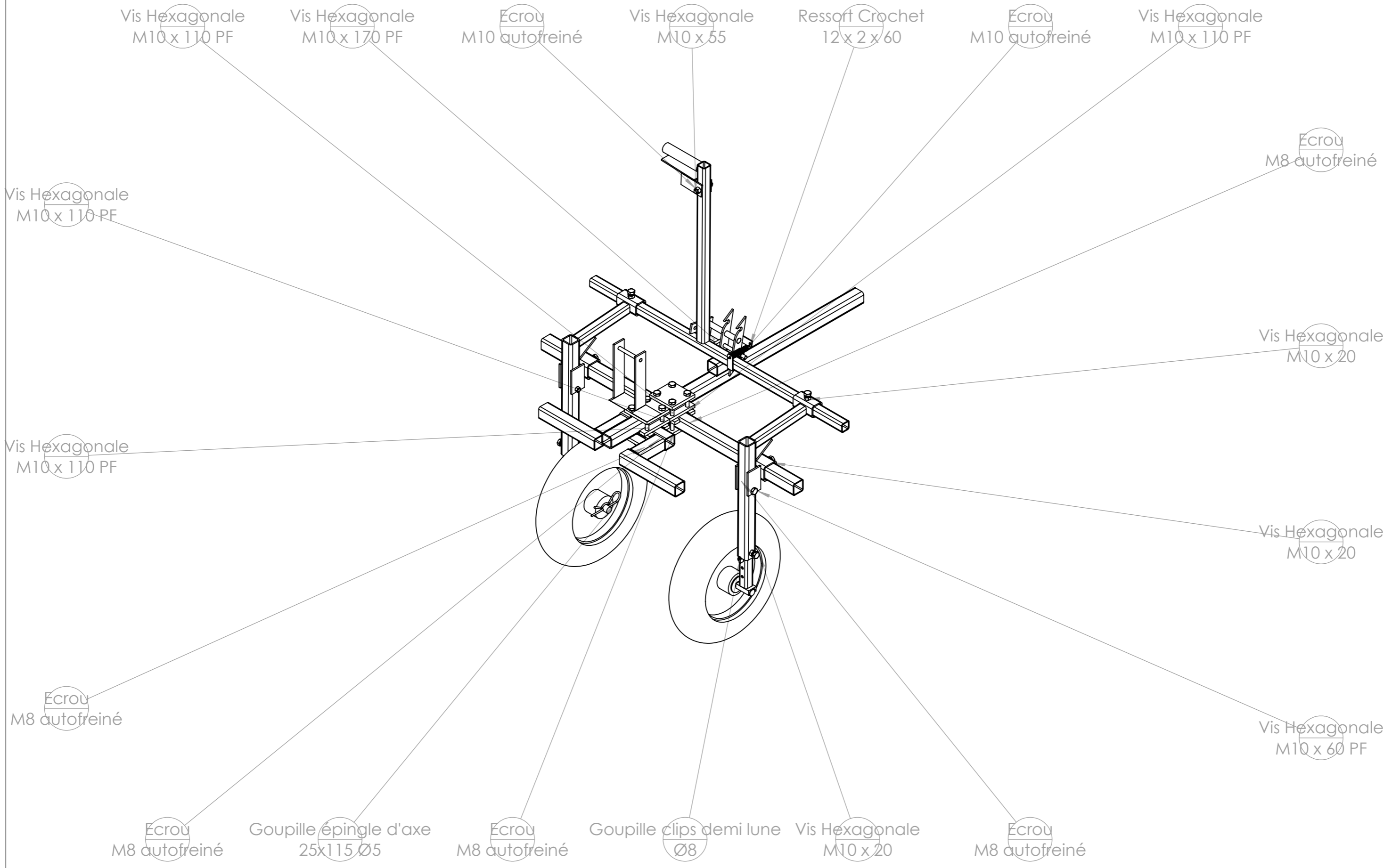

Outil	Relevage Kassine				
Date	04/12/2020	Version	0.1	page n° 18 / 19	
Pièce	Fournitures globales			Qté	

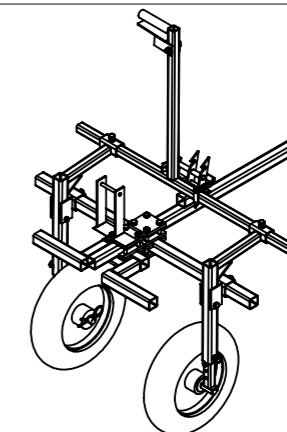

repère	Désignation	ANGLE1	ANGLE2	p	LONGUEUR	Quantité
A	Age					1
A1	tube carré 40 x 3	0	0	2x Ø12 ;	80	1
A2	Fer rond Ø12	0	0		100	1
B	Levier relevage					1
B1	tube carré 30 x 3	0	0		1000	1
B2	tube carré 30 x 3	0	0	2x Ø11 ;	600	1
B3	tube rond 30 x 2	0	0	1x Ø26 ;	135	1
B4	Fer plat 20 x 10	0	0	1x Ø11 ;	35	3
B5	Fer plat 20 x 3	0	0	1x Ø6 ;	50	1
C	support roue et levier droite					1
C1	tube carré 40 x 4	0.00	0.00	1x Ø11 ;	75	1
C2	tube carré 30 x 3	5.00	5.00		203	1
C3	tube carré 40 x 4	0.00	0.00	3x Ø11 ;	390	1
C4	Ecrou M10 brut			1x Ø8,5 ; 2x Ø10 ;		2
C5	Fer plat 30 x 6	0.00	0.00		75	1
D	Pivot relevage					2
D1	tube carré 50 x 4	0.00	0.00	1x Ø11 ;	75	1
D3	Ecrou M10 brut					1
D2	Fer plat 50 x 5	0.00	0.00	1x Ø11 ;	80	2
E	Montant roue					2
E1	tube carré 30 x 3	0.00	0.00	8x Ø8 ;	240	1
E2	fer U 30 x 15 x 4	0.00	0.00		50	1
E3	étiré rond Ø20	0.00	0.00	1x Ø5 ;	180	1
E4	Rondelle Ø20 série LU			1x Ø20 ;		1
J	blocage pivotant					1
J1	fer rond Ø16	0.00	0.00		125	1
J2	Fer plat 30 x 5	45.00	45.00	1x Ø16 ; 1x Ø11 ;	181	2
J3	Fer plat 30 x 5	0.00	0.00	3x Ø9 ;	55	1
J4	Fer plat 30 x 5	0.00	0.00	1x Ø11 ; 1x Ø16 ;	68	1
J5	Fer plat 20 x 3	0.00	0.00	1x Ø6 ;	40	1
L	gâchette					1
L1	fer plat 40 x 4	0	0		130	1
L2	fer plat 40 x 4	0	0	1x Ø11 ; 1x Ø6 ;	80	1
L3	fer plat 40 x 4	0	0	1x Ø11 ;	80	1

repère	Désignation	ANGLE1	ANGLE2	p	LONGUEUR	Quantité
Roue	Roue gonflable Ø399 ; 1104 ref FR1400820100					2
F	Poutre relevage					1
F1	tube carré 40 x 3	0	0		1000	1
I	Poutre arrière					1
I1	tube carré 40 x 3	0	0		220	2
I2	tube carré 40 x 3	0	0		100	2
I3	tube carré 40 x 3	0	0		180	1
H	Croisillon interne					2
H1	Fer plat 20 x 10	0	0	2x Ø11 ;	100	4
G	bride externe					3
G1	Platine relevage kassine			4x Ø11 ;		1
K	bride externe					1
K1	Platine relevage kassine			4x Ø11 ;		1
K2	fer plat 40 x 5	45	45		127	2
K3	fer plat 40 x 5	0	0	1x Ø10 ;	183	2
K4	fer rond Ø10	0	0		90	1
C	support roue et levier gauche					1
C1	tube carré 40 x 4	0.00	0.00	1x Ø11 ;	75	1
C2	tube carré 30 x 3	5.00	5.00		203	1
C3	tube carré 40 x 4	0.00	0.00	3x Ø11 ;	390	1
C4	Ecrou M10 brut			1x Ø8,5 ; 2x Ø10 ;		2
C5	Fer plat 30 x 6	0.00	0.00		75	1
Goupille clips demi lune	goupille clips demi lune Ø8					2
Vis Hexagonale	Vis hexagonale M10 x 60 PF					2
Ecrou	Ecrou M8 autofreiné					10
Vis Hexagonale	Vis hexagonale M10 x 20					6
Vis Hexagonale	Vis hexagonale M10 x 110 PF					8
Vis Hexagonale	Vis hexagonale M10 x 170 PF					1
Ecrou	Ecrou M10 autofreiné					2
Ressort	ressort traction 12 x 2 x 60				60	1
Goupille épingle d'axe	Goupille épingle d'axe 25x115 Ø5					2
Vis Hexagonale	vis hexagonale M10 x 55					1

Outil	Relevage Kassine				
Date	04/12/2020	Version	0.1	page n° 19 / 19	
Pièce	Contributions		Qté	1	



Les travaux pour réaliser la présente mise à jour ont bénéficié d'une contribution des collectivités publiques :



Cette action est cofinancée par le Fonds européen agricole pour le développement rural : l'Europe investit dans les zones rurales.



Cette mise à jour, comme les précédentes, a bénéficié de la contribution bénévole et décisive des nombreux(ses) paysan(ne)s, membres formels ou informels du collectif L'Atelier Paysan.