

Outil	porte tout				
Date	10/03/2019	Version	2.0	page n° 1 / 11	
Pièce	Préambule		Qté	1	

# Avant de commencer



La présente version est le résultat des évolutions par l'usage, d'expérimentations paysannes quotidiennes, des ajustements pratiques issus des retours des participants aux nombreuses formations et journées de terrain collectives.

L'autoconstruction de votre outil à l'aide de ce tutoriel n'est que le début de votre aventure. Si cette machine est pertinente en l'état pour de nombreux contextes, vous allez devoir l'adapter, la régler, la modifier pour l'ajuster à votre projet agronomique, vos itinéraires techniques, vos conditions pédo-climatiques. Vous allez donc faire vivre cette machine.

Merci de nous faire parvenir vos retours, vos découvertes, vos réussites. Vos expériences individuelles, vos tâtonnements de terrain viendront enrichir le pot commun paysan, sous même licence libre que les présents plans.

<http://www.latelierpaysan.org/>



<http://forum.latelierpaysan.org>

Outil	porte tout		Ech 1:20	A3	
Date	10/03/2019	Version 2.0	page n° 2 / 11		
Pièce	présentation		Qté	1	

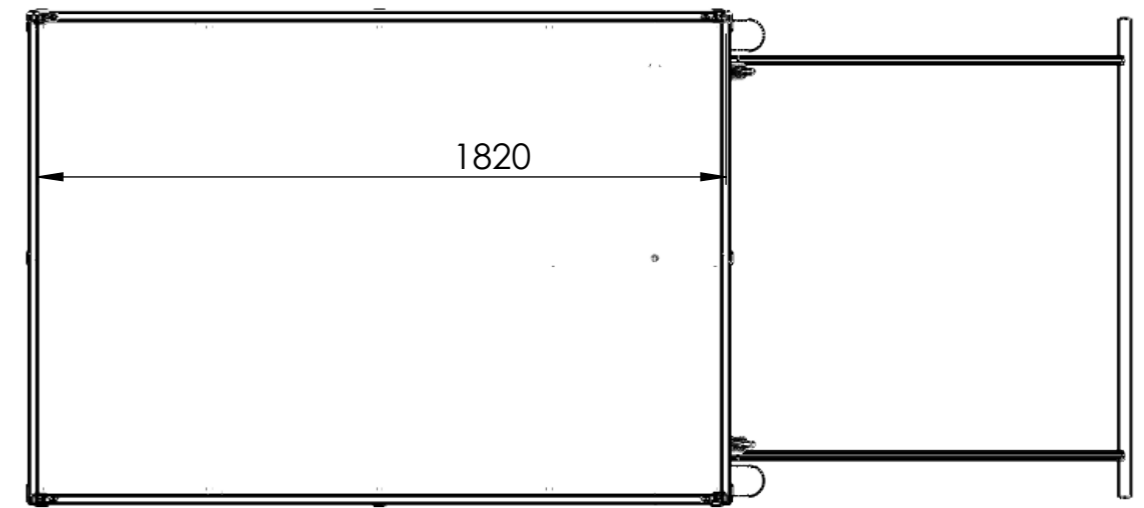
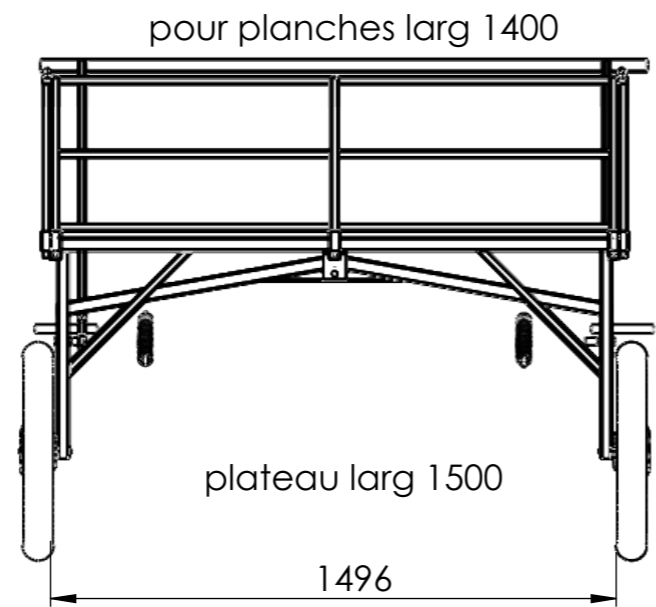
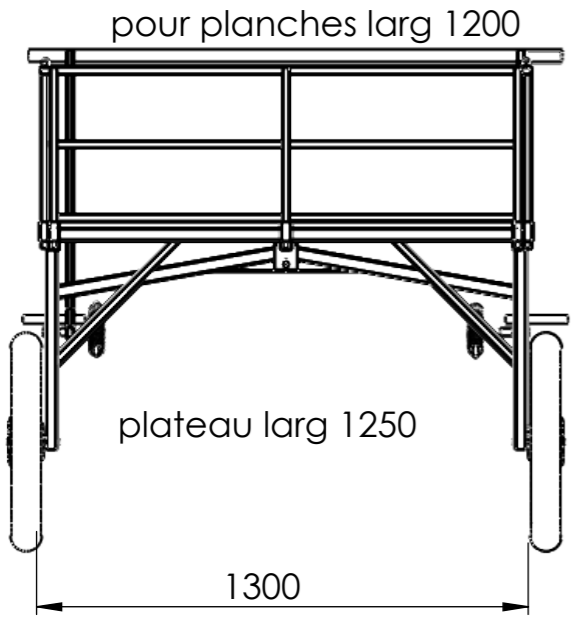
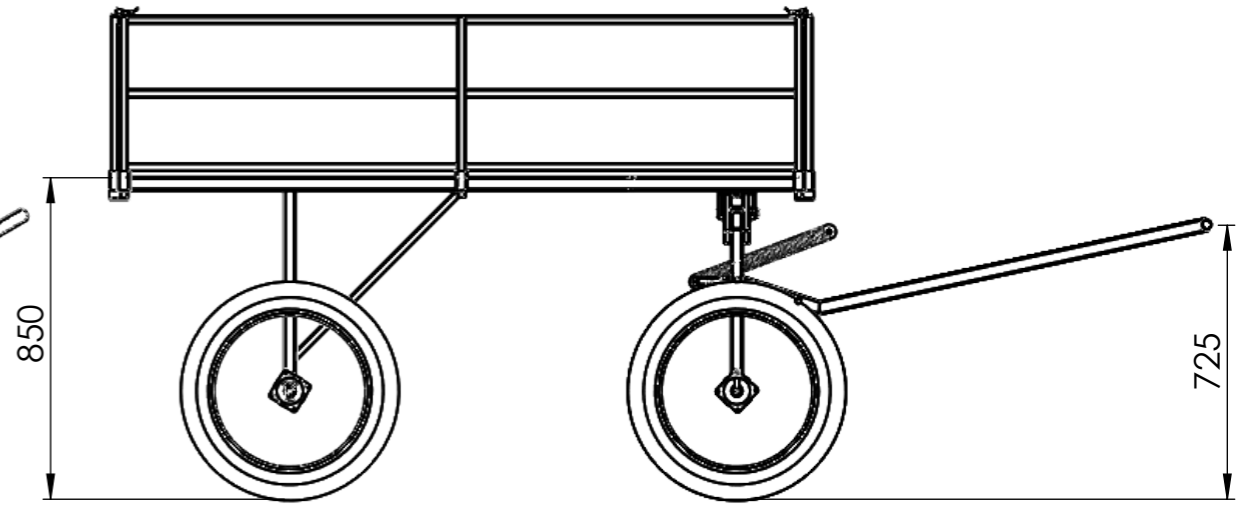
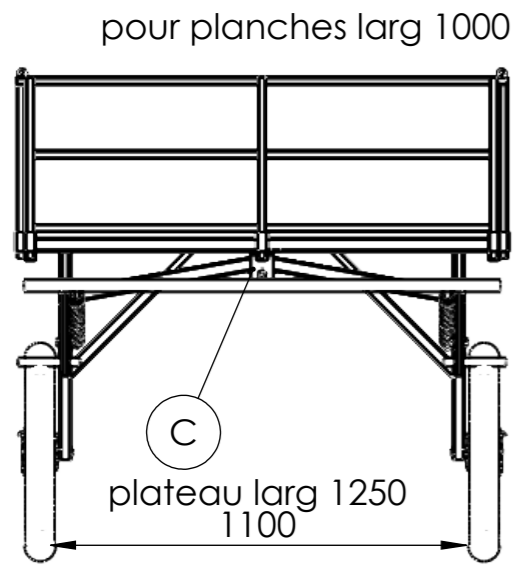
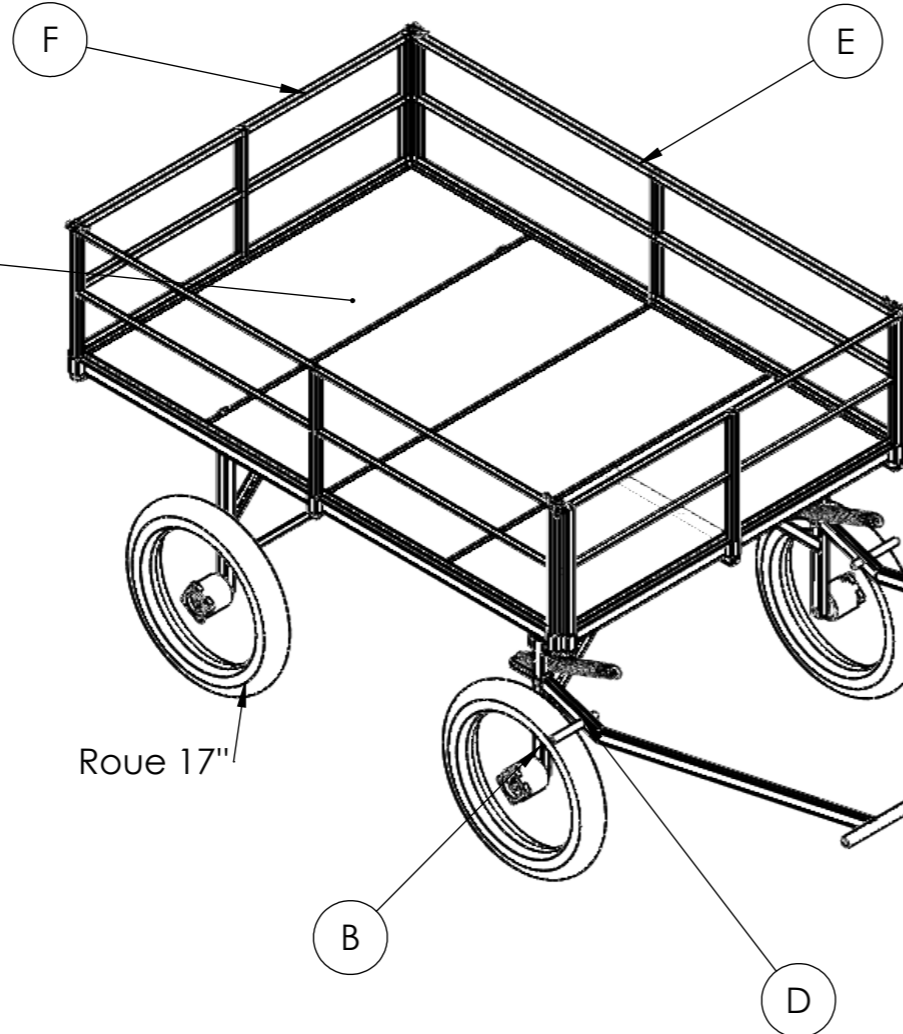

Outil	porte tout		Ech 1:15	A3	<b>L'atelier paysan</b>
Date	10/03/2019	Version 2.0	page n° 3 / 11		
Pièce	B-D larg1000		Qté	1	

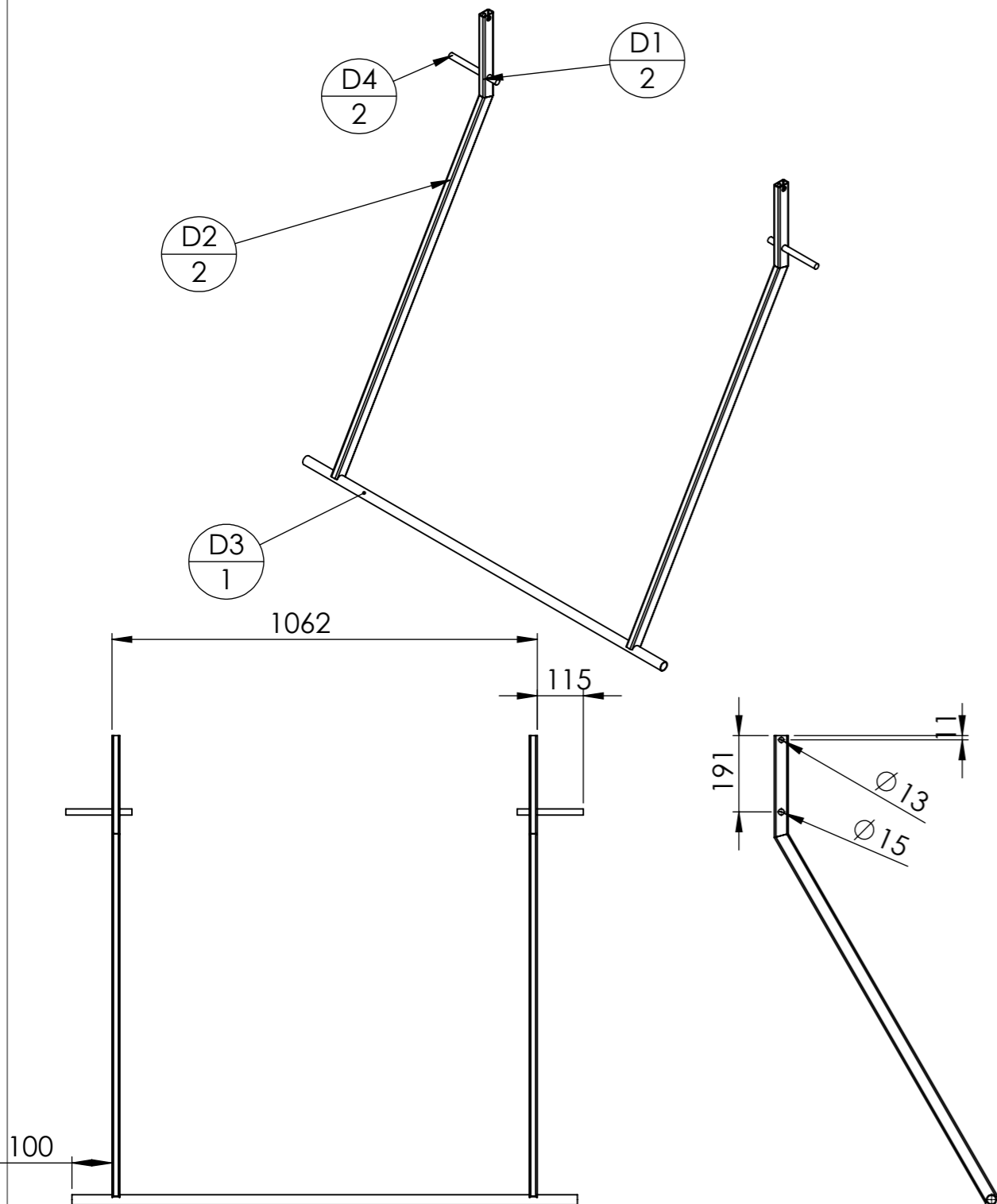

repère	Désignation	ANGLE1	ANGLE2	LONGUEUR	Quantité
D1	tube rectangulaire 35 x 20 x 2	15.00	0.00	255	2
D2	tube rectangulaire 35 x 20 x 2	0.00	15.00	1055	2
D3	tube rond 25 x 2	0.00	0.00	1262	1
D4	étiré rond Ø15	0.00	0.00	165	2

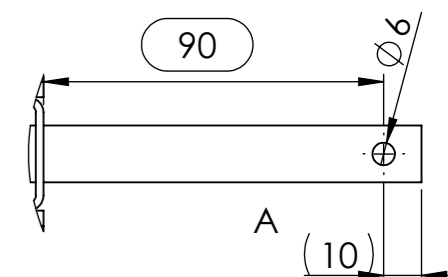
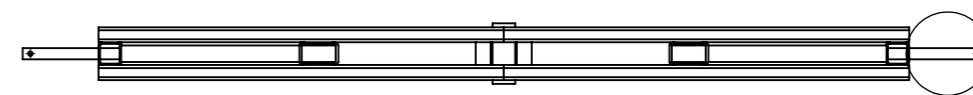
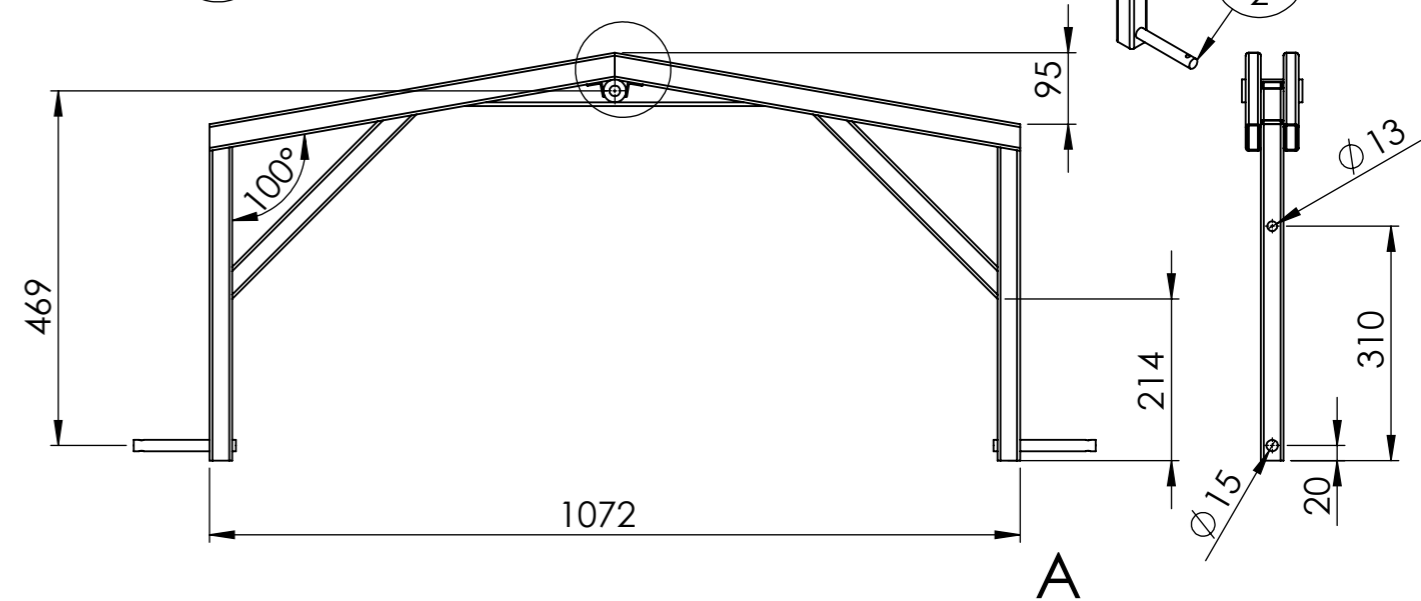
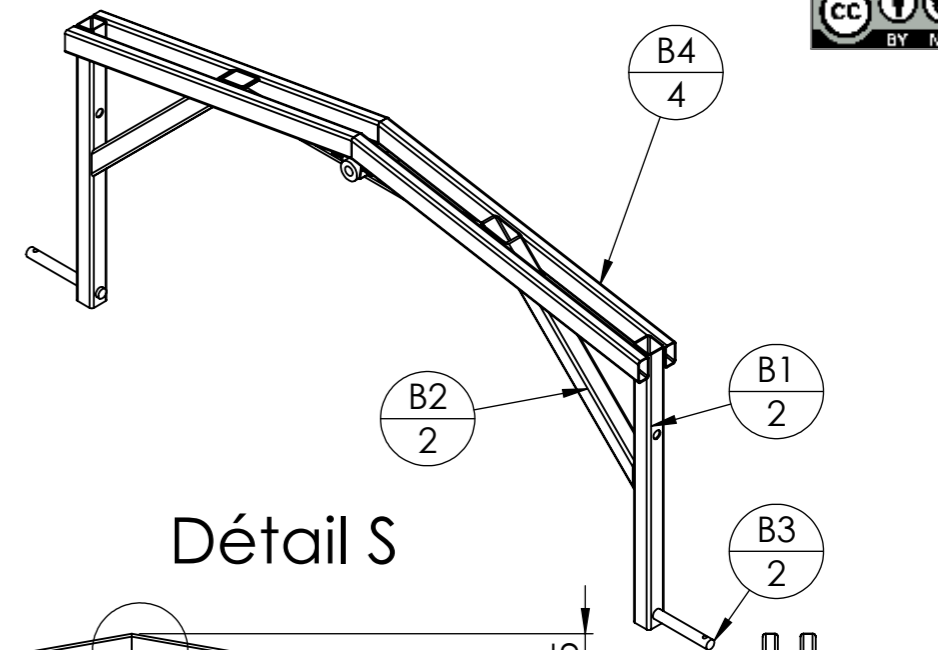
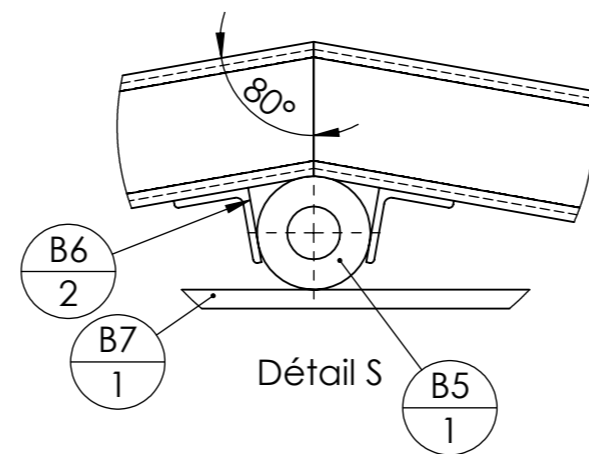

repère	Désignation	ANGLE1	ANGLE2	LONGUEUR	Quantité
B1	Tube carré 30 x 2	0.00	10.00	450	2
B2	Tube carré 30 x 2	55.00	45.00	406	2
B3	étiré rond Ø15	0.00	0.00	135	2
B4	tube rectangulaire 35 x 20 x 2	10.00	10.00	550	4
B5	douille tournée Ø30Ø14.3L80				1
B7	Fer plat 30 x 5	0.00	0.00	492	1
B6	Cornière 20 x 20 x 2	0.00	0.00	70	2

Outil	porte tout			Ech 1:15	A3
Date	10/03/2019	Version	2.0	page n° 4 / 11	
Pièce	B-D larg1200			Qté	1

**L'atelier paysan**

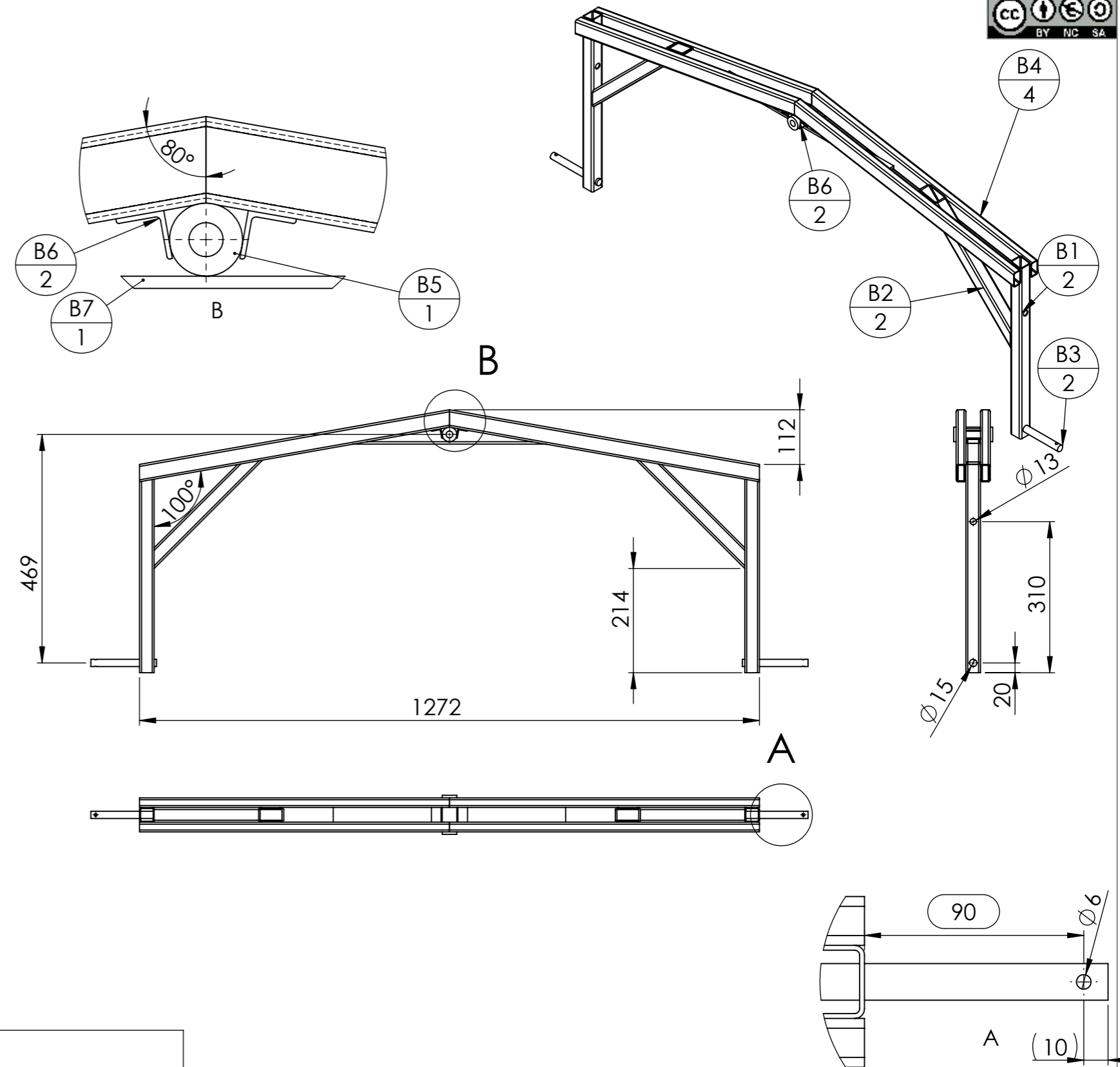
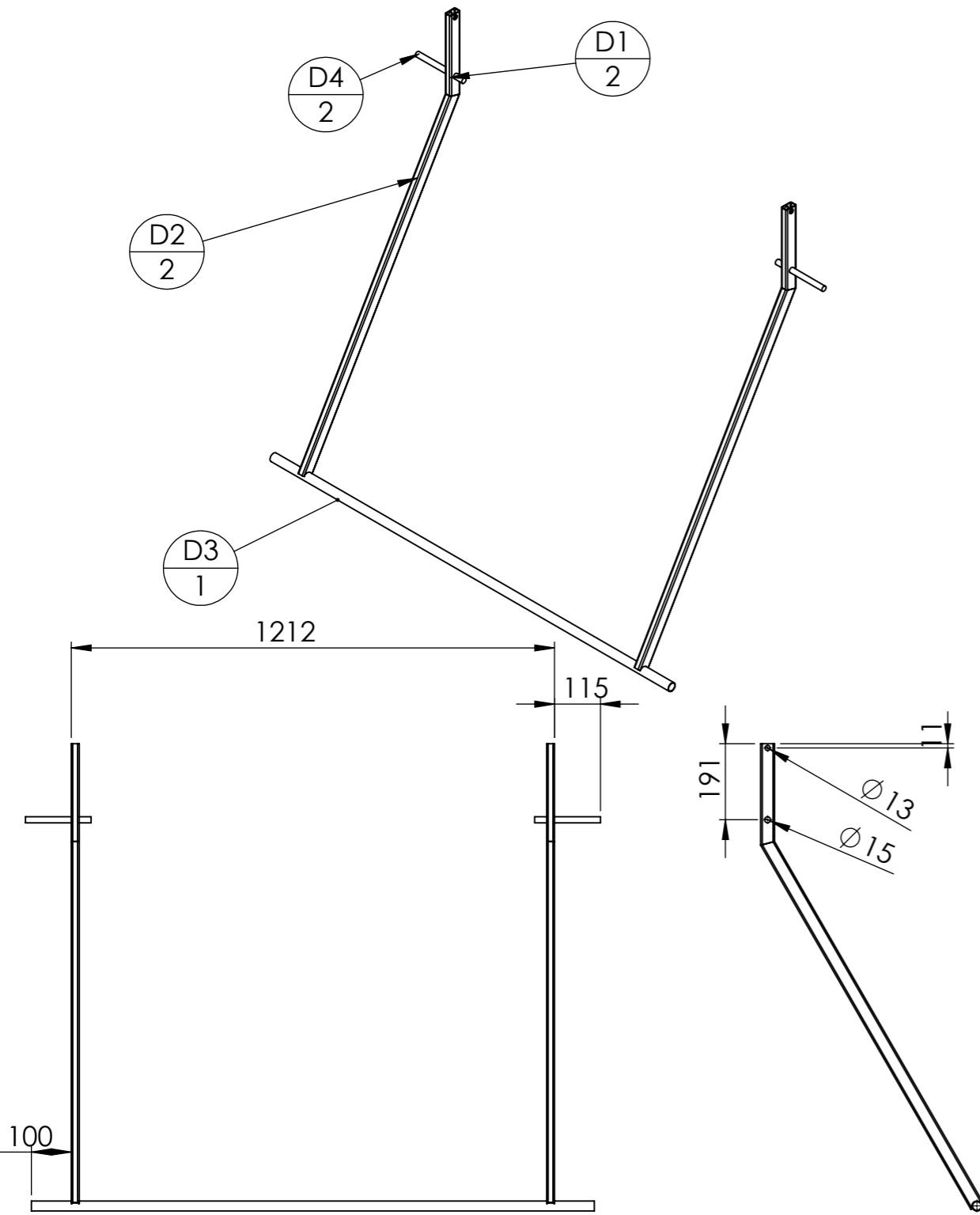

repère	Désignation	ANGLE1	ANGLE2	LONGUEUR	Quantité
D1	tube rectangulaire 35 x 20 x 2	15.00	0.00	255	2
D2	tube rectangulaire 35 x 20 x 2	0.00	15.00	1055	2
D3	tube rond 25 x 2	0.00	0.00	1412	1
D4	étiré rond Ø15	0.00	0.00	165	2

repère	Désignation	ANGLE1	ANGLE2	LONGUEUR	Quantité
B1	Tube carré 30 x 2	0.00	10.00	450	2
B2	Tube carré 30 x 2	55.00	10.00	406	2
B3	étiré rond Ø15	0.00	0.00	135	2
B4	tube rectangulaire 35 x 20 x 2	10.00	0.00	550	4
B5	douille tournée Ø30Ø14.3L80				1
B7	Fer plat 30 x 5	0.00	45.00	492	1
B6	Cornière 20 x 20 x 2	0.00	0.00	70	2

Outil	porte tout		Ech 1:15	A3	
Date	10/03/2019	Version 2.0	page n° 5 / 11		
Pièce	B-D larg1400		Qté	1	

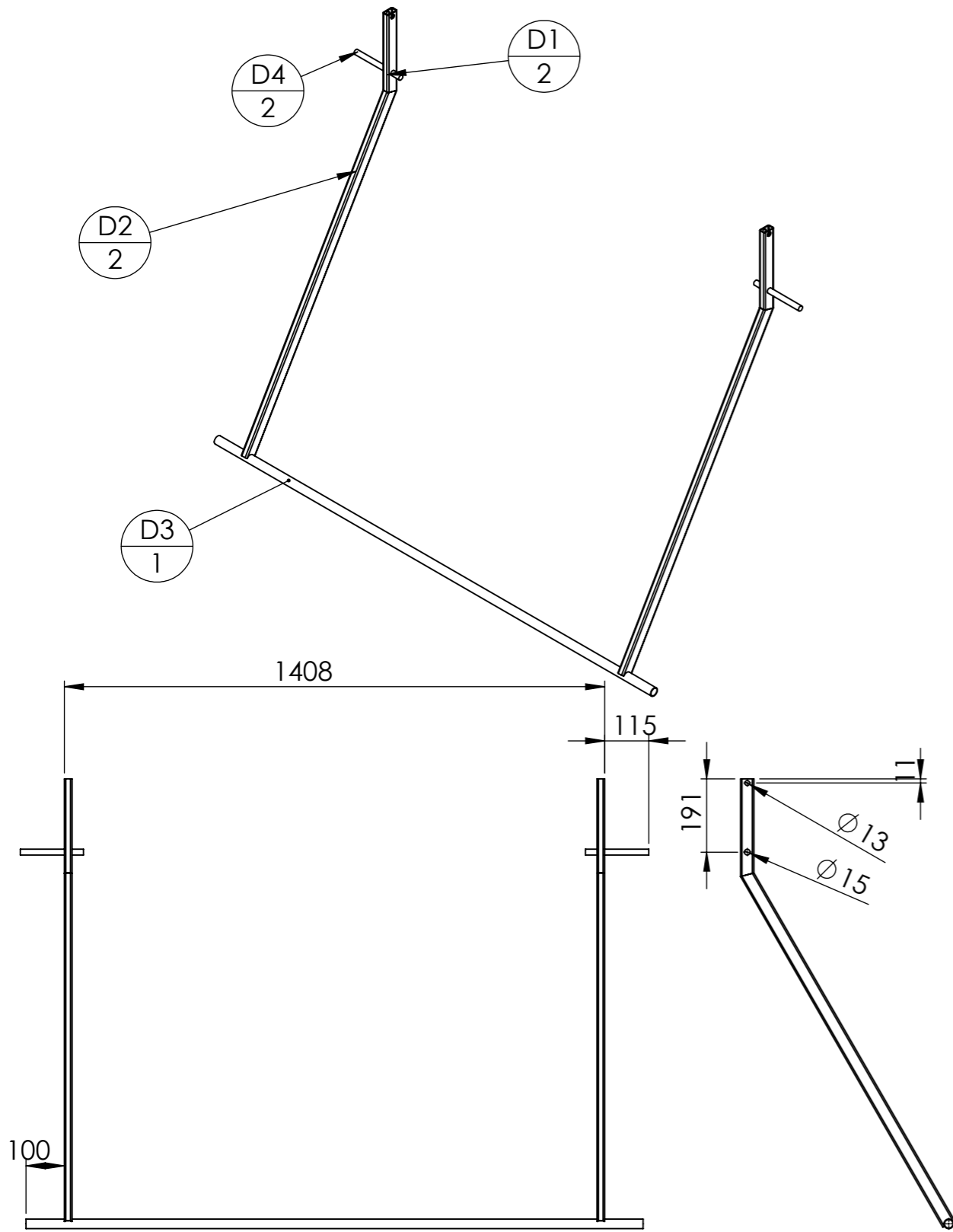

repère	Désignation	ANGLE1	ANGLE2	LONGUEUR	Quantité
D1	tube rectangulaire 35 x 20 x 2	15.00	0.00	255	2
D2	tube rectangulaire 35 x 20 x 2	0.00	15.00	1055	2
D3	tube rond 25 x 2	0.00	0.00	1412	1
D4	étiré rond Ø15	0.00	0.00	165	2

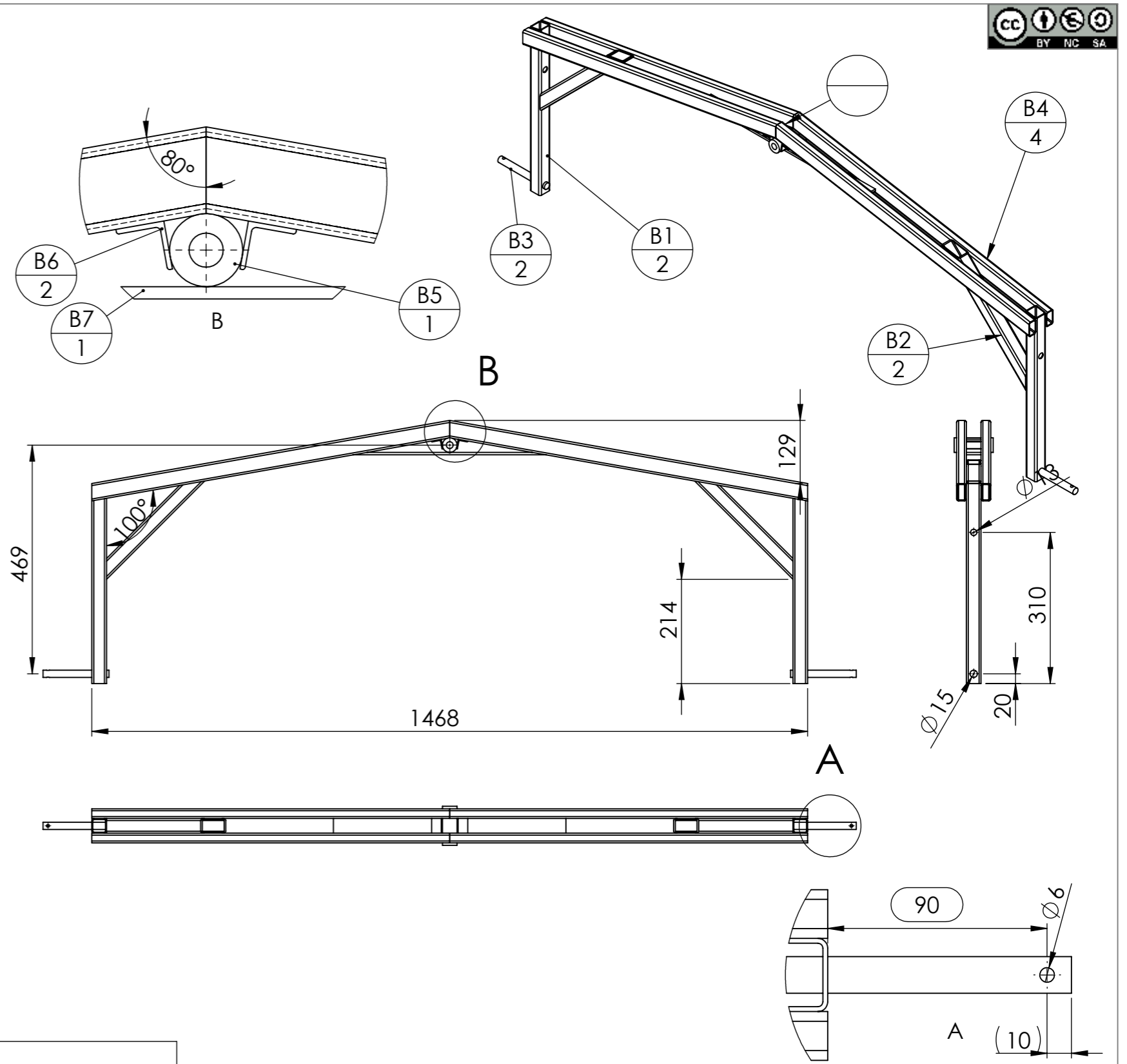

repère	Désignation	ANGLE1	ANGLE2	LONGUEUR	Quantité
B1	Tube carré 30 x 2	0.00	10.00	450	2
B2	Tube carré 30 x 2	55.00	45.00	406	2
B3	étiré rond Ø15	0.00	0.00	135	2
B4	tube rectangulaire 35 x 20 x 2	10.00	10.00	550	4
B5	douille tournée Ø30Ø14.3L80				1
B7	Fer plat 30 x 5	0.00	0.00	492	1
B6	Cornière 20 x 20 x 2	0.00	0.00	70	2

repère	Désignation	ANGLE1	ANGLE2	LONGUEUR	Qté
A1	tube rectangulaire 35 x 20 x 2	0.00	0.00	1820	2
A2	tube rectangulaire 35 x 20 x 2	0.00	0.00	1218	5
A3	TOLE 12/10 EZ 1812 x 1250				1
A4	fer plat 16 x 4	0.00	0.00	1820	2
A5	fer plat 16 x 4	0.00	0.00	1250	2
A6	Tube carré 30 x 2	0.00	0.00	51	12
A7	Cornière 30 x 3	0.00	0.00	430	2
A9	Tube carré 30 x 2	0.00	-	585	2
A8	fer plat 40 x 5	0.00	0.00	100	1
A10	étiré rond Ø15	0.00	0.00	135	2
A11	Tube carré 20 x 2	45.00	45.00	465	2
A12	Tube carré 30 x 2	0.00	0.00	50	4
A15	Tube carré 30 x 2	0.00	0.00	44	2
A14	Tube carré 20 x 2	45.00	45.00	642	2

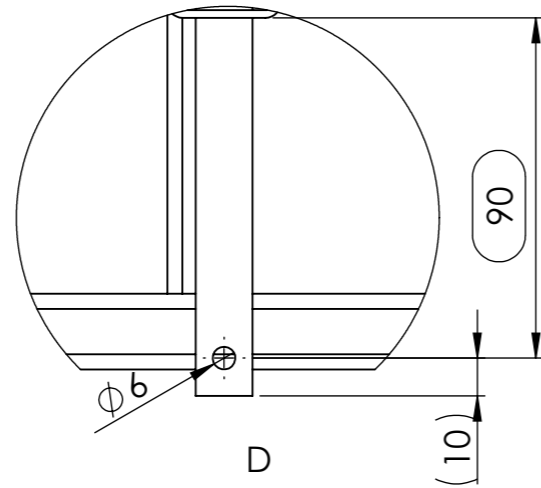
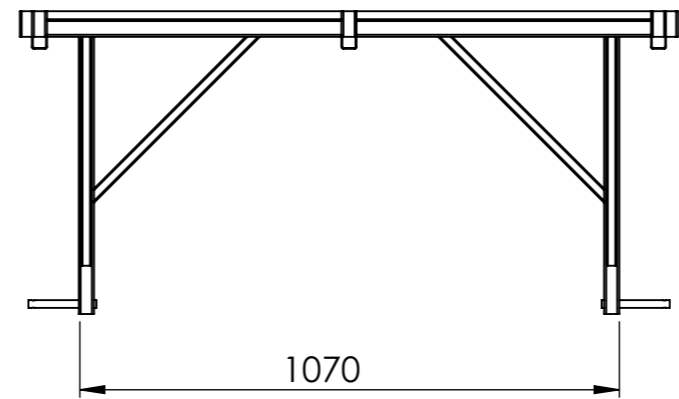
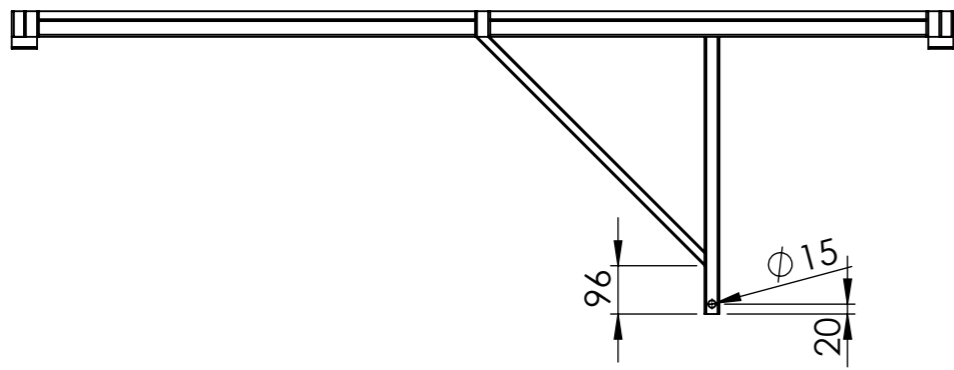
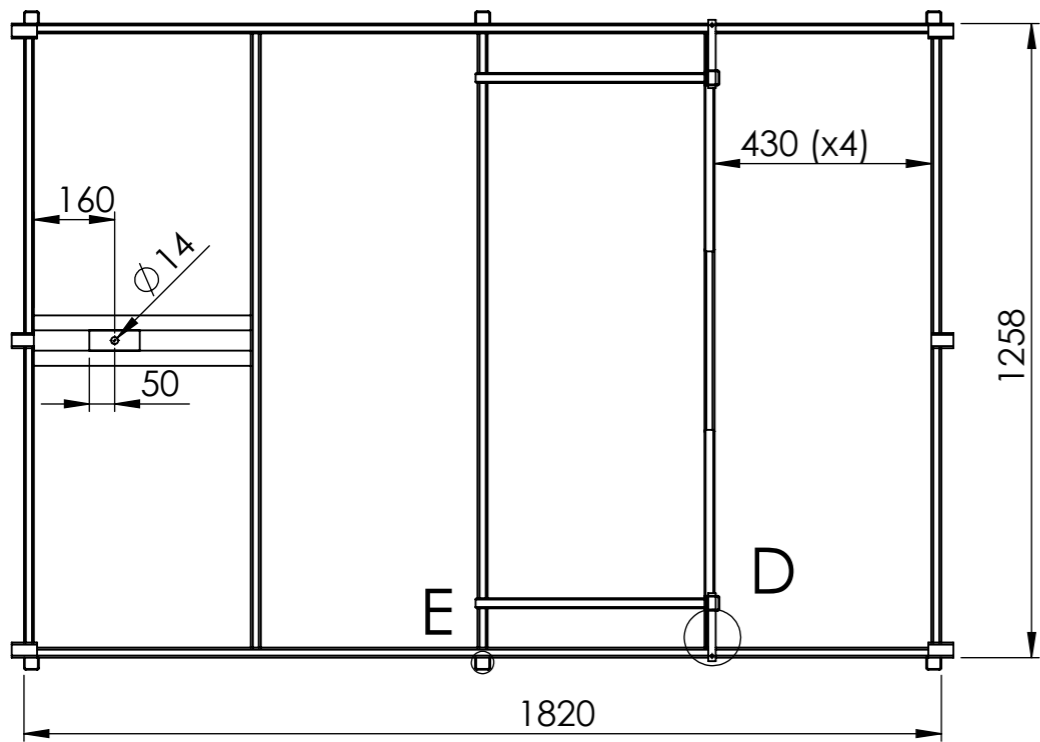

tous les supports de ridelles sont des tubes recoupés

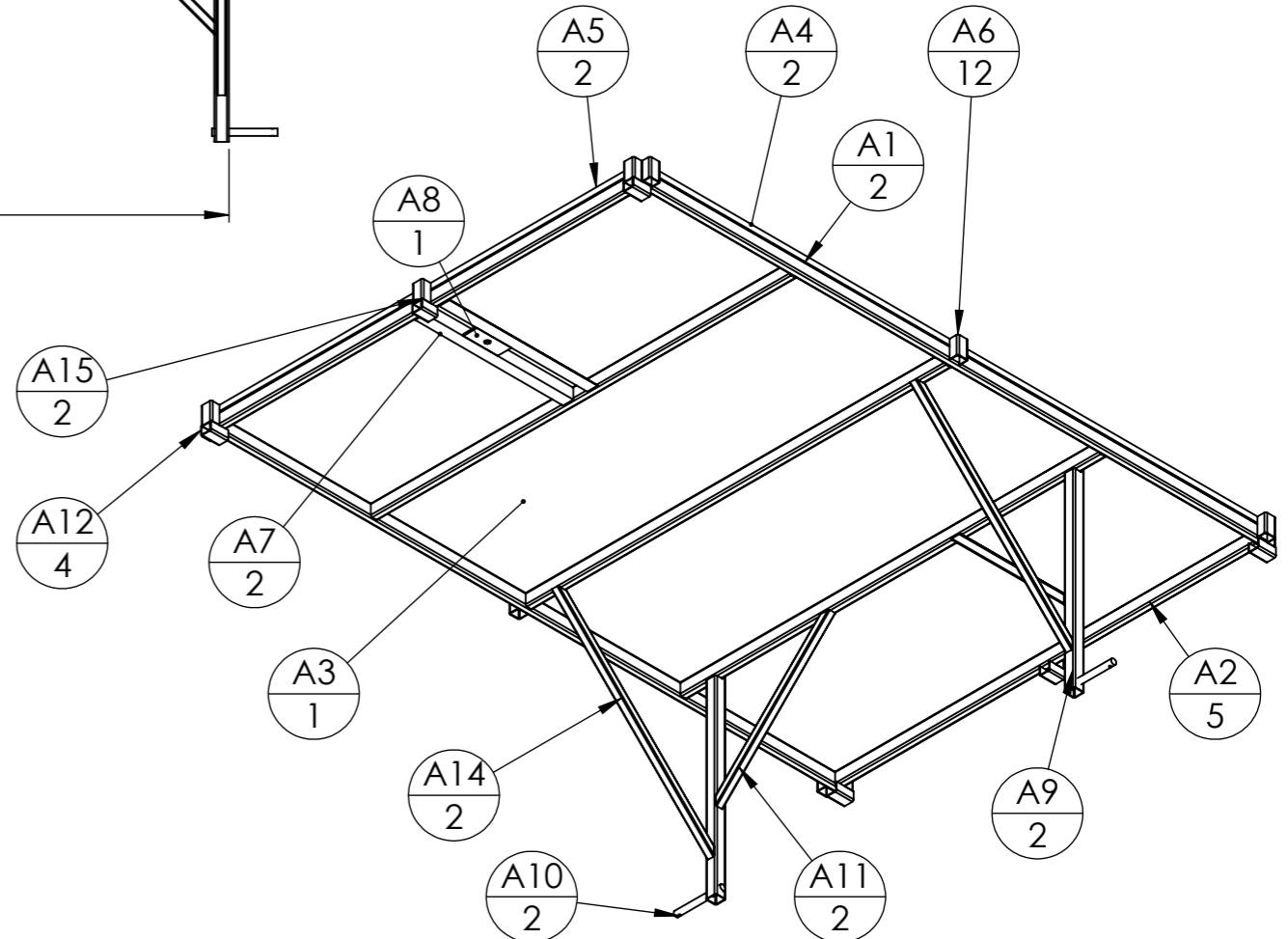
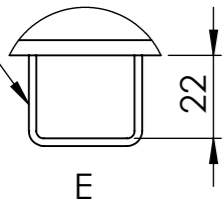

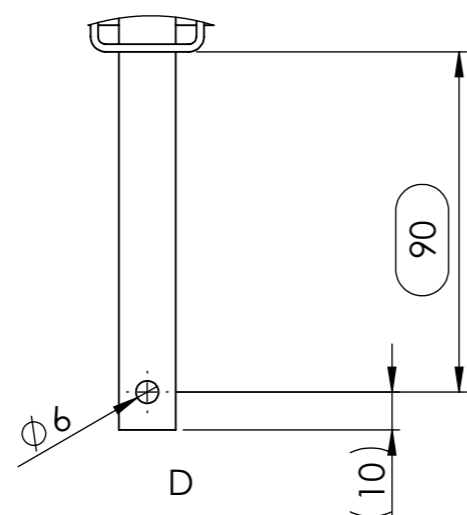
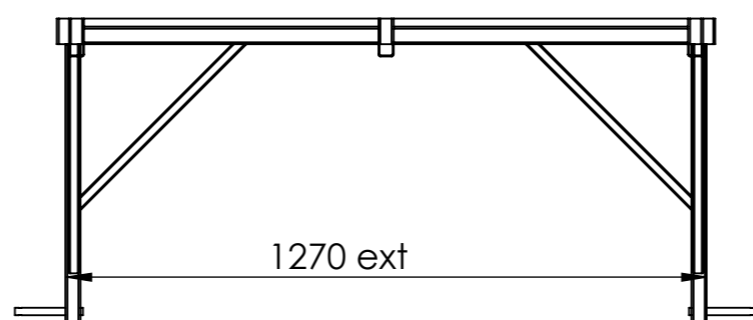
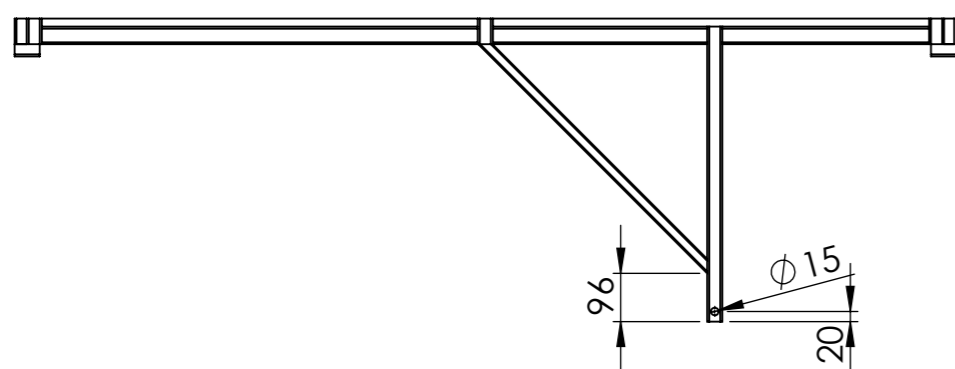
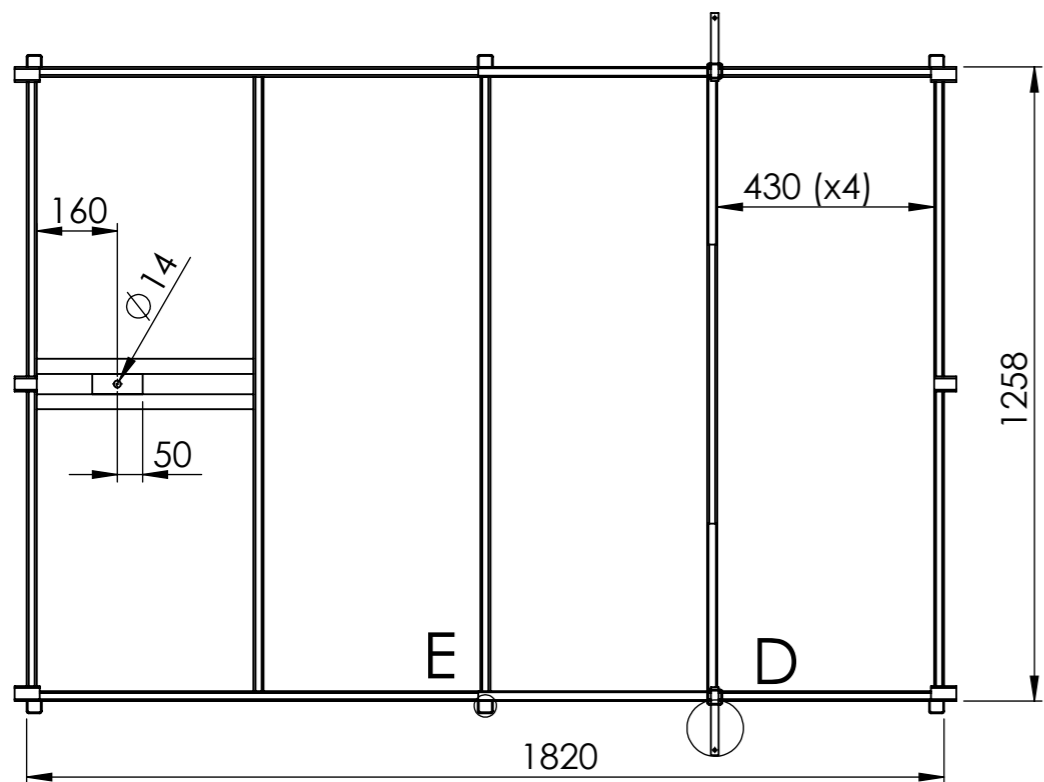

tous les supports de ridelles sont des tubes recoupés

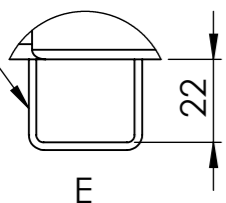

repère	Désignation	ANGLE 1	ANGLE 2	LONGUEUR	Qté
A1	tube rectangulaire 35 x 20 x 2	0.00	0.00	1820	2
A2	tube rectangulaire 35 x 20 x 2	0.00	0.00	1218	5
A3	TOLE 12/10 EZ 1812 x 1250				1
A4	fer plat 16 x 4	0.00	0.00	1820	2
A5	fer plat 16 x 4	0.00	0.00	1250	2
A6	Tube carré 30 x 2	0.00	0.00	51	12
A7	Cornière 30 x 3	0.00	0.00	430	2
A9	Tube carré 30 x 2	-	0.00	585	1
A10	étiré rond Ø15	0.00	0.00	135	2
A11	Tube carré 20 x 2	45.00	45.00	465	2
A12	Tube carré 30 x 2	0.00	0.00	50	4
A15	Tube carré 30 x 2	0.00	0.00	44	2
A14	Tube carré 20 x 2	45.00	45.00	642	2
A8	fer plat 40 x 5	0.00	0.00	100	1
A13	Tube carré 30 x 2	-	0.00	585	1

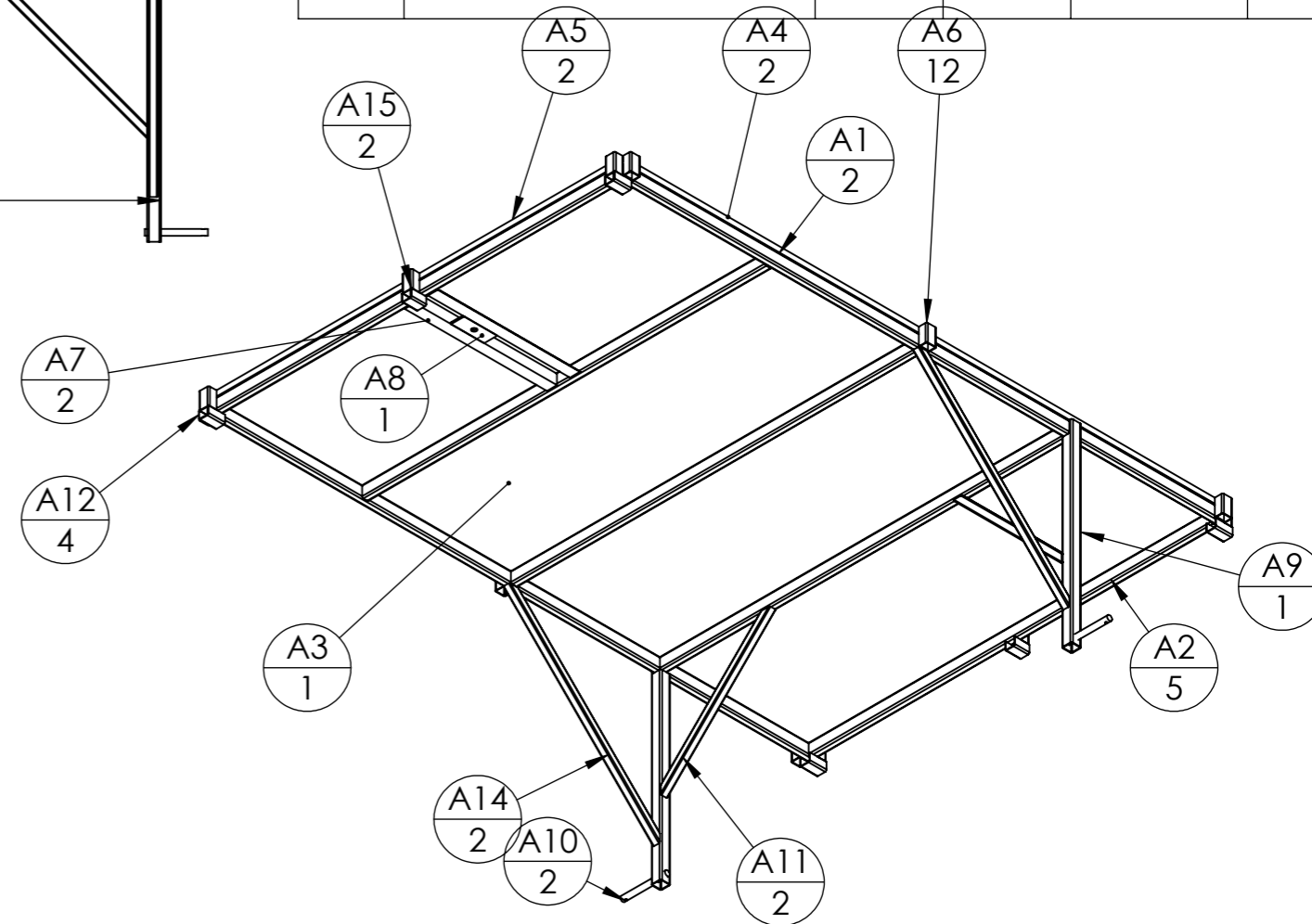

repère	Désignation	ANGLE1	ANGLE2	LONGUEUR	Qté
A1	tube rectangulaire 35 x 20 x 2	0.00	0.00	1820	2
A2	tube rectangulaire 35 x 20 x 2	0.00	0.00	1468	5
A3	TOLE 12/10 EZ 1812 x 1500				1
A4	fer plat 16 x 4	0.00	0.00	1820	2
A5	fer plat 16 x 4	0.00	0.00	1500	2
A6	Tube carré 30 x 2	0.00	0.00	51	12
A7	Cornière 30 x 3	0.00	0.00	430	2
A9	Tube carré 30 x 2	0.00	-	585	2
A10	étiré rond Ø15	0.00	0.00	135	2
A11	Tube carré 20 x 2	45.00	45.00	465	2
A12	Tube carré 30 x 2	0.00	0.00	50	4
A15	Tube carré 30 x 2	0.00	0.00	44	2
A14	Tube carré 20 x 2	45.00	45.00	642	2
A8	fer plat 40 x 5	0.00	0.00	100	1

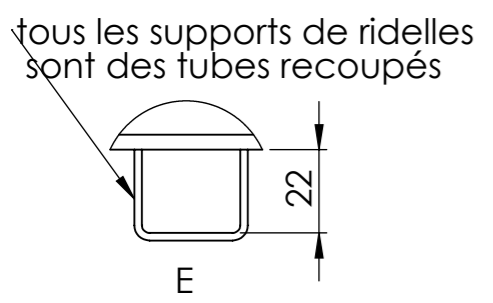
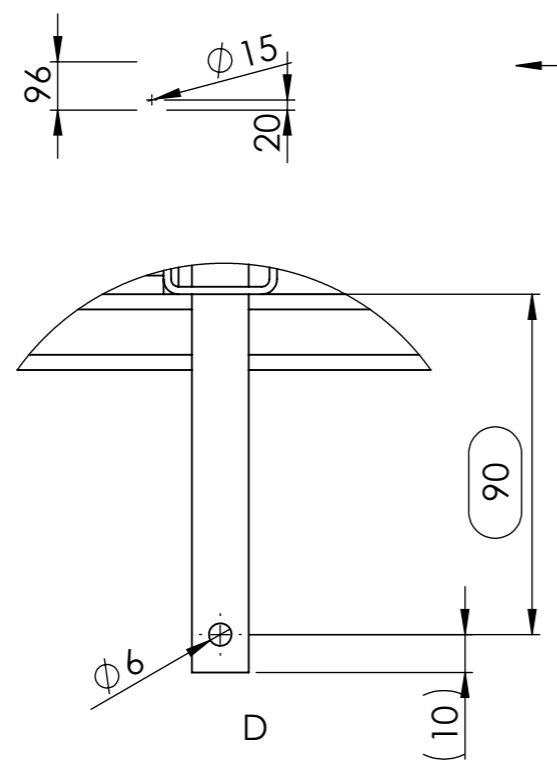
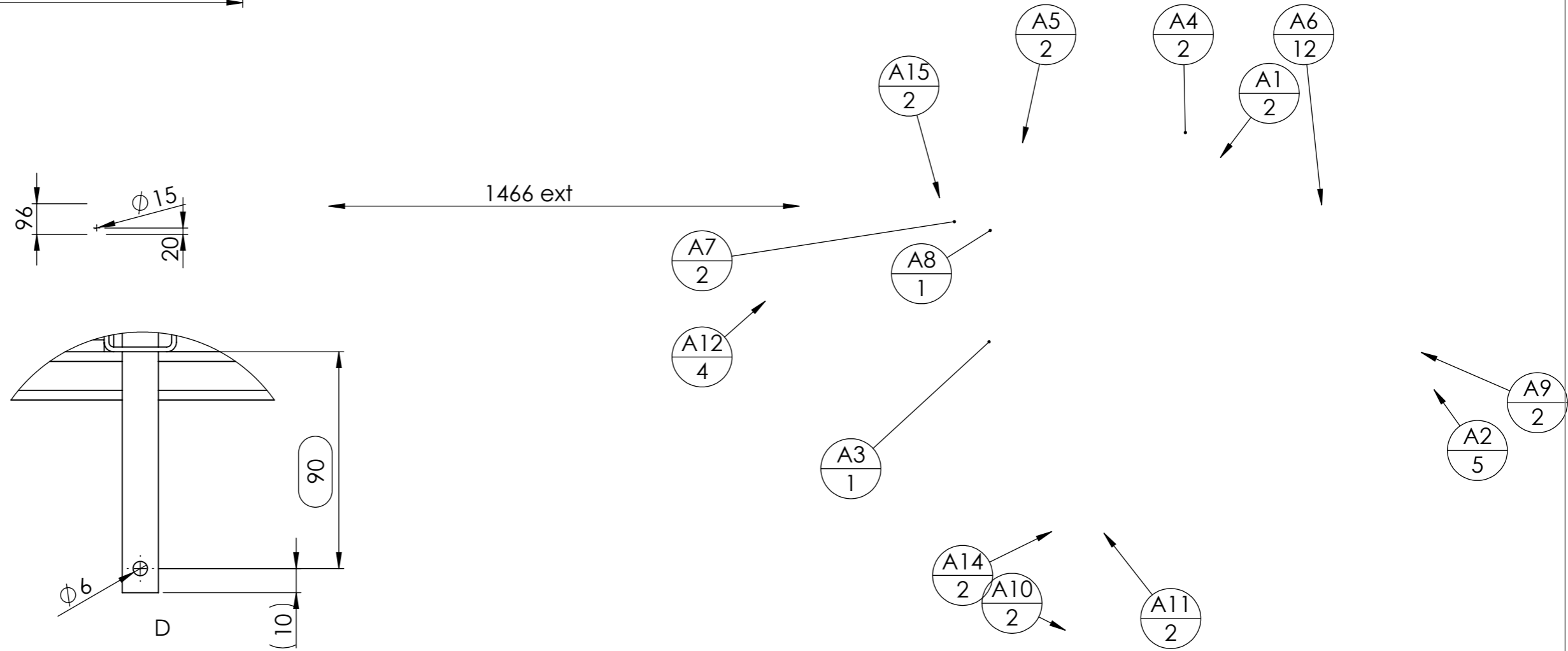
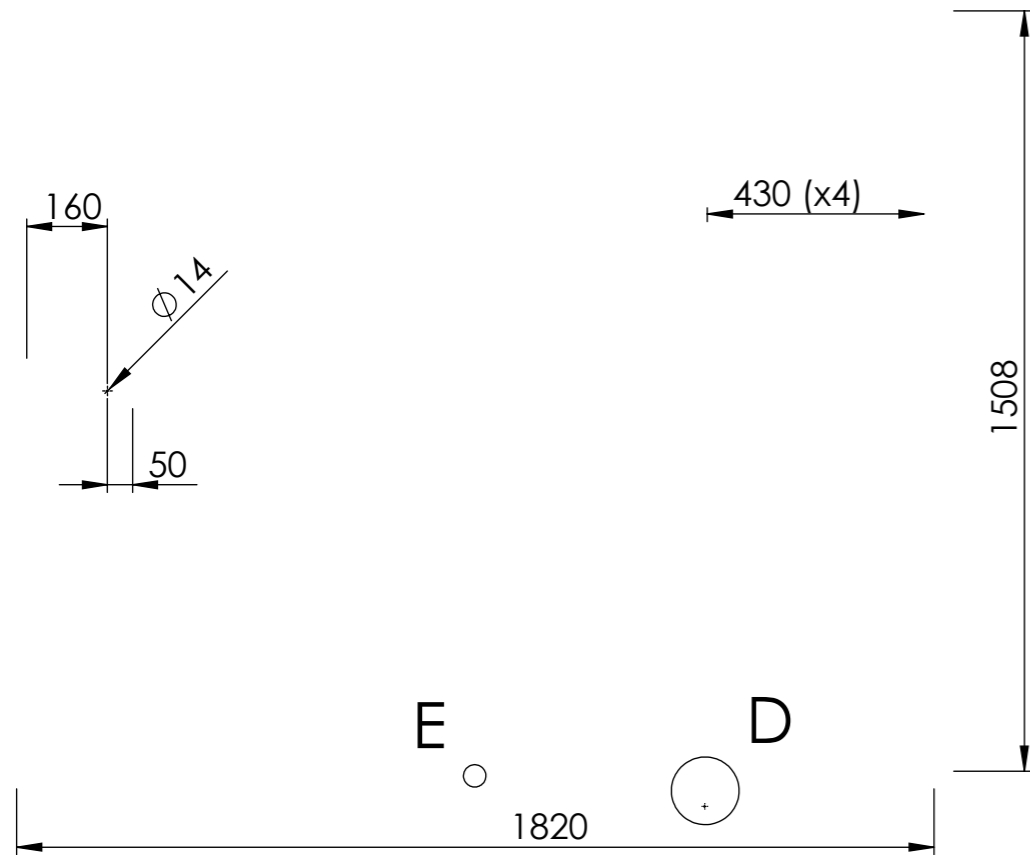

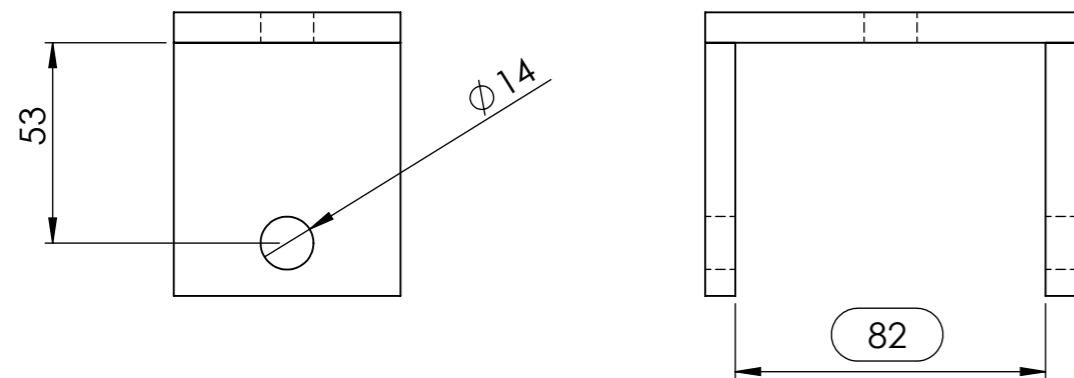
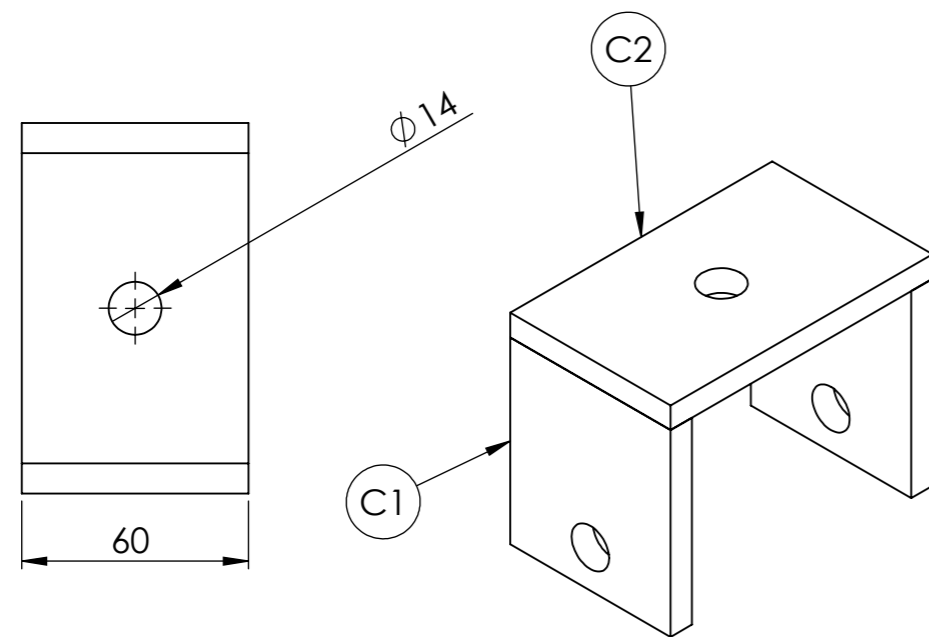
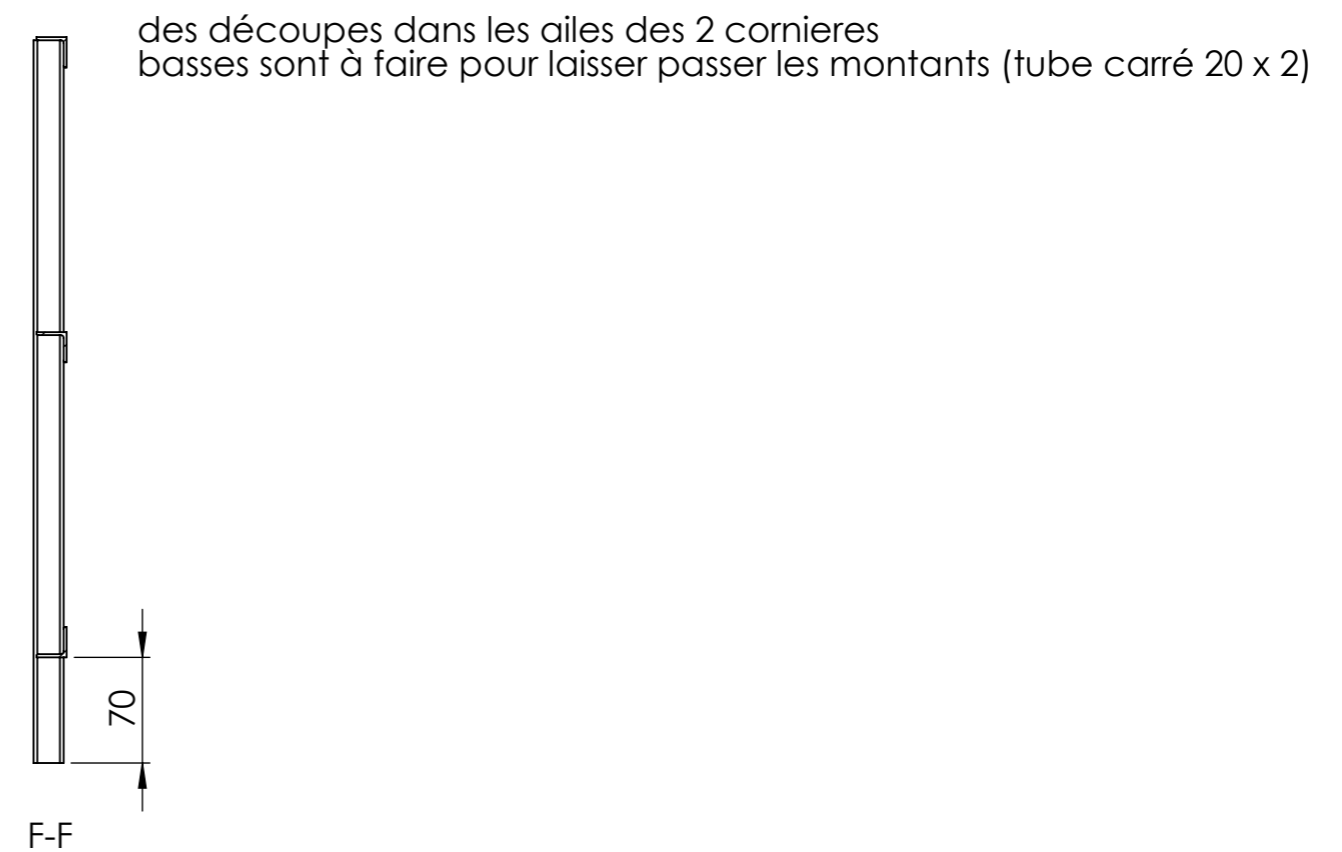
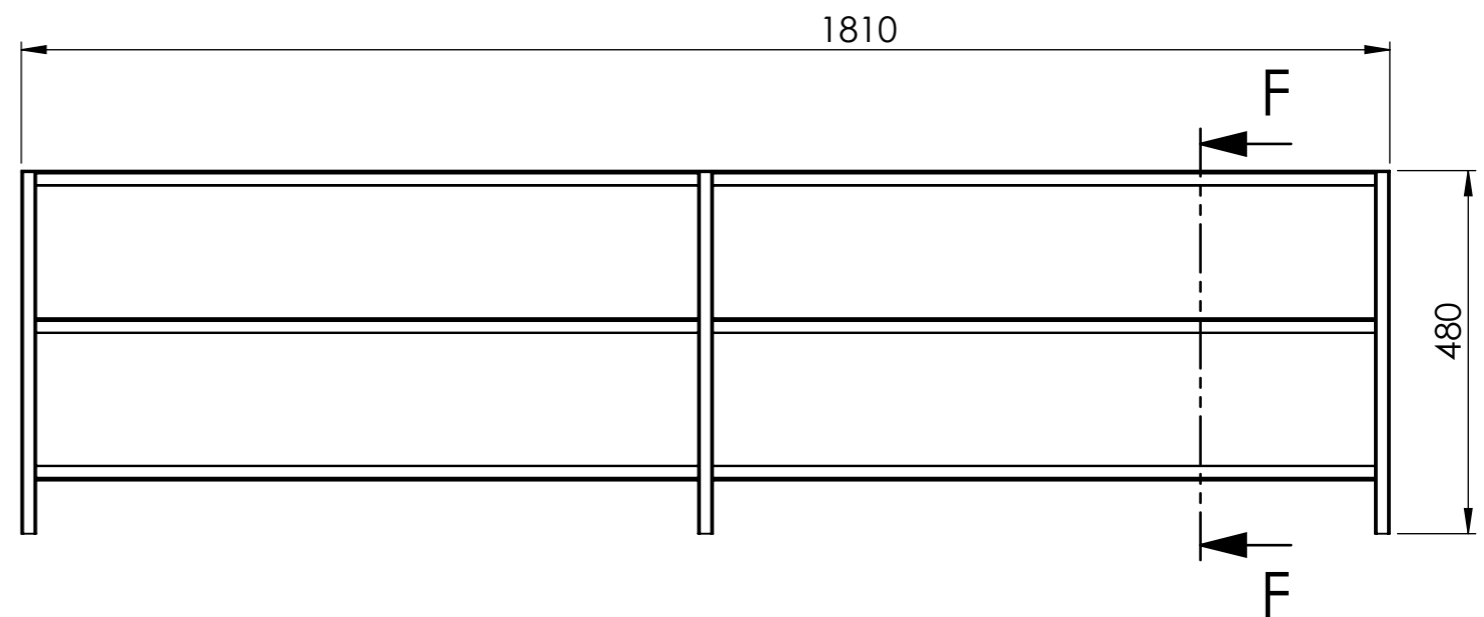
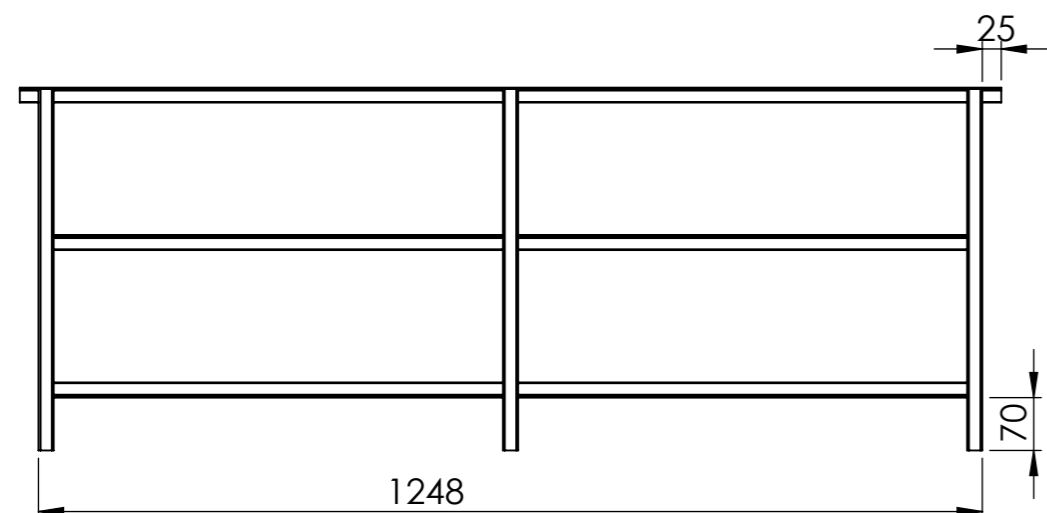

Table de nomenclature(restructuré)			
repère	Désignation	LONGUEUR	Quantité
C1	Fer plat 60 x 8	67	2
C2	Fer plat 60 x 8	98	1

Table de nomenclature(restructuré)			
repère	Désignation	LONGUEUR	Quantité
E1	Tube carré 20 x 2	478	3
E2	Cornière 20 x 20 x 2	1810	1
E3	Cornière 20 x 20 x 2	1810	2



Outil	porte tout				
Date	10/03/2019	Version	2.0		page n° 10 / 11
Feuille	ridelle F				



largeur 1000 et 1200

Table de nomenclature(restructuré)			
repère	Désignation	LONGUEUR	Quantité
F1	Cornière 20 x 20 x 2	1298	1
F2	Cornière 20 x 20 x 2	1248	2
F3	Tube carré 20 x 2	478	3

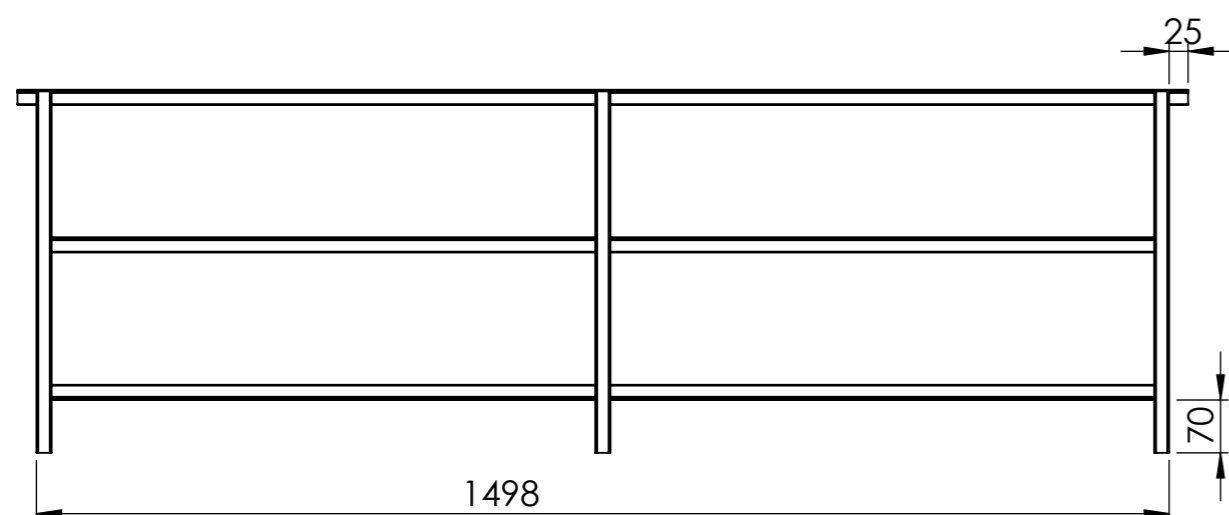

largeur 1400

repère	Désignation	LONGUEUR	Quantité
F1	Cornière 20 x 20 x 2	1548	1
F2	Cornière 20 x 20 x 2	1498	2
F3	Tube carré 20 x 2	478	3

Outil	porte tout				
Date	10/03/2019	Version	2.0	page n° 11 / 11	
Pièce	Contributions			Qté	



Les travaux pour réaliser la présente mise à jour ont bénéficié d'une contribution des collectivités publiques :



Cette action est cofinancée par le Fonds européen agricole pour le développement rural : l'Europe investit dans les zones rurales.



Cette mise à jour, comme les précédentes, a bénéficié de la contribution bénévole et décisive des nombreux(ses) paysan(ne)s, membres formels ou informels du collectif L'Atelier paysan.

Un remerciement particulier pour la ferme de Belêtre, réalisateur du prototype