

| repère | Désignation | ANGLE1 | ANGLE2 | p | LONGUEUR | Quantité |
|--------|---------------------|--------|--------|------------|----------|----------|
| A8 | A8 épandeur compost | 0° | - | 1x Ø20,5 ; | | 1 |

| | | | | |
|---------|------------|---------|---------------|---|
| Outil | A13 | | |  |
| Date | 01/07/2022 | Version | page n° 1 / 1 | |
| Feuille | Feuille 1 | | | |

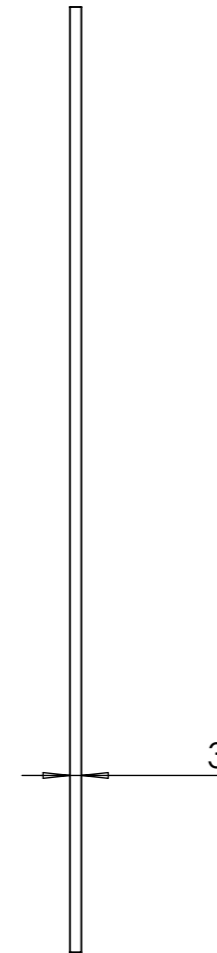
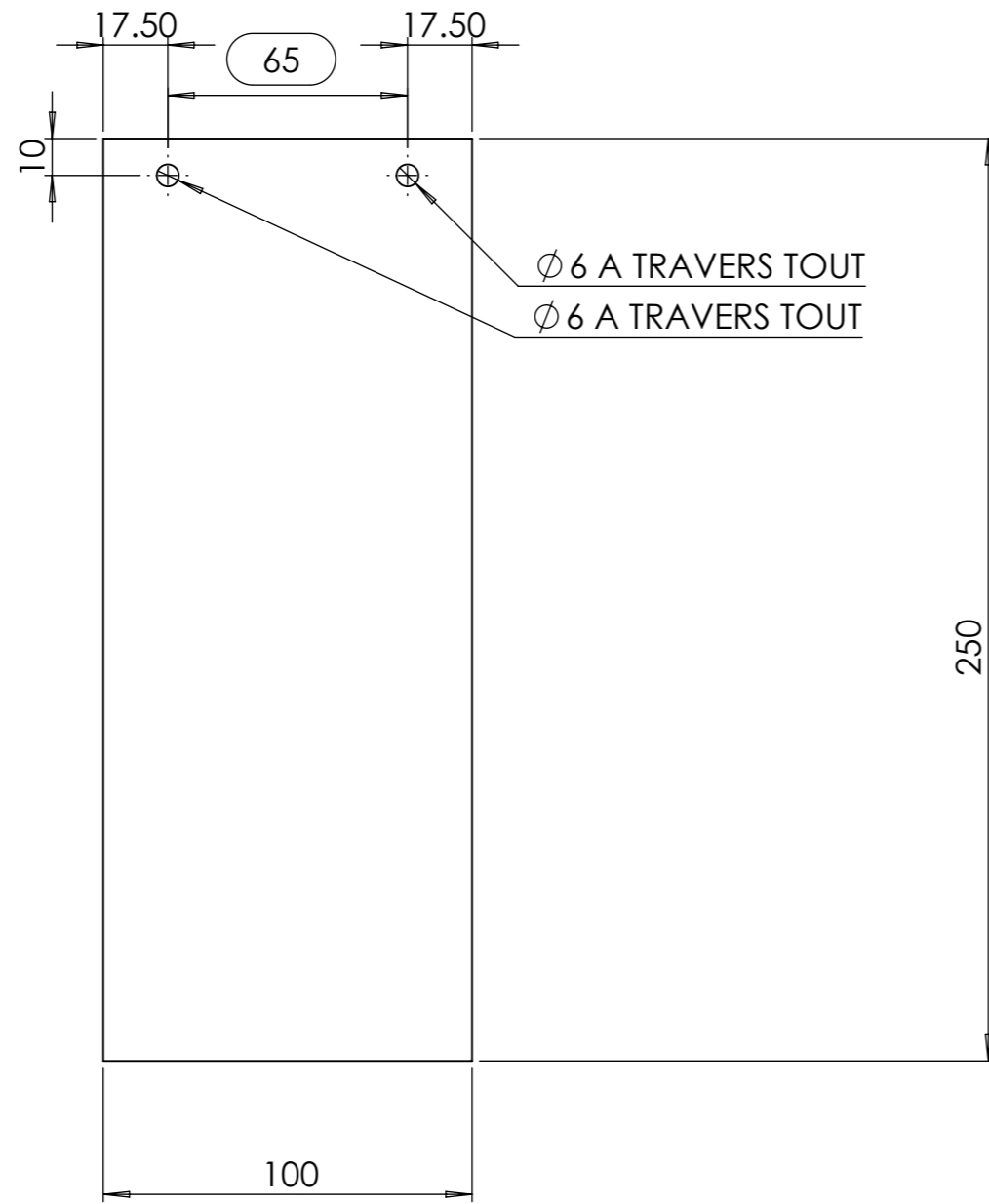

| repère | Désignation | ANGLE1 | ANGLE2 | p | LONGUEUR | Quantité |
|--------|----------------------|--------|--------|---------------|----------|----------|
| A13 | A13 épandeur compost | | | 2x $\phi 6$; | SPE | 1 |

| | | | | |
|---------|------------------|---------|---------------|---|
| Outil | A16 | | |  |
| Date | 01/07/2022 | Version | page n° 1 / 1 | |
| Feuille | Feuille 1 | | | |

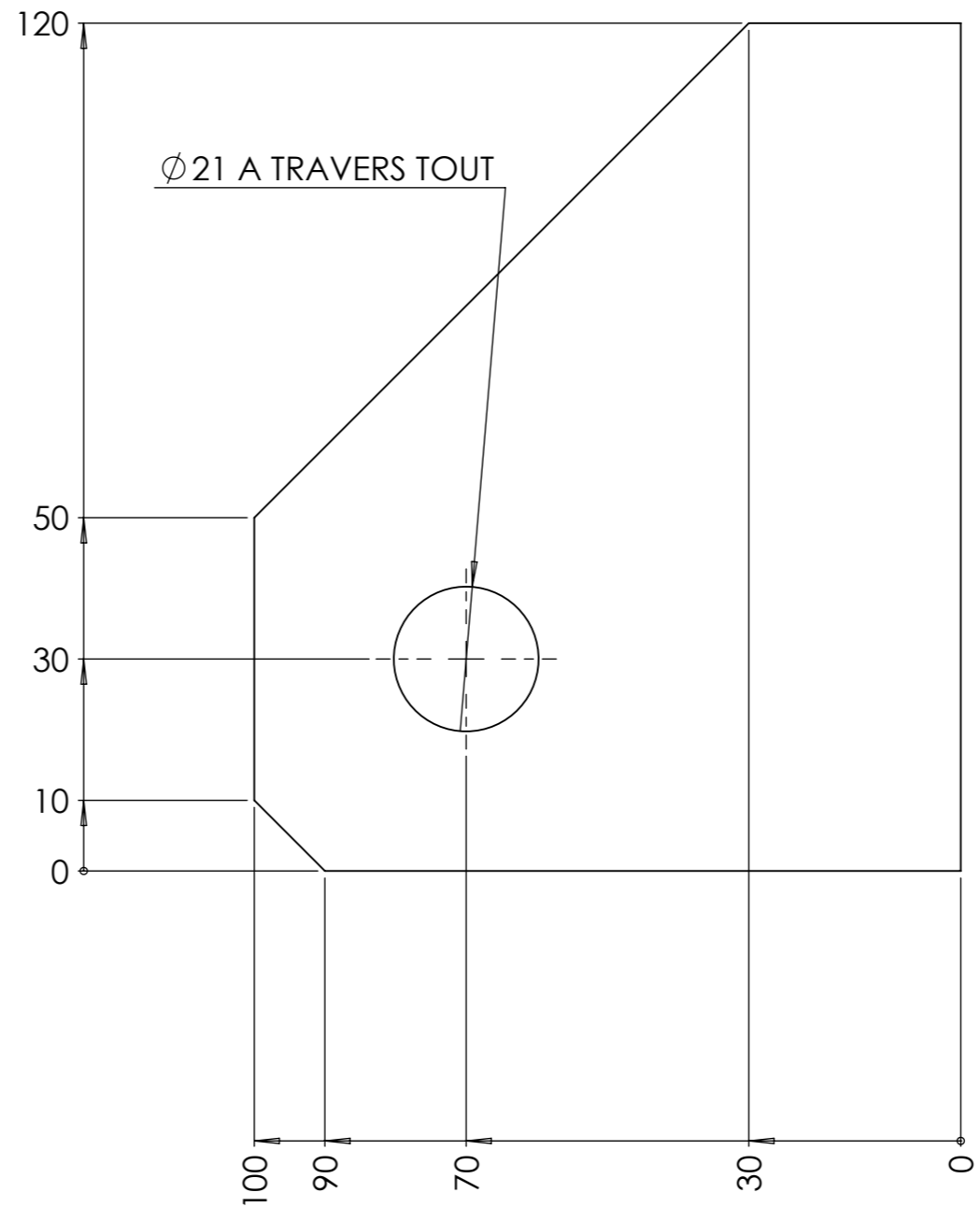

| repère | Désignation | ANGLE1 | ANGLE2 | p | LONGUEUR | Quantité |
|--------|----------------------|--------|--------|------------|----------|----------|
| A16 | A16 épandeur compost | 0° | 0° | 1x Ø20,5 ; | | 1 |

| | | | | | |
|---------|------------|---------|-----|---|---------------|
| Outil | AB1 | | |  | |
| Date | 01/07/2022 | Version | 1.3 | | page n° 1 / 1 |
| Feuille | Feuille 1 | | | | |

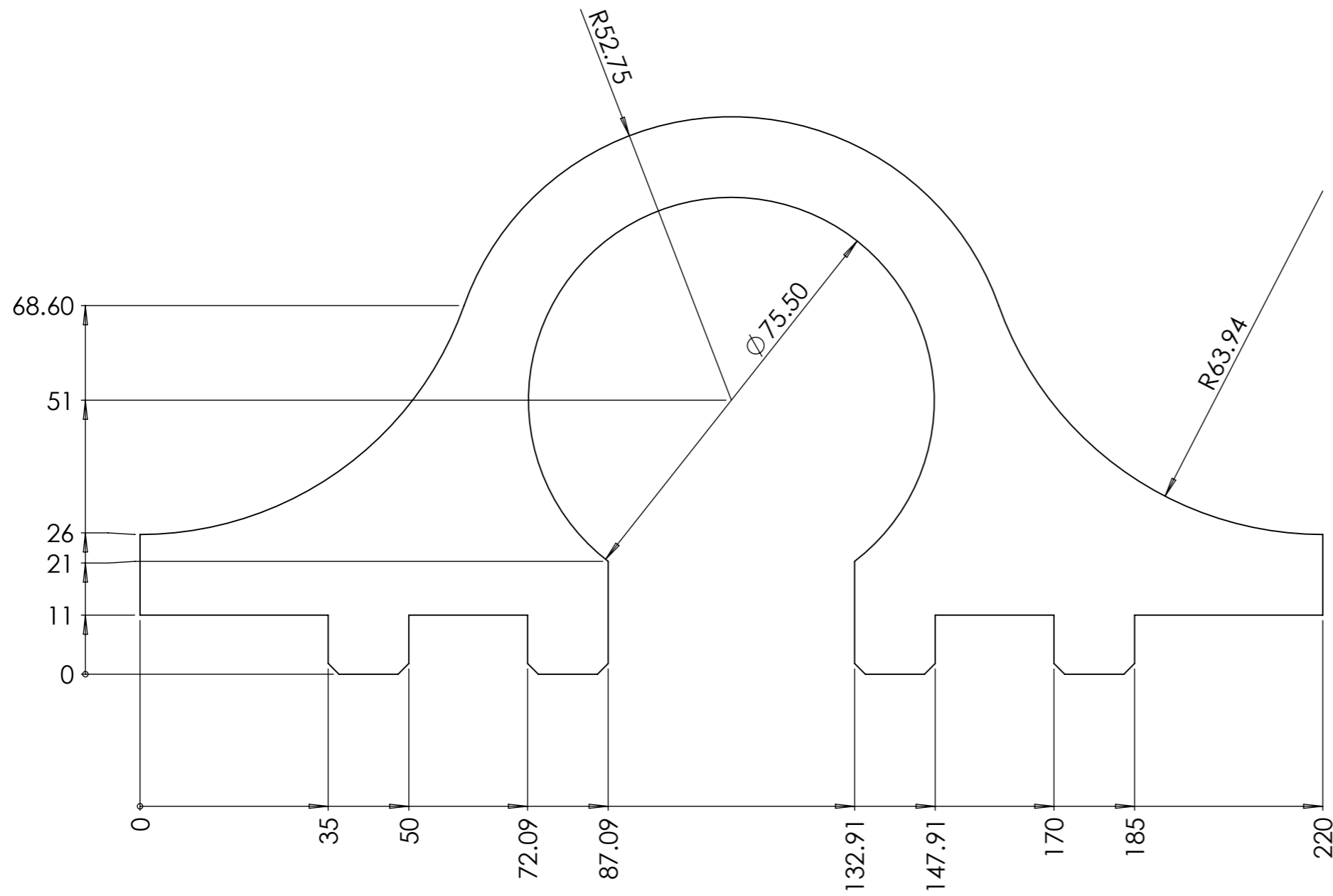

| repère | Désignation | ANGLE1 | ANGLE2 | p | LONGUEUR | Epaisseur de tôlerie | Matériau | Quantité |
|--------|----------------------|--------|--------|---|----------|----------------------|-----------------|----------|
| AB1 | AB1 épandeur compost | | | | | 0.015 | Acier non allié | 1 |

| | | | | |
|---------|------------|---------|--|---|
| Outil | AB3 | | |  |
| Date | 01/07/2022 | Version | | |
| Feuille | Feuille 1 | | | |

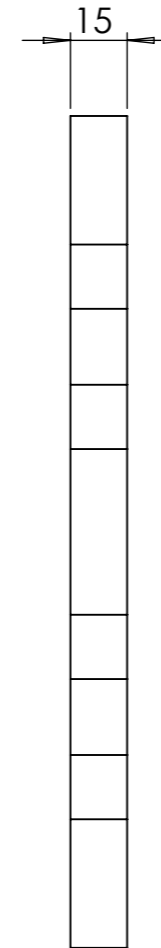
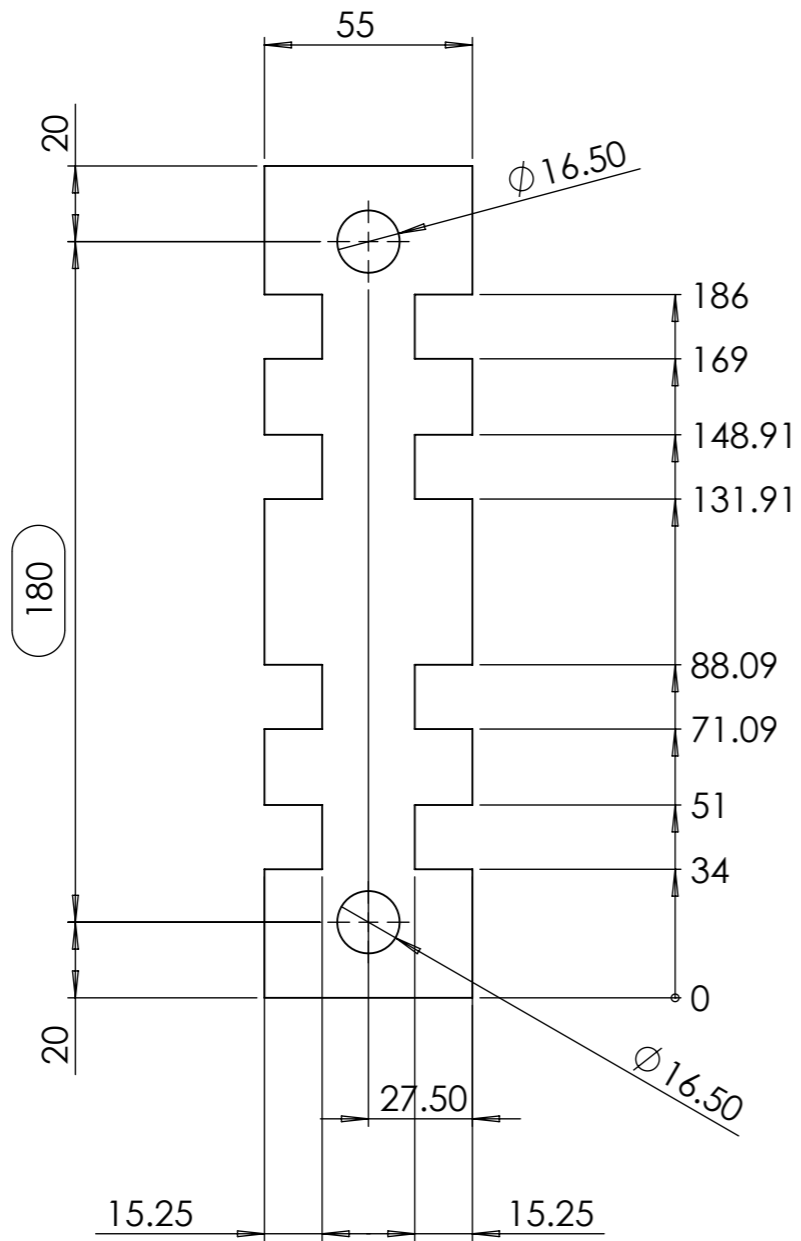

| repère | Désignation | ANGLE1 | ANGLE2 | p | LONGUEUR | Quantité |
|--------|----------------------|--------|--------|------------|----------|----------|
| AB3 | AB3 épandeur compost | | | 2x Ø16,5 ; | SPE | 1 |

| | | | | |
|---------|------------------|---------|---------------|-----------------------------|
| Outil | B1 | | | L'atelier paysan |
| Date | 01/07/2022 | Version | page n° 1 / 1 | |
| Feuille | Feuille 1 | | | |

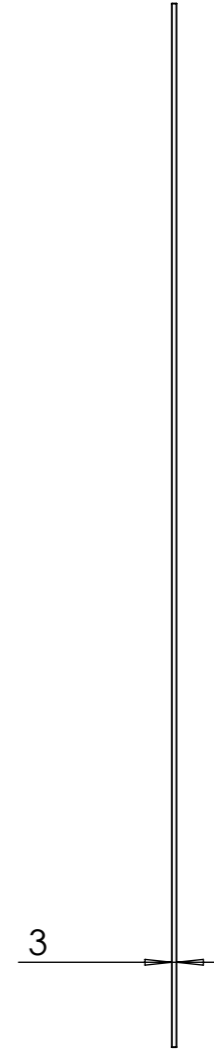
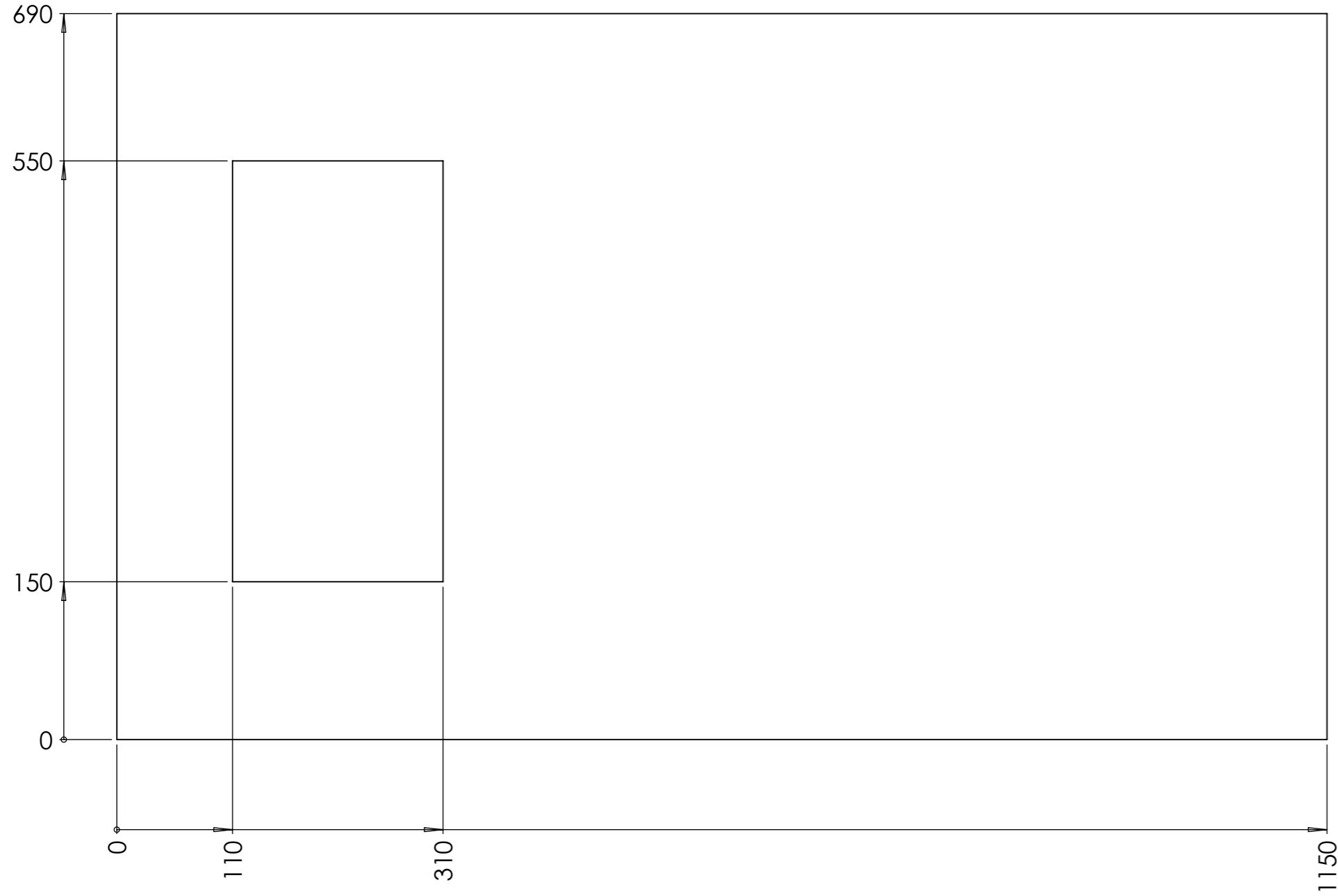

| repère | Désignation | ANGLE1 | ANGLE2 | p | LONGUEUR | Epaisseur de tôlerie | Matériau | Quantité |
|--------|---------------------|--------|--------|---|----------|----------------------|-----------------|----------|
| B1 | B1 épandeur compost | | | | | 0.003 | Acier non allié | 1 |

| | | | | |
|---------|------------------|---------|---------------|---|
| Outil | B2 | | |  |
| Date | 07/12/2022 | Version | page n° 1 / 1 | |
| Feuille | Feuille 1 | | | |

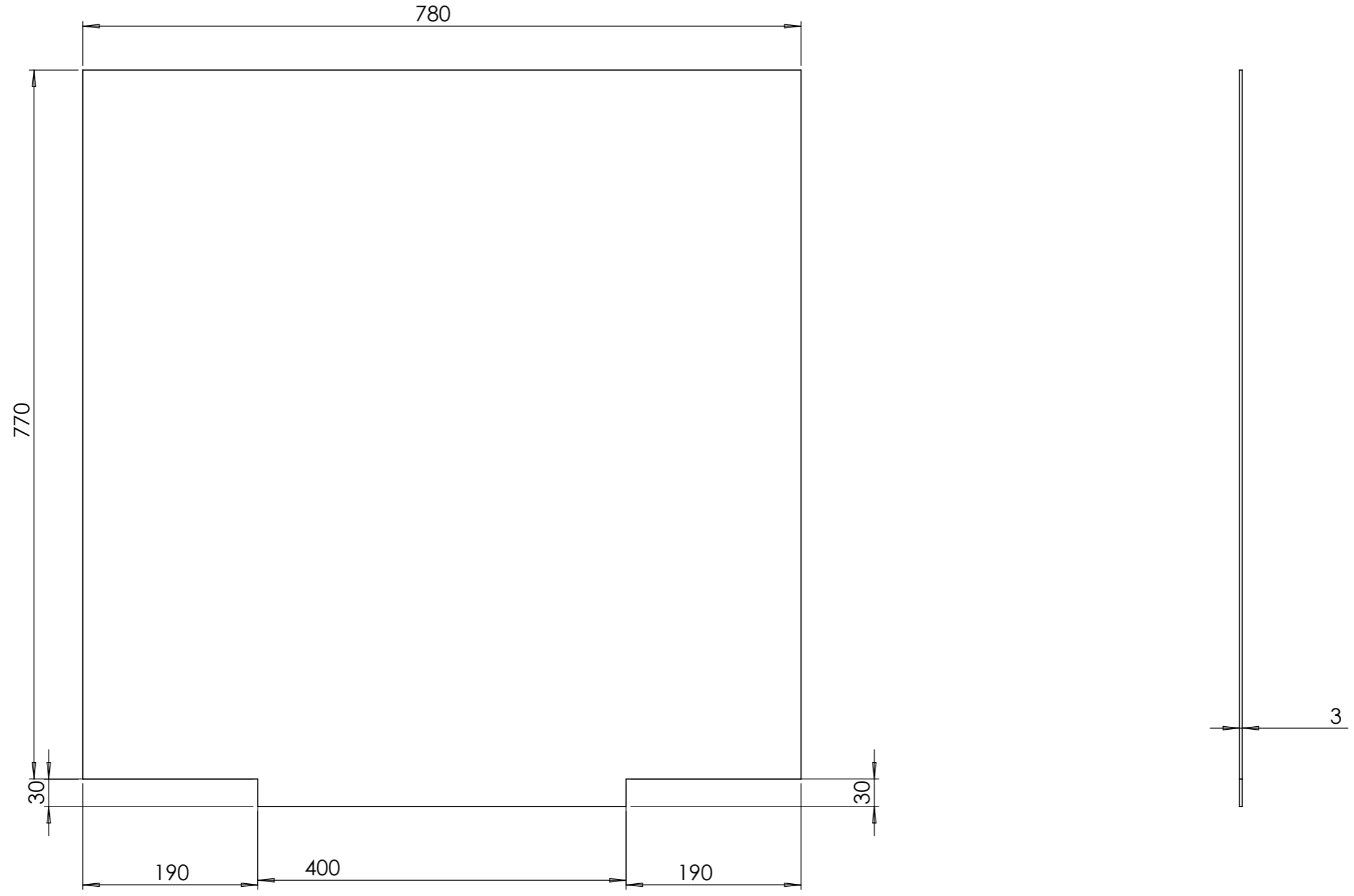

| repère | Désignation | ANGLE1 | ANGLE2 | p | LONGUEUR | Epaisseur de tôlerie | Matériau | Quantité |
|--------|---------------------|--------|--------|---|----------|----------------------|-----------------|----------|
| B2 | B2 épandeur compost | | | | | 0.003 | Acier non allié | 1 |

| | | | | |
|---------|------------------|---------|---------------|-----------------------------|
| Outil | B6 | | | L'atelier paysan |
| Date | 07/12/2022 | Version | page n° 1 / 1 | |
| Feuille | Feuille 1 | | | |

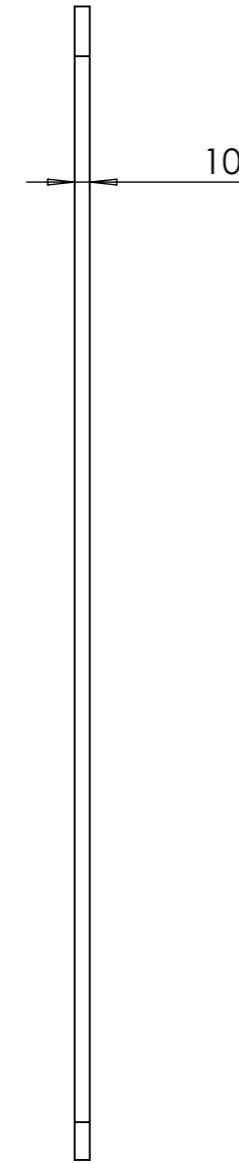
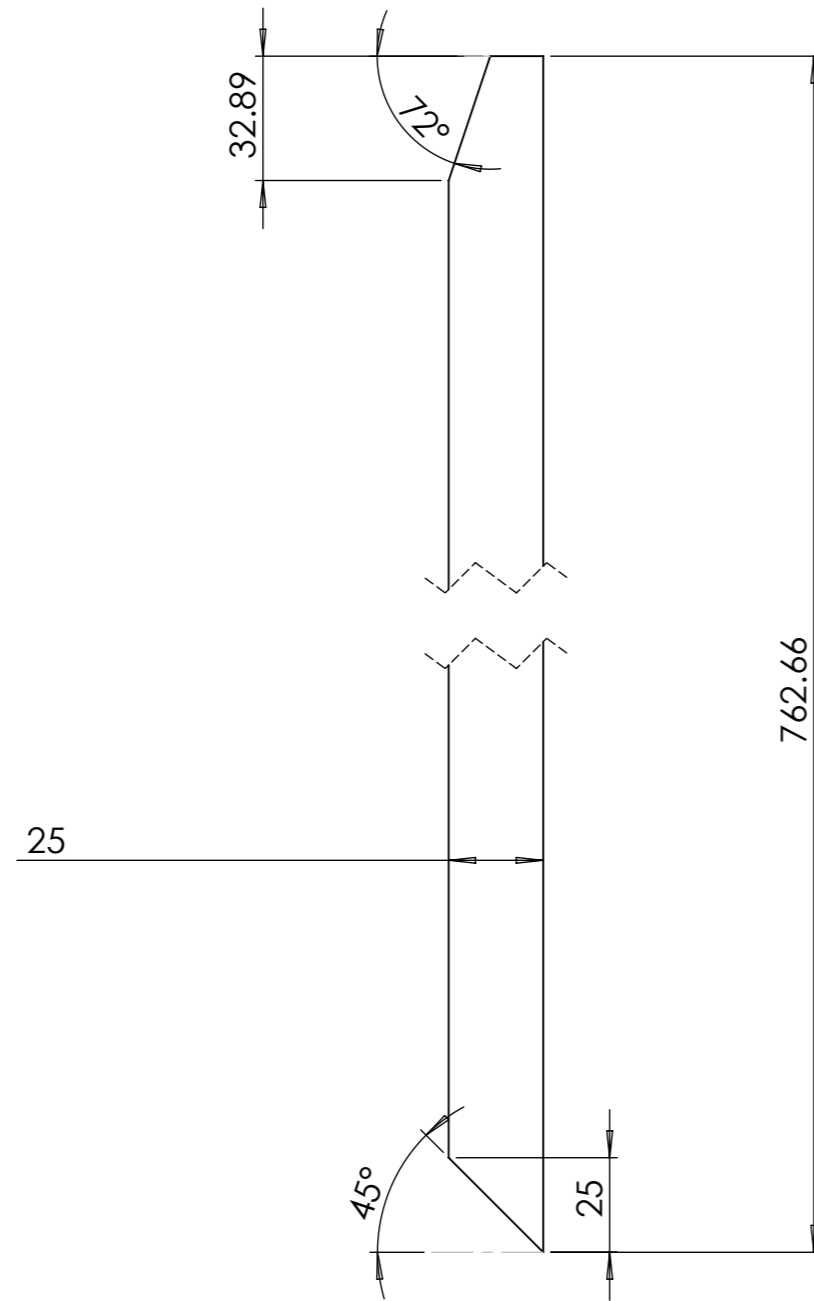

| repère | Désignation | ANGLE1 | ANGLE2 | p | LONGUEUR | Epaisseur de tôlerie | Matériau | Quantité |
|--------|---------------------|--------|--------|---|----------|----------------------|-----------------|----------|
| B6 | B6 épandeur compost | | | | | 0.01 | Acier non allié | 1 |

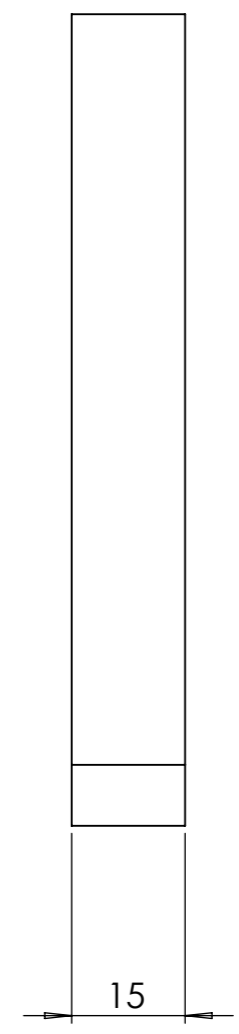
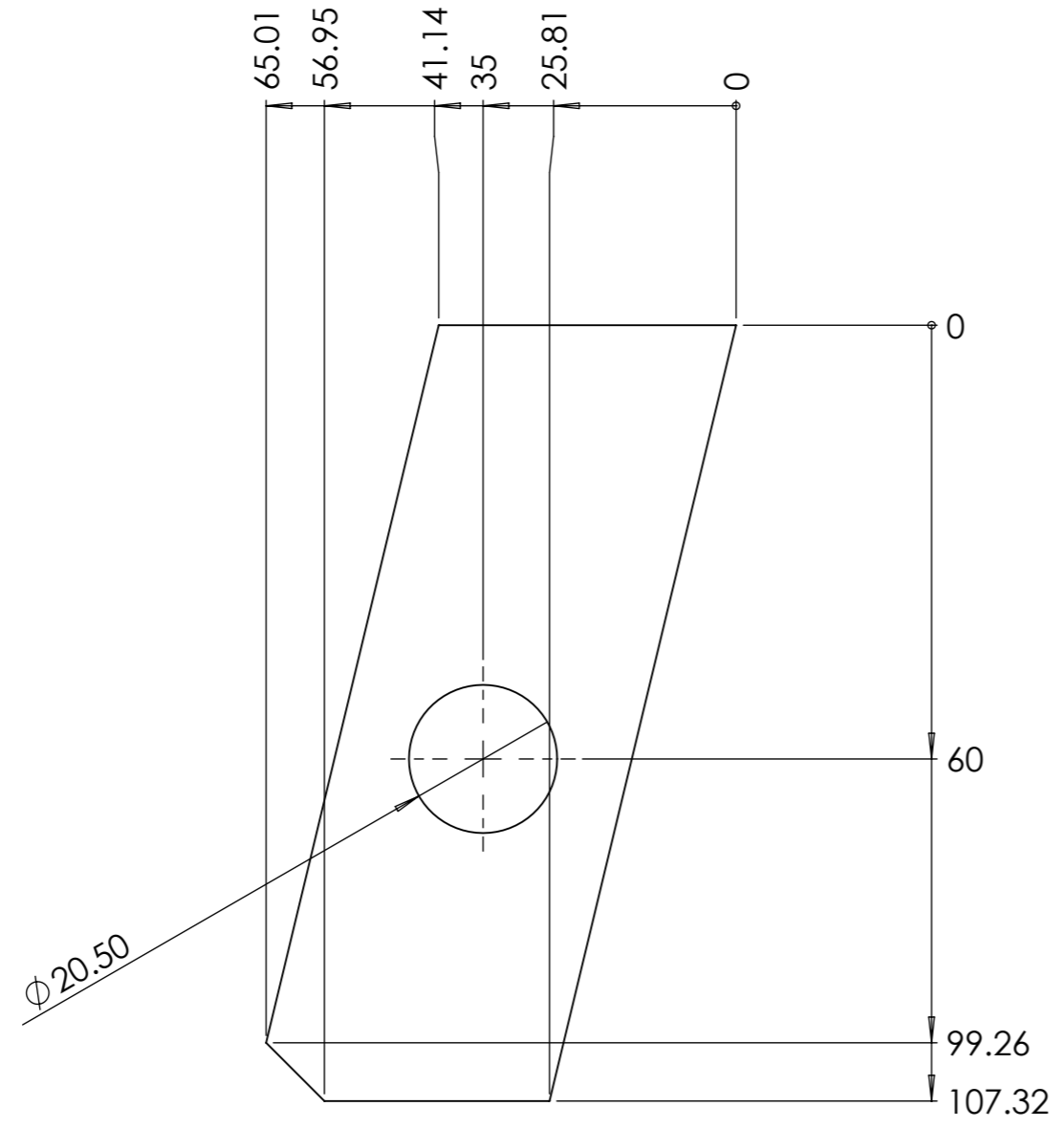

| repère | Désignation | ANGLE1 | ANGLE2 | p | LONGUEUR | Epaisseur de tôle | Matériau | Quantité |
|--------|---------------------|--------|--------|------------------|----------|-------------------|-----------------|----------|
| B8 | B8 épandeur compost | | | 1x $\phi 20,5$; | | 0.015 | Acier non allié | 1 |

| | | | | |
|---------|------------------|---------|---------------|---|
| Outil | B13 | | |  |
| Date | 01/07/2022 | Version | page n° 1 / 1 | |
| Feuille | Feuille 1 | | | |

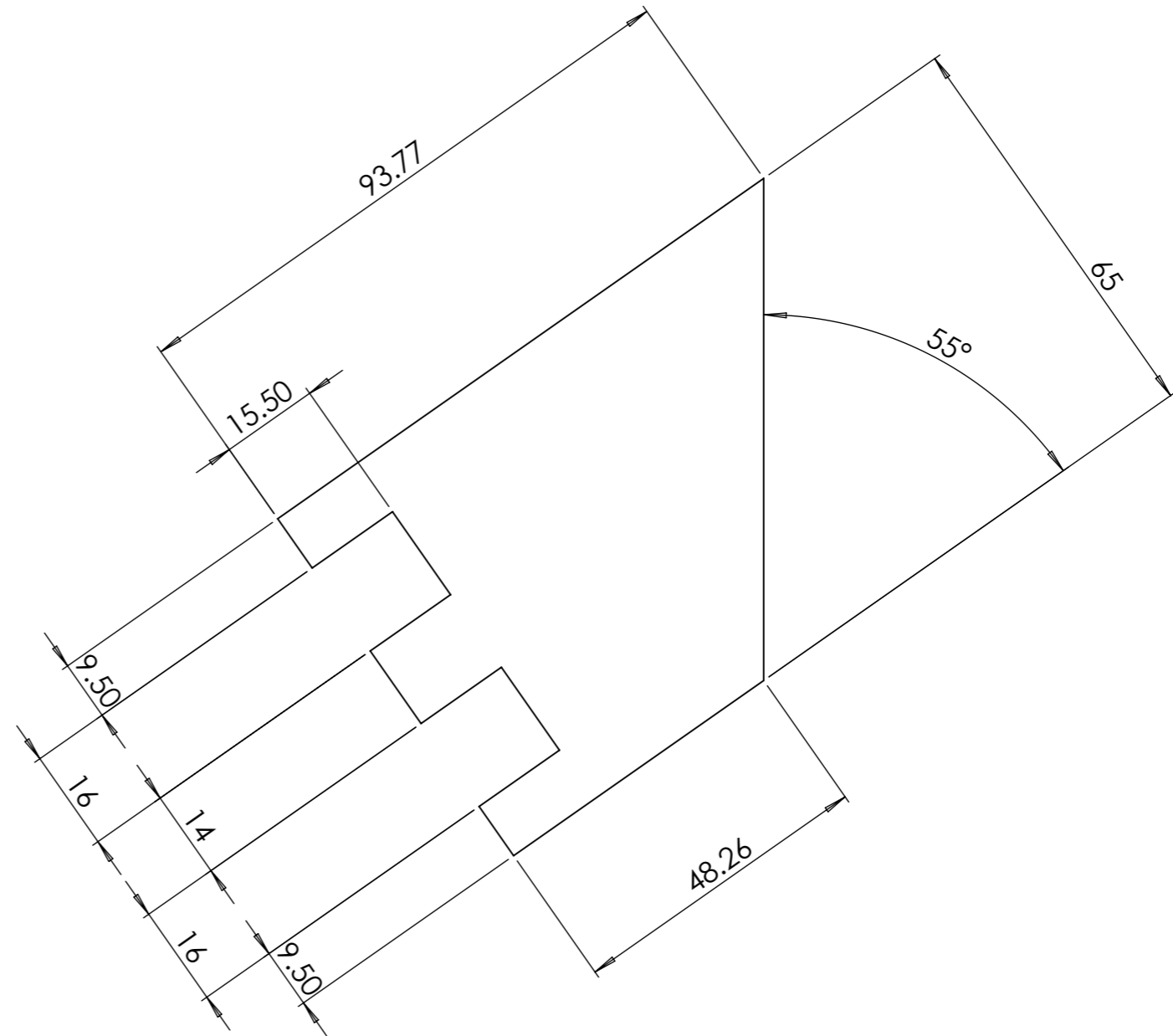
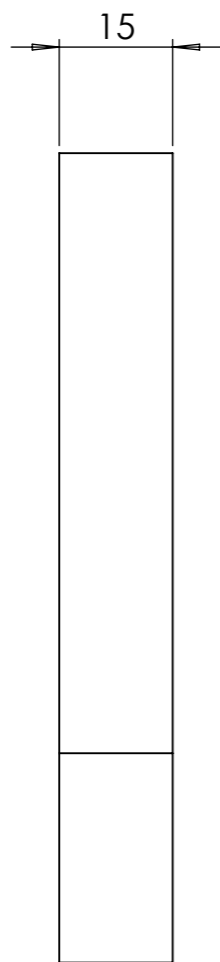

| repère | Désignation | ANGLE1 | ANGLE2 | p | LONGUEUR | Epaisseur de tôlerie | Matériau | Quantité |
|--------|----------------------|--------|--------|---|----------|----------------------|-----------------|----------|
| B13 | B13 épandeur compost | | | | | 0.015 | Acier non allié | 1 |

| | | | | |
|---------|------------------|---------|---------------|---|
| Outil | B15 | | |  |
| Date | 01/07/2022 | Version | page n° 1 / 1 | |
| Feuille | Feuille 1 | | | |

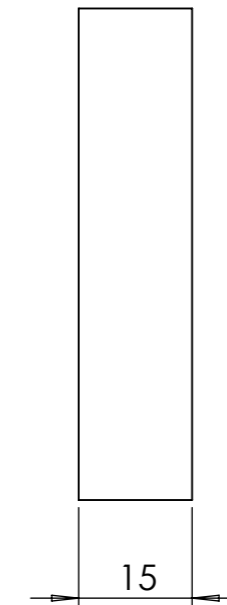
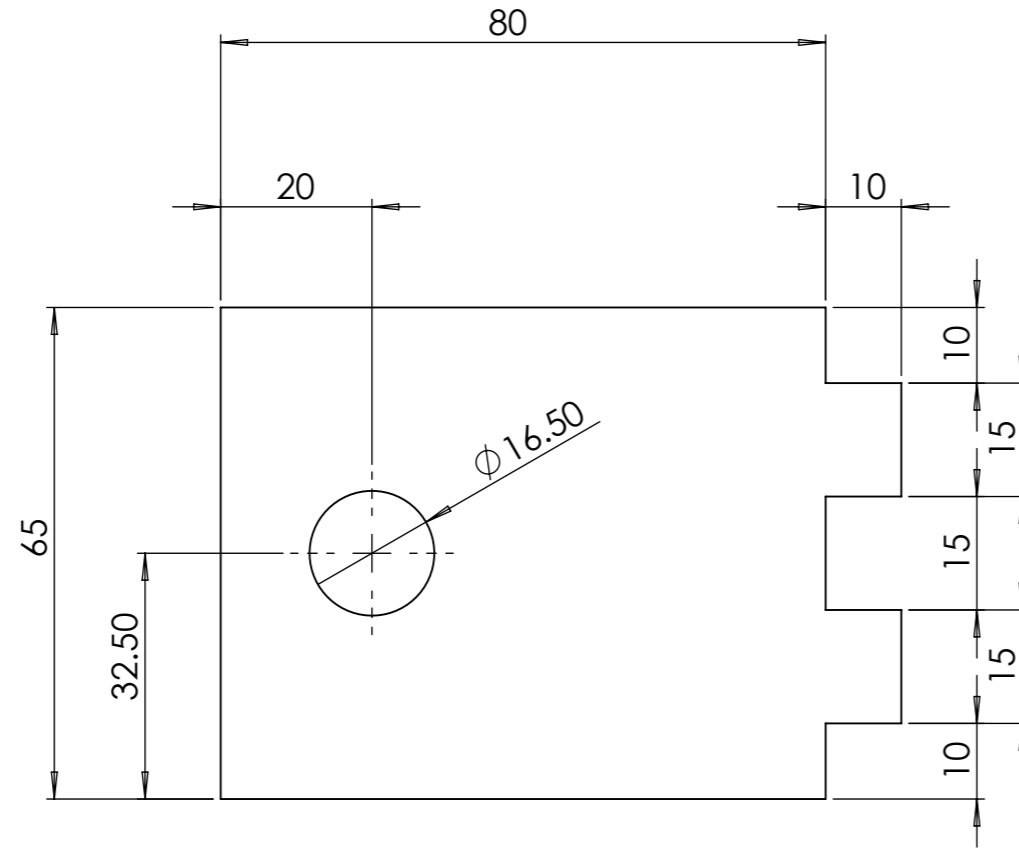

| repère | Désignation | ANGLE1 | ANGLE2 | p | LONGUEUR | Epaisseur de tôlerie | Matériau | Quantité |
|--------|----------------------|--------|--------|------------|----------|----------------------|-----------------|----------|
| B15 | B15 épandeur compost | | | 1x Ø16,5 ; | | 0.015 | Acier non allié | 1 |

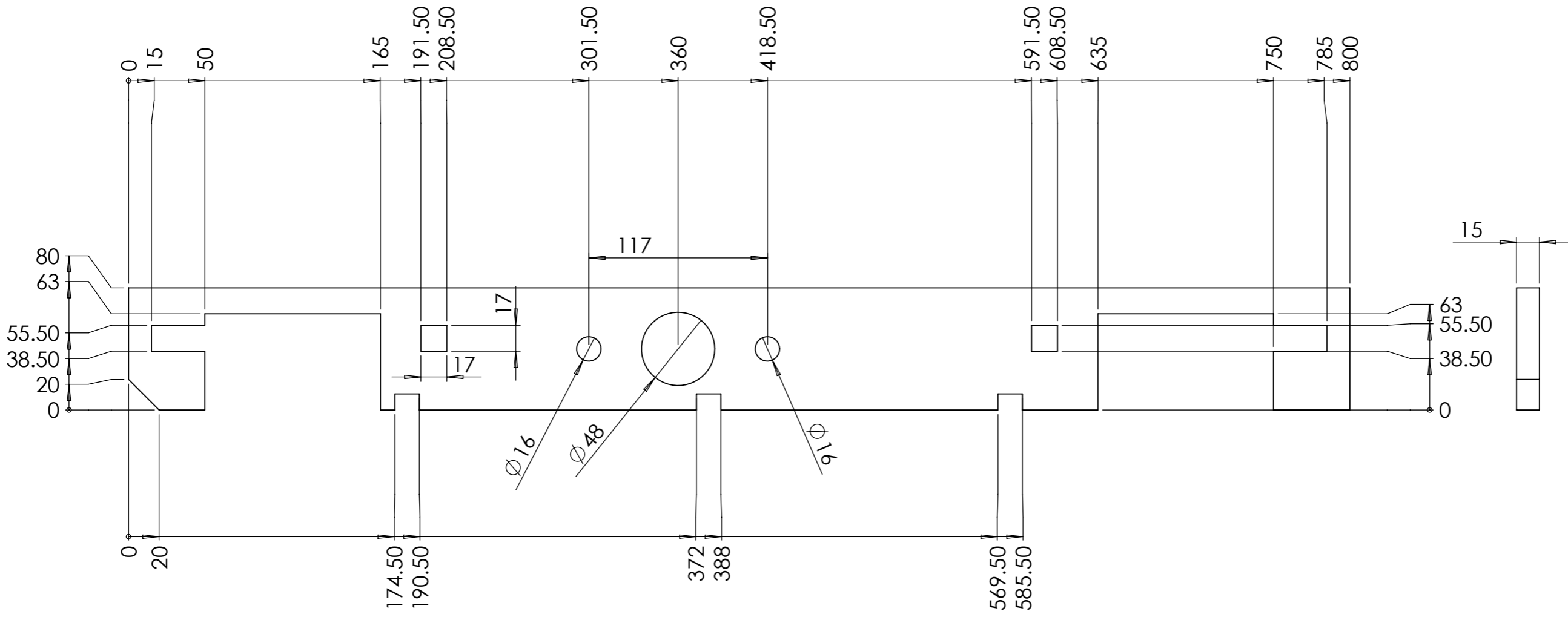

| repère | Désignation | ANGLE1 | ANGLE2 | p | LONGUEUR | Epaisseur de tôlerie | Matériau | Quantité |
|--------|----------------------|--------|--------|---|----------|----------------------|-----------------|----------|
| B16 | B16 épandeur compost | | | | | 0.015 | Acier non allié | 1 |

| | | | | |
|---------|------------------|---------|---------------|---|
| Outil | B19 | | |  |
| Date | 01/07/2022 | Version | page n° 1 / 1 | |
| Feuille | Feuille 1 | | | |

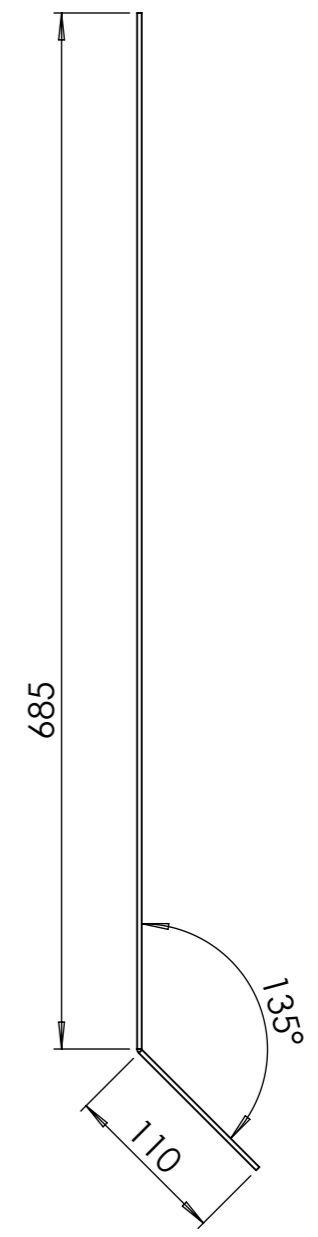
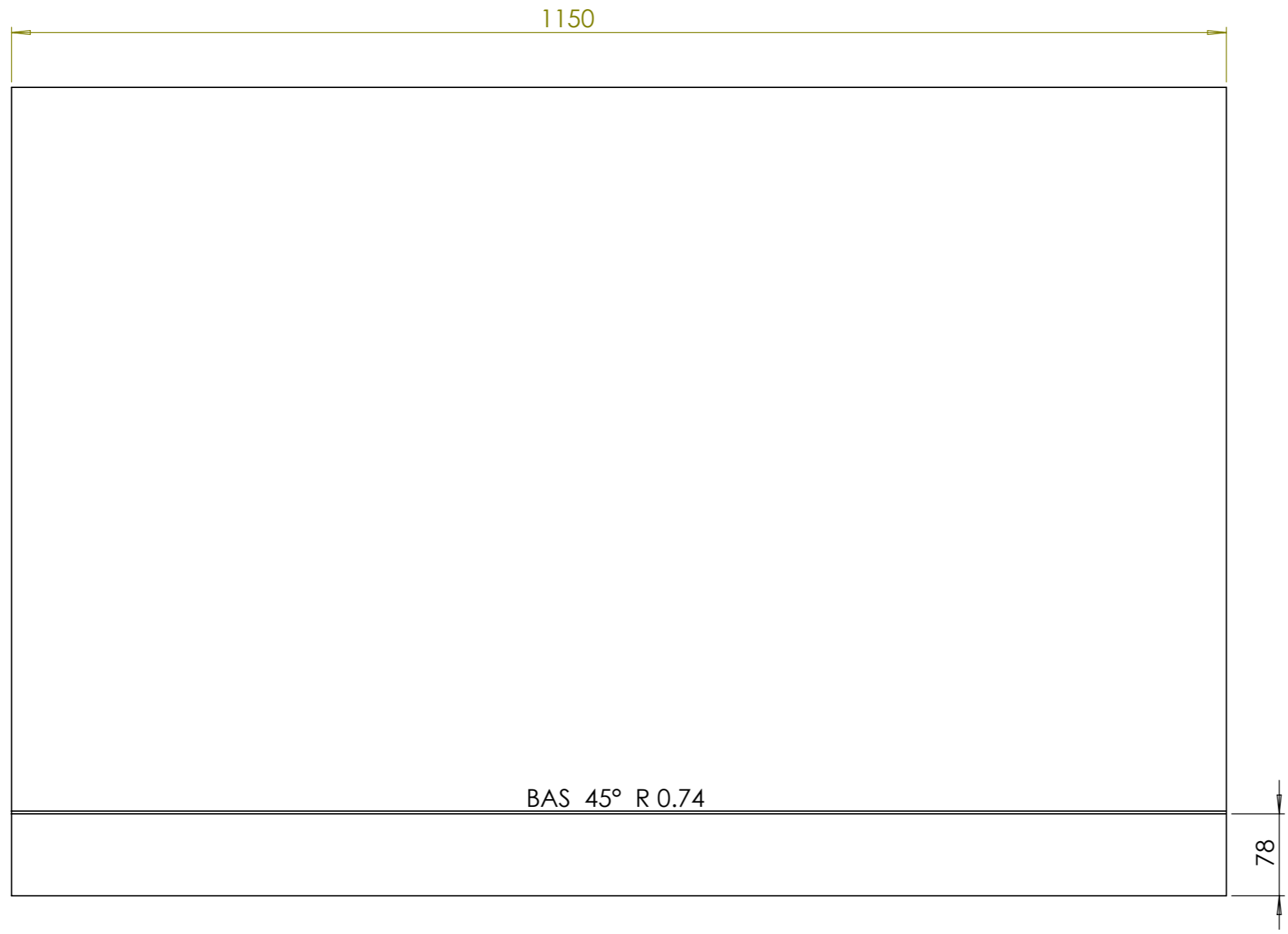

| repère | Désignation | ANGLE1 | ANGLE2 | p | LONGUEUR | Epaisseur de tôle | Matériau | Quantité |
|--------|----------------------|--------|--------|---|----------|-------------------|-----------------|----------|
| B19 | B19 épandeur compost | | | | | 0.003 | Acier non allié | 1 |

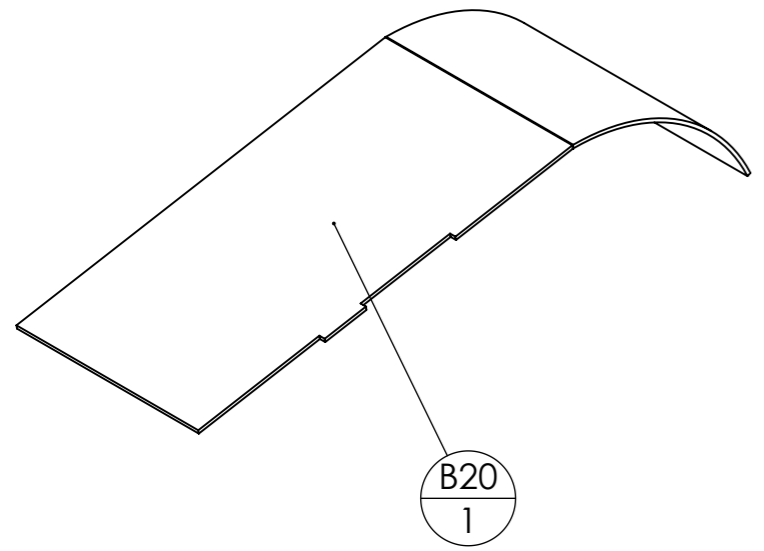

B20
1

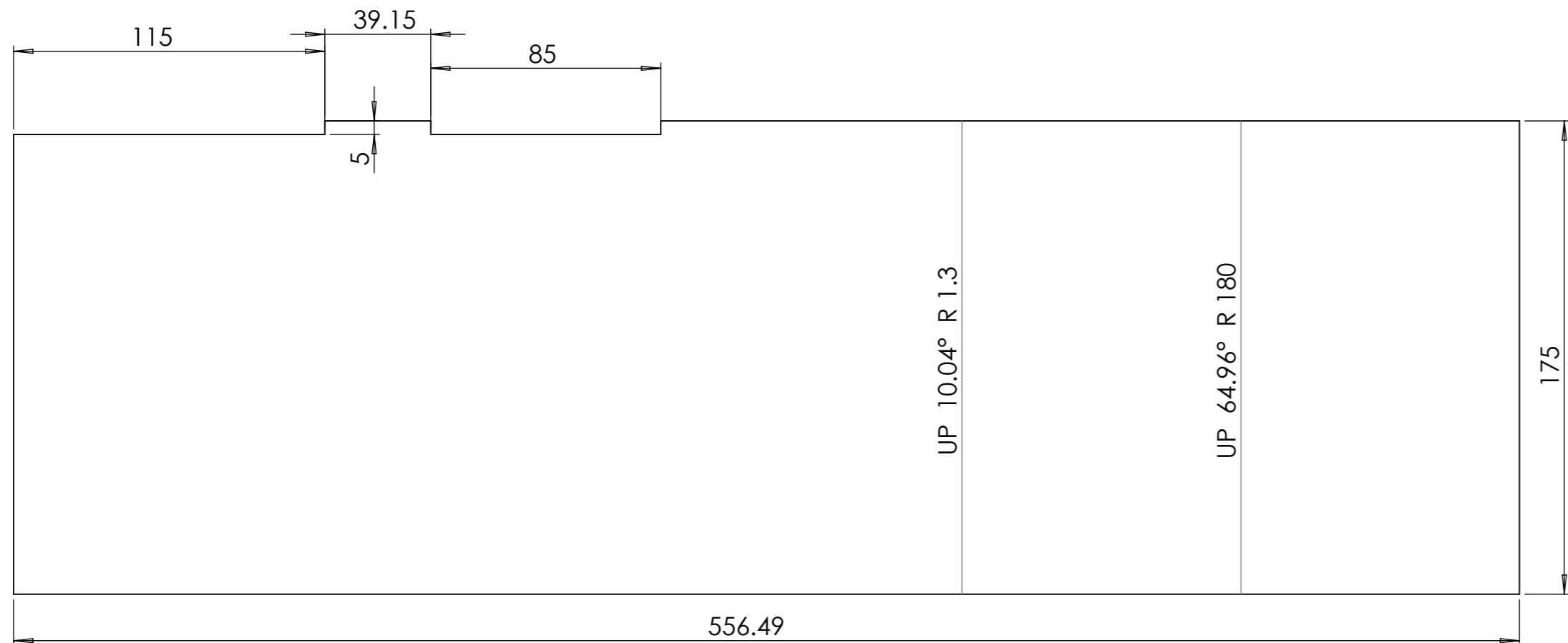
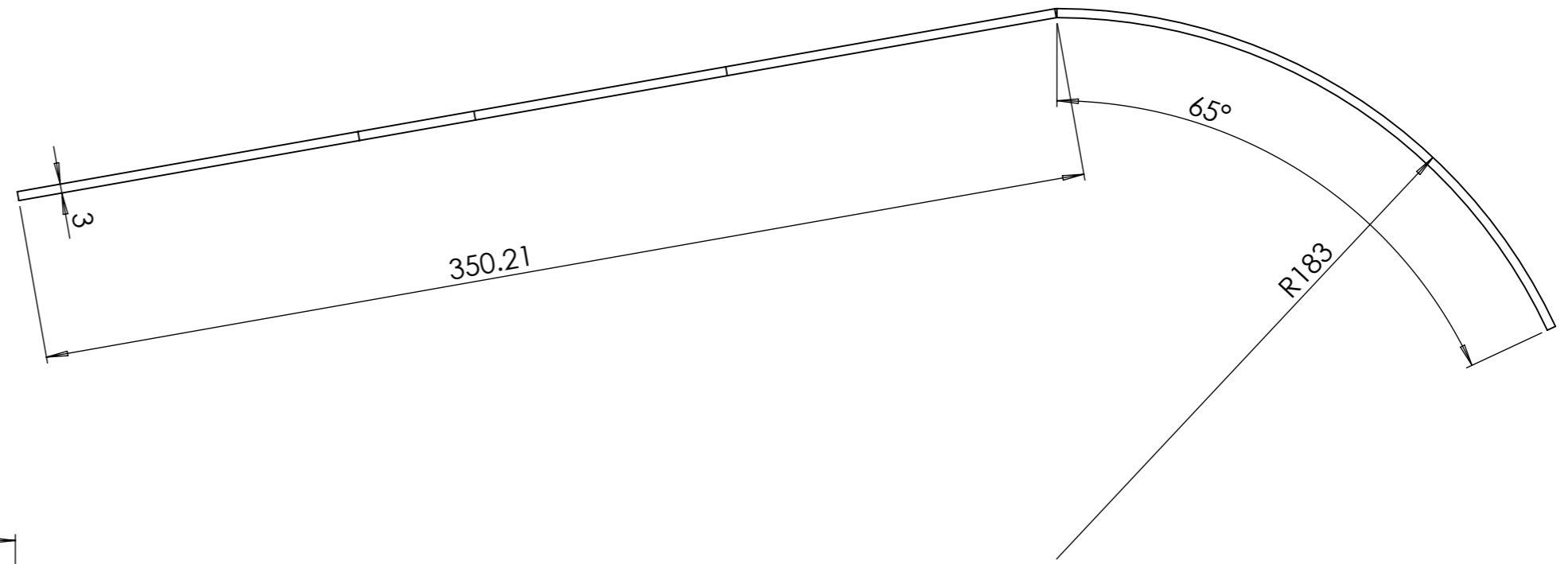

| repère | Désignation | ANGLE1 | ANGLE2 | P | LONGUEUR | Epaisseur de tôlerie | Matériau | Quantité |
|--------|-----------------------------|--------|--------|---|----------|----------------------|-----------------|----------|
| B20 | B20 Carter épandeur compost | | | | SPE | 0.003 | Acier non allié | 1 |

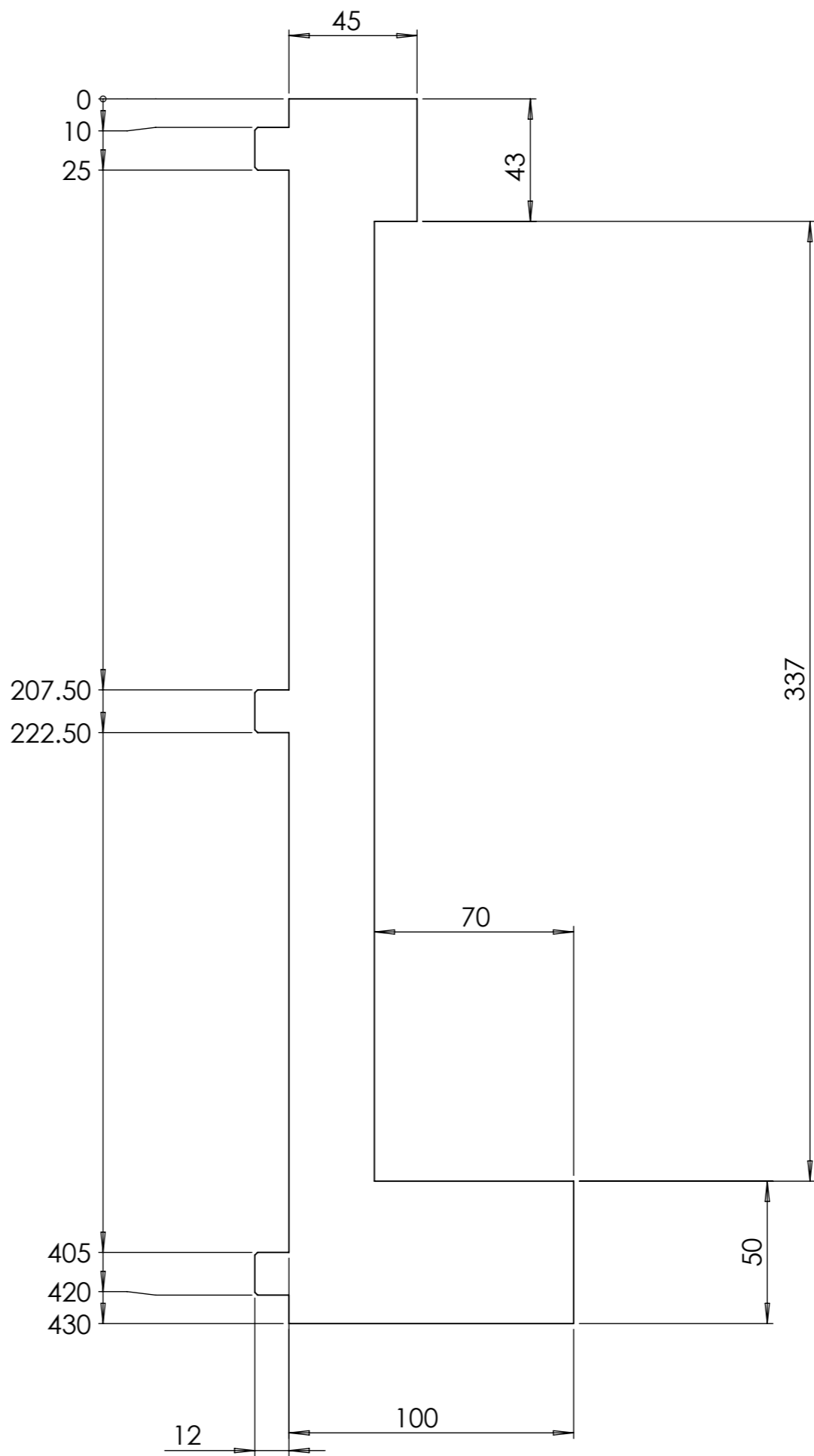
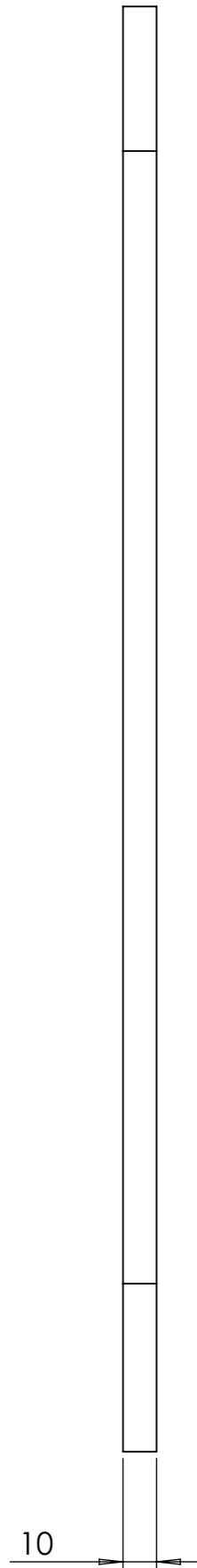

| repère | Désignation | ANGLE1 | ANGLE2 | p | LONGUEUR | Epaisseur de tôlerie | Matériau | Quantité |
|--------|----------------------|--------|--------|---|----------|----------------------|-----------------|----------|
| B24 | B24 épandeur compost | | | | | 0.01 | Acier non allié | 1 |



| repère | Désignation | ANGLE1 | ANGLE2 | p | LONGUEUR | Epaisseur de tôlerie | Matériau | Quantité |
|--------|-------------|--------|--------|---|----------|----------------------|-----------------|----------|
| B29 | | | | | | 3 | Acier non allié | 1 |

| | | | | |
|---------|------------|---------|---------------|---|
| Outil | BA1 | | |  |
| Date | 01/07/2022 | Version | page n° 1 / 1 | |
| Feuille | Feuille 1 | | | |

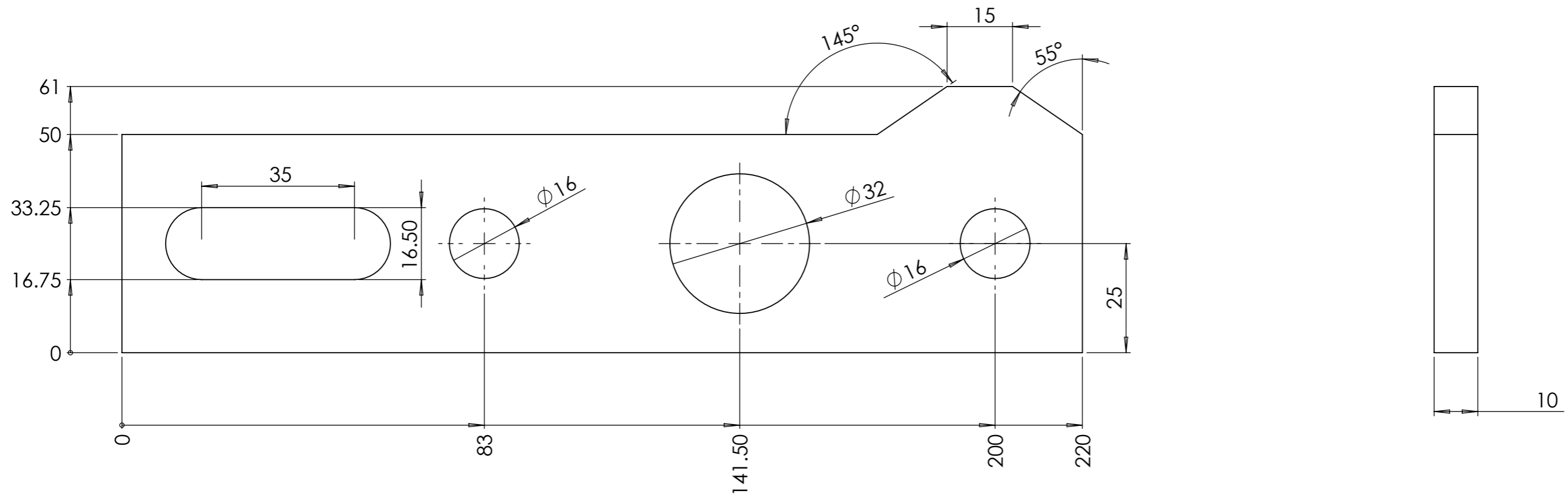

| repère | Désignation | ANGLE1 | ANGLE2 | p | LONGUEUR | Quantité |
|--------|----------------------|--------|--------|------------------------|----------|----------|
| BA1 | BA1 épandeur compost | | | 2x Ø16,5 ; 1x Ø32 ; | | 1 |

| | | | | |
|---------|------------|---------|---------------|---|
| Outil | BB3 | | |  |
| Date | 28/03/2023 | Version | page n° 1 / 1 | |
| Feuille | Feuille 1 | | | |

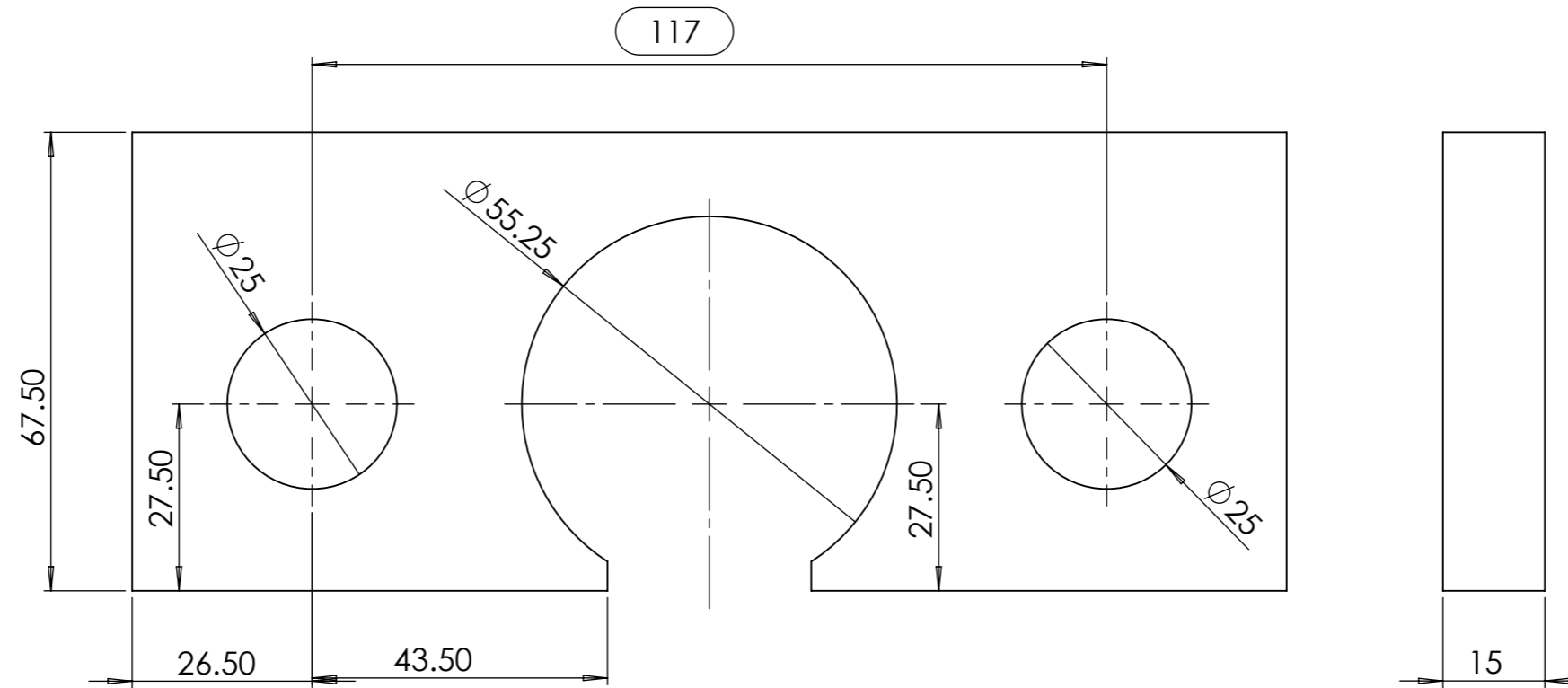

| repère | Désignation | ANGLE1 | ANGLE2 | p | LONGUEUR | Quantité |
|--------|----------------------|--------|--------|----------|----------|----------|
| BB3 | BB3 épandeur compost | | | 2x Ø25 ; | | 1 |

| | | | | |
|---------|------------------|---------|--|-----------------------------|
| Outil | D2 | | | L'atelier paysan |
| Date | 28/03/2023 | Version | | |
| Feuille | Feuille 1 | | | |

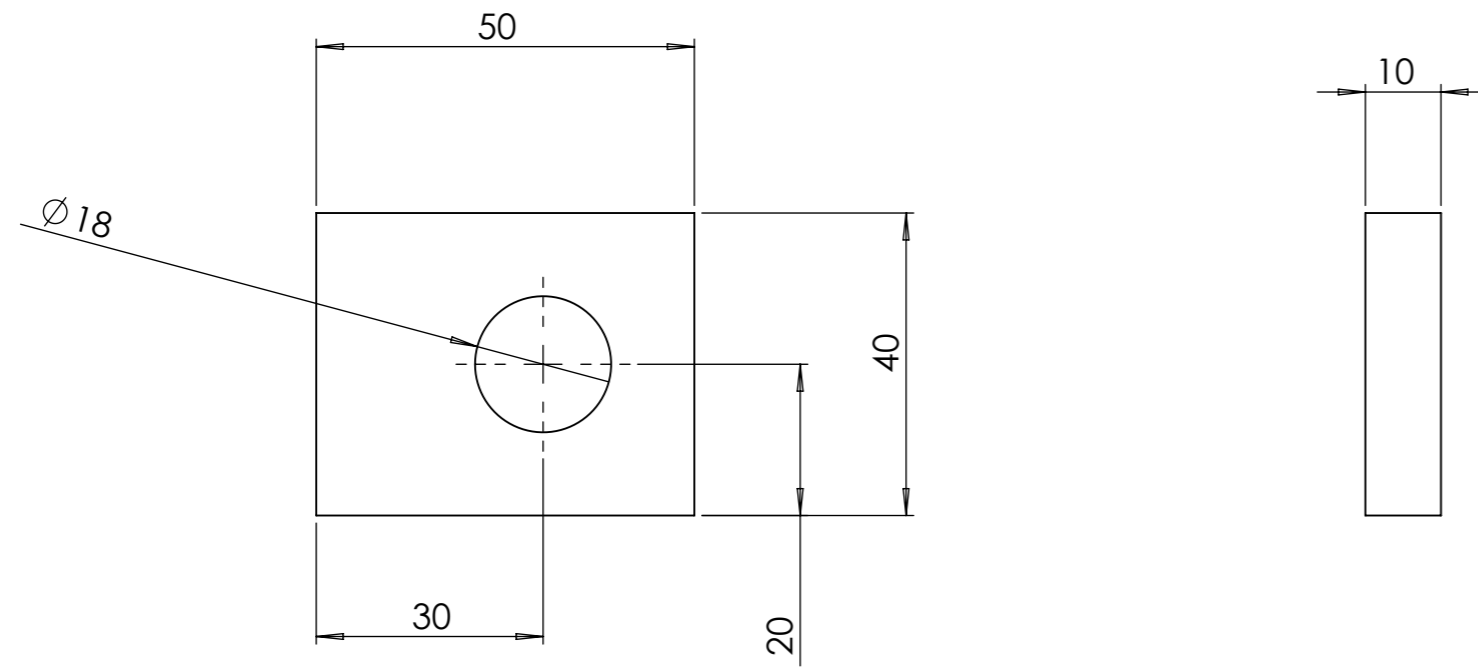

| repère | Désignation | ANGLE1 | ANGLE2 | p | LONGUEUR | Epaisseur de tôlerie | Matériau | Quantité |
|--------|---------------------|--------|--------|---|----------|----------------------|-----------------|----------|
| D2 | D2 épandeur compost | | | | | 0.01 | Acier non allié | 1 |

| | | | | |
|---------|--------------|---------|-----|---|
| Outil | Gabarit roue | | |  |
| Date | 18/01/2022 | Version | 1.2 | |
| Feuille | Gabarit | | | |

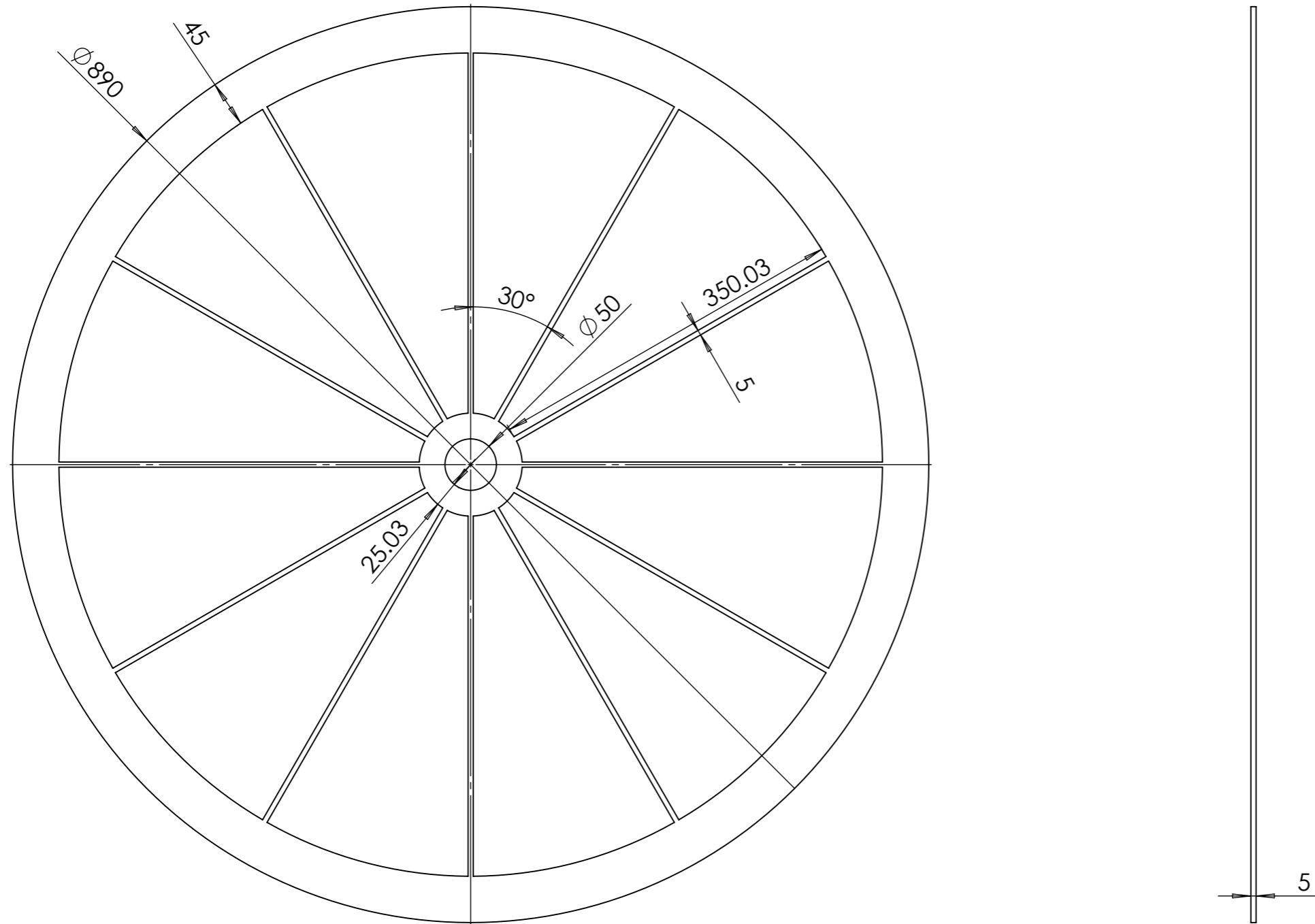

Gabarit à fabriquer ou à commander en laser, permet de placer les rayons de la roue.

| | | | | |
|---------|------------|---------|---------------|---|
| Outil | R2 | | |  |
| Date | 18/01/2022 | Version | page n° 1 / 1 | |
| Feuille | Feuille 1 | | | |

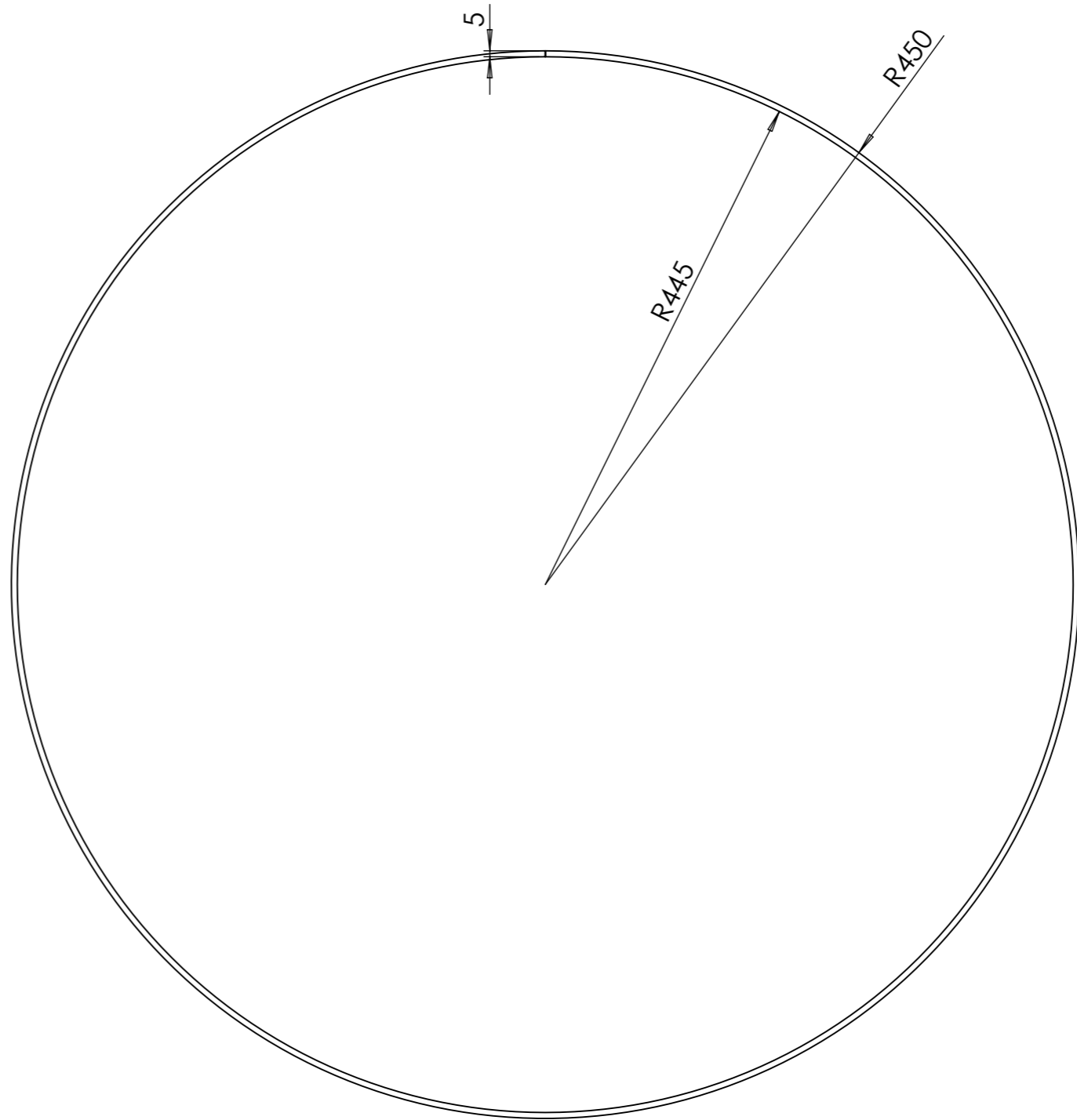
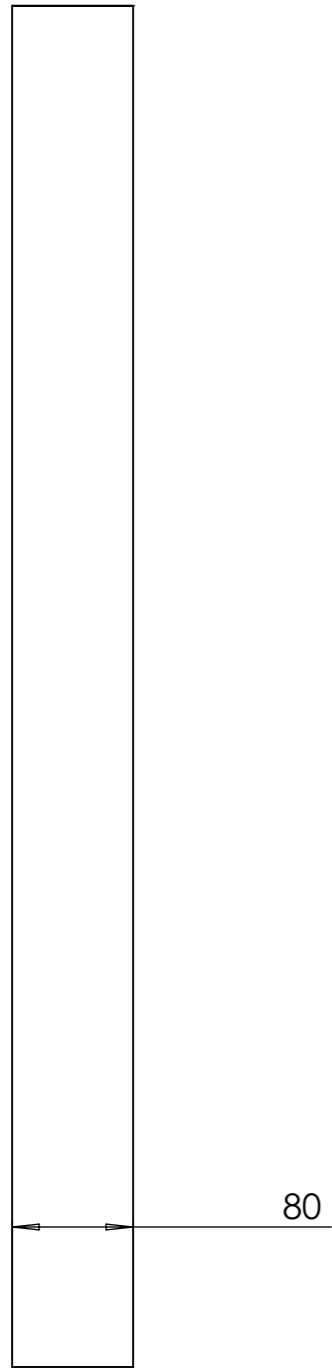

| repère | Désignation | ANGLE1 | ANGLE2 | p | LONGUEUR | Epaisseur de tôlerie | Matériau | Quantité |
|--------|---------------------|--------|--------|---|----------|----------------------|-----------------|----------|
| R2 | R2 épandeur compost | | | | | 0.005 | Acier non allié | 1 |

| | | | | |
|---------|------------------|---------|---------------|---|
| Outil | R3 | | |  |
| Date | 18/01/2022 | Version | page n° 1 / 1 | |
| Feuille | Feuille 1 | | | |

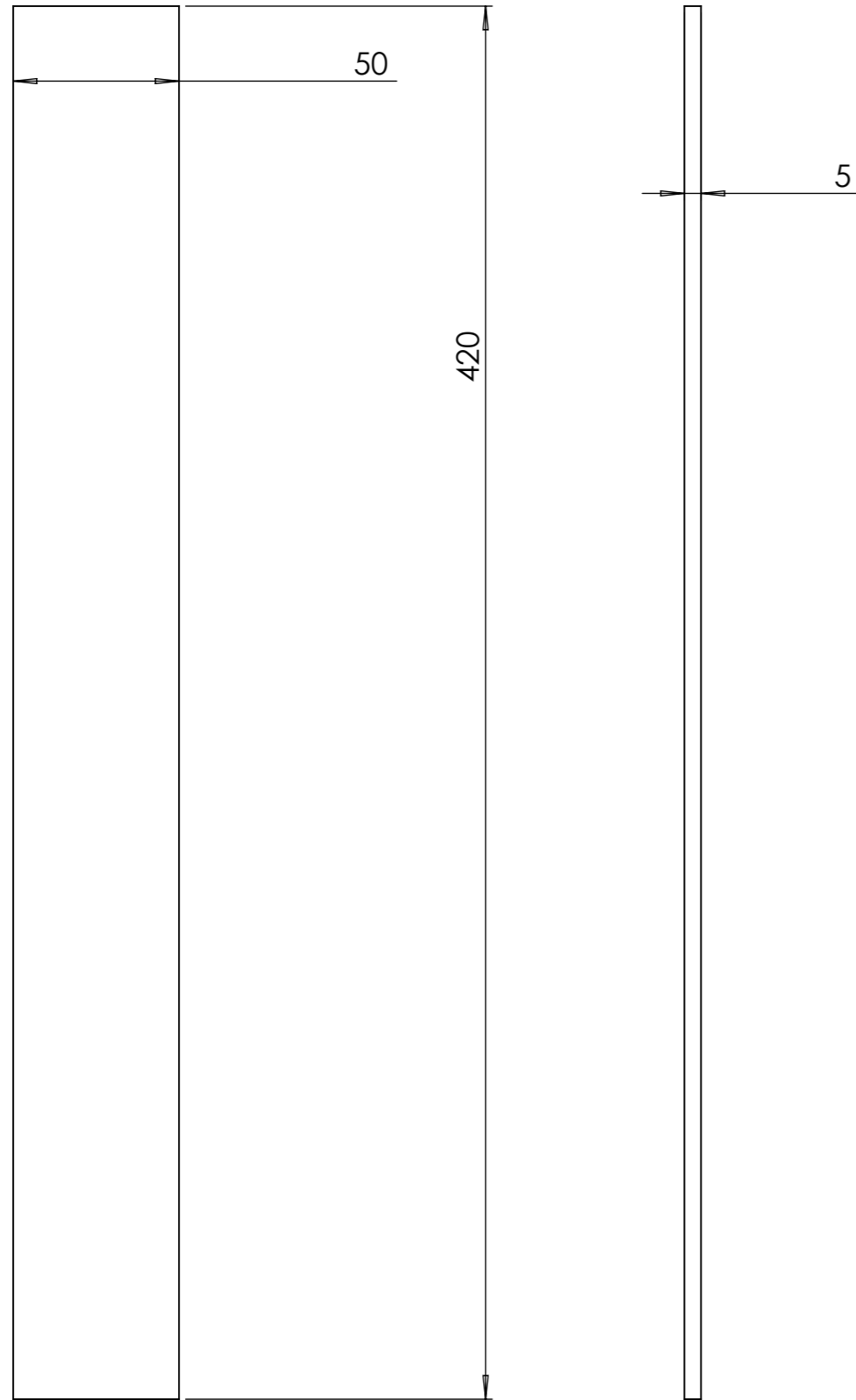

| repère | Désignation | ANGLE1 | ANGLE2 | p | LONGUEUR | Epaisseur de tôlerie | Matériau | Quantité |
|--------|---------------------|--------|--------|---|----------|----------------------|-----------------|----------|
| R3 | R3 épandeur compost | | | | | 0.005 | Acier non allié | 1 |

| | | | | | |
|---------|------------|---------|-----|---|---------------|
| Outil | R5 | | |  | |
| Date | 01/07/2022 | Version | 1.3 | | page n° 1 / 1 |
| Feuille | R5 | | | | |

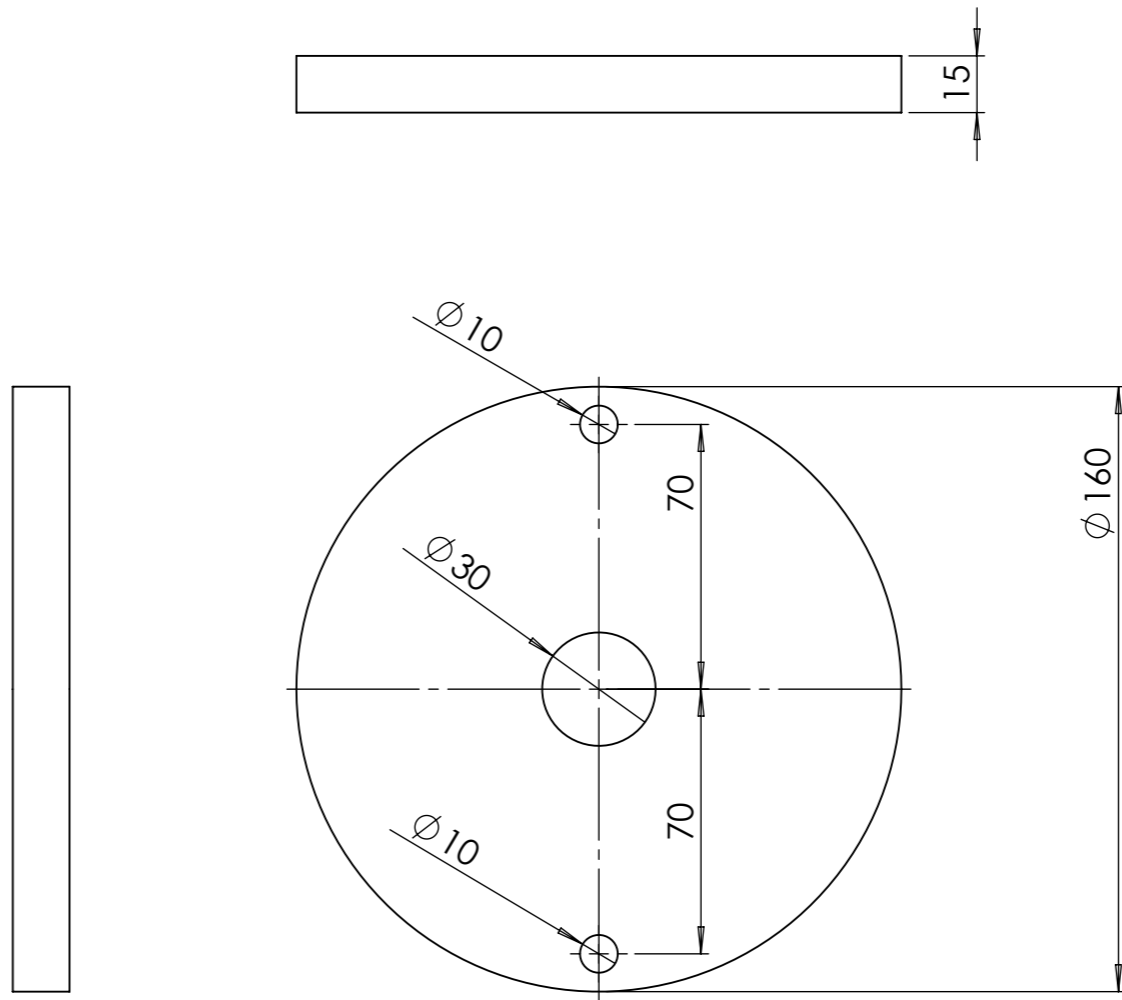
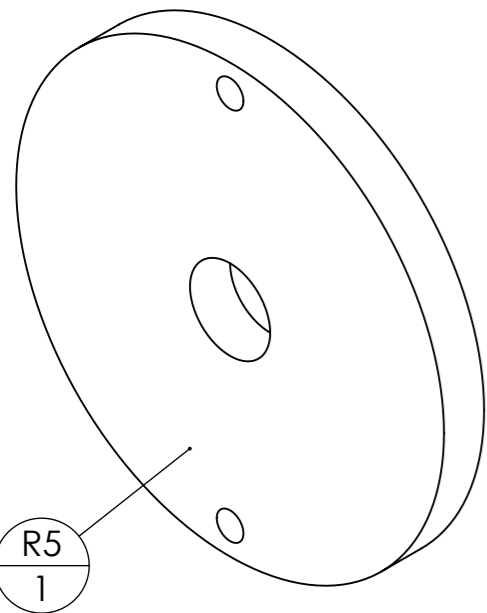

R5
1

| repère | Désignation | ANGLE1 | ANGLE2 | p | LONGUEUR | Epaisseur de tôle | Matériau | Quantité |
|--------|------------------------------|--------|--------|----------------------|----------|-------------------|-----------------|----------|
| R5 | R5 coupelle épandeur compost | | | 1x Ø30 ; 2x Ø10 ; | | | Acier non allié | 1 |

| | | | | |
|---------|------------------|---------|---------------|---|
| Outil | R6 | | |  |
| Date | 05/12/2022 | Version | page n° 1 / 1 | |
| Feuille | Feuille 1 | | | |

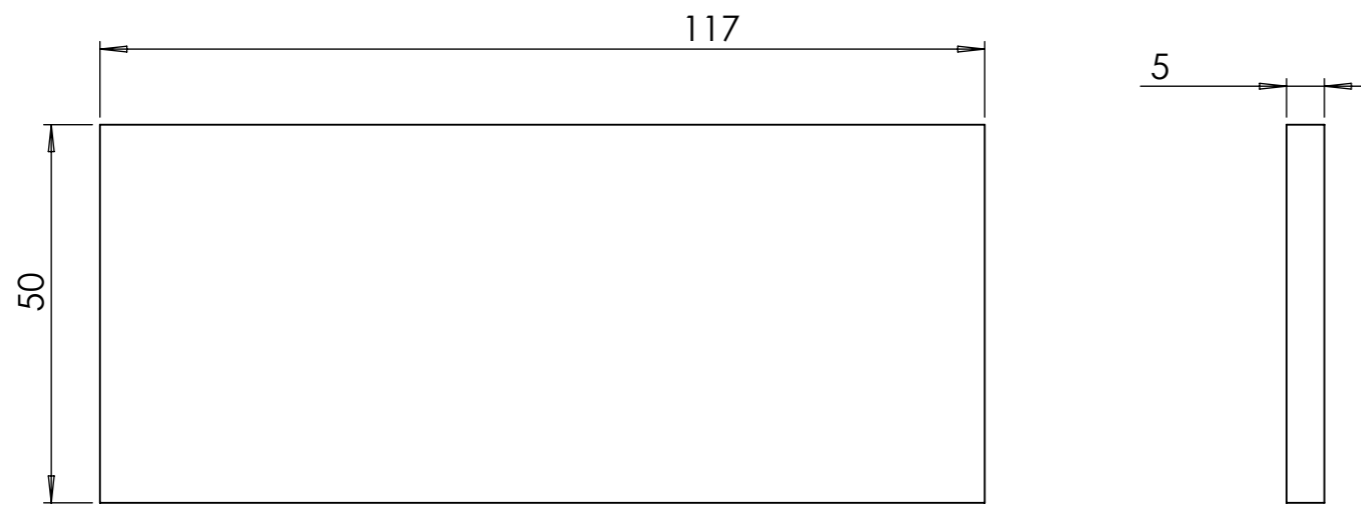

| repère | Désignation | ANGLE1 | ANGLE2 | p | LONGUEUR | Epaisseur de tôlerie | Matériau | Quantité |
|--------|---------------------|--------|--------|---|----------|----------------------|-----------------|----------|
| R6 | R6 épandeur compost | | | | | 0.005 | Acier non allié | 1 |

| | | | | |
|---------|------------|---------|--|---|
| Outil | AB2 | | |  |
| Date | 12/01/2023 | Version | | |
| Feuille | Feuille 1 | | | |



∅ 7
M8x1.25

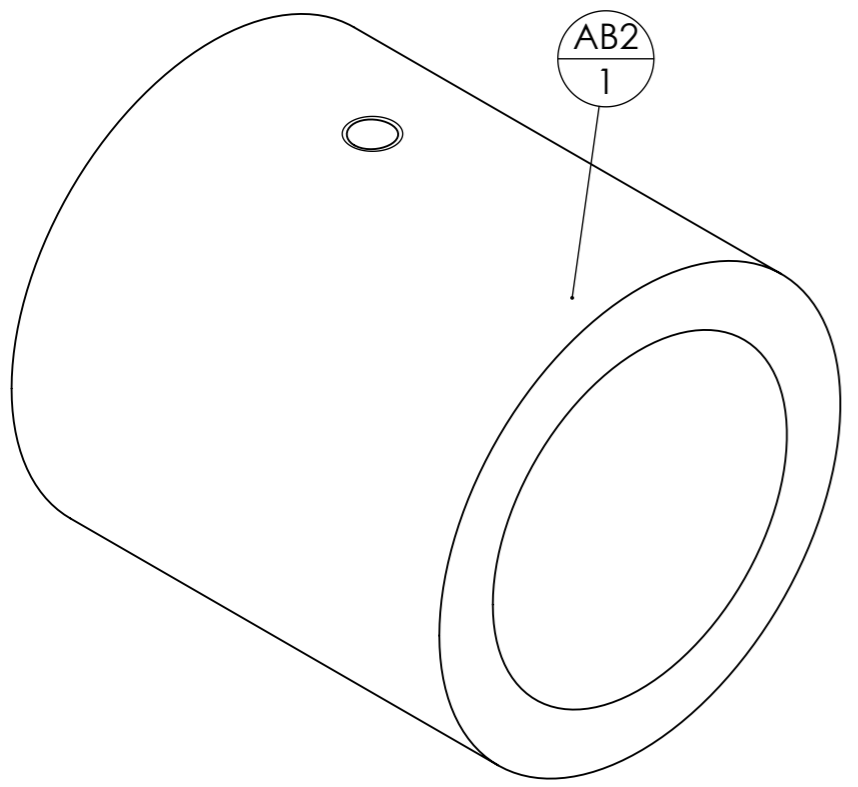
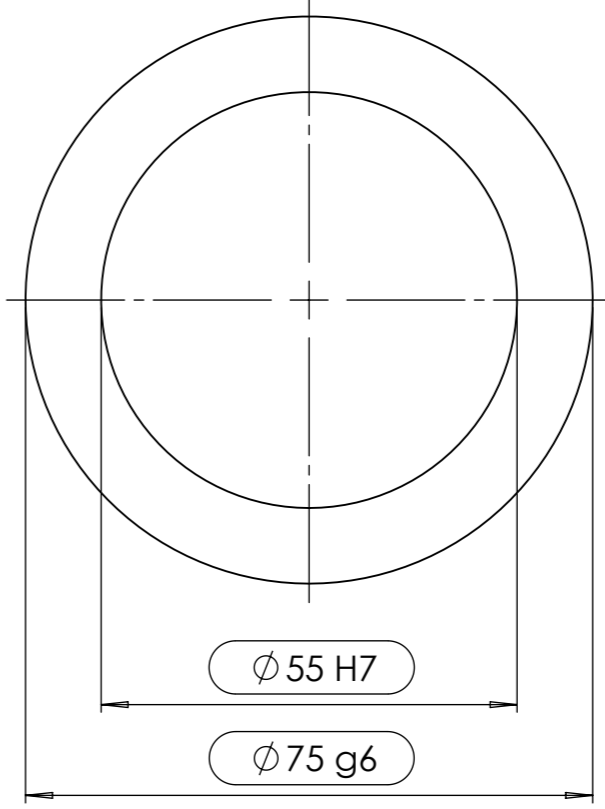
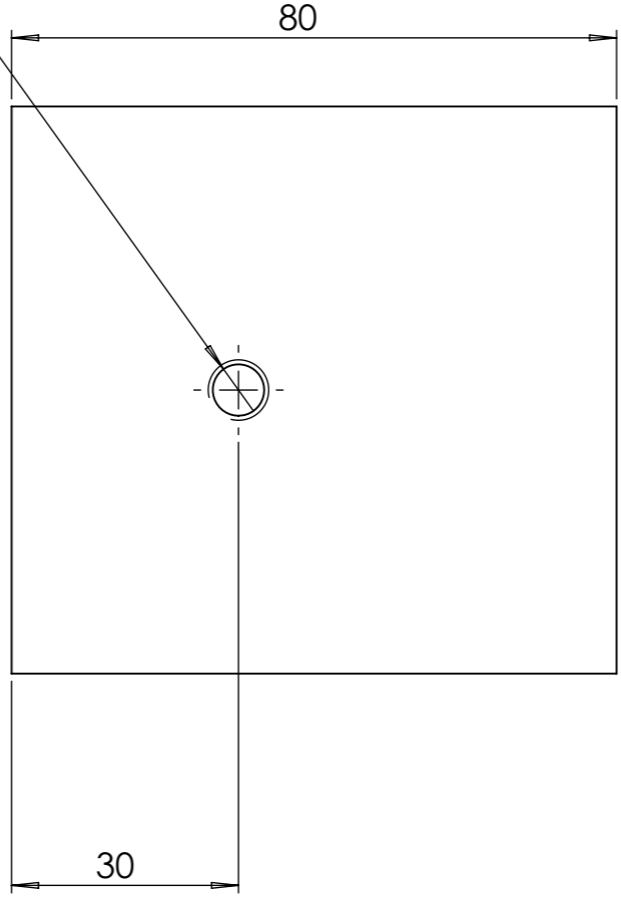

| repère | Désignation | ANGLE1 | ANGLE2 | P | LONGUEUR | Epaisseur de tôlerie | Matériau | Quantité |
|--------|--|--------|--------|---|----------|----------------------|----------|----------|
| AB2 | Bague tournée ∅int 55 - ∅ext 75 - L 80 | | | | SPE | | | 1 |

| | | | | |
|---------|------------|---------|---------------|---|
| Outil | BB1 | | |  |
| Date | 12/01/2023 | Version | page n° 1 / 1 | |
| Feuille | BB1 | | | |

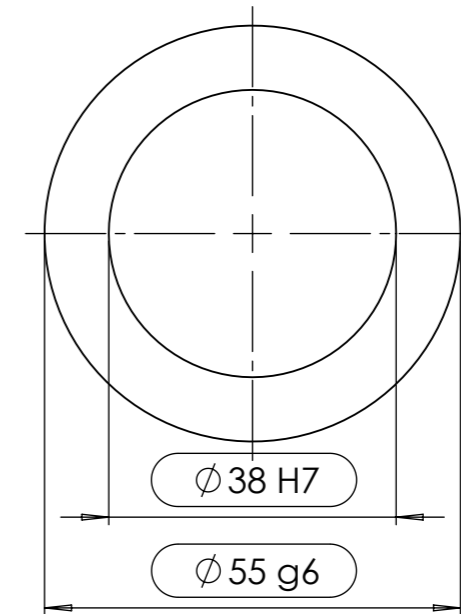
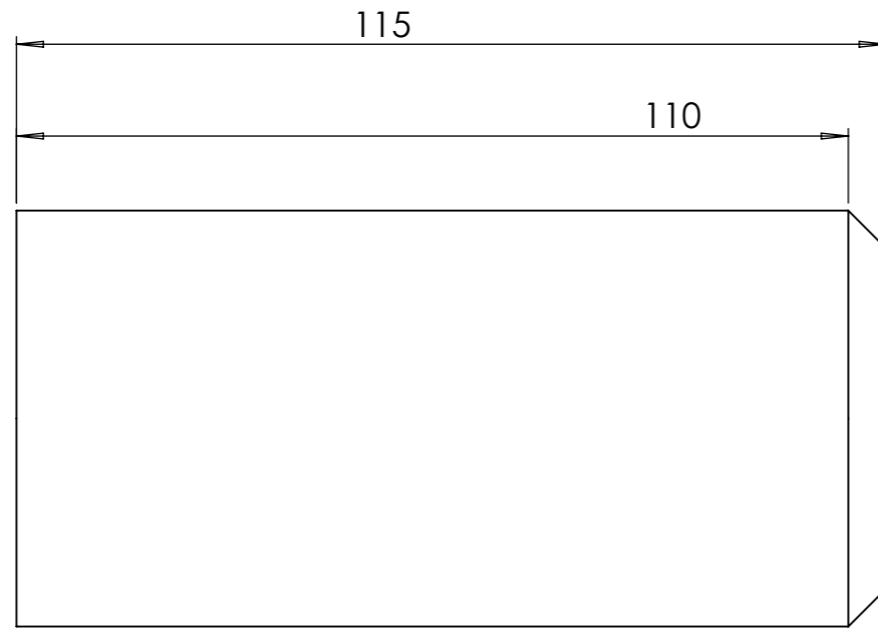

| repère | Désignation | ANGLE1 | ANGLE2 | p | LONGUEUR | Quantité |
|--------|---|--------|--------|-------------------|----------|----------|
| BB1 | Bague tournée $\text{Øint}38 - \text{Øext}55 - \text{L}115$ | | | 1x $\text{Ø}38$; | | 1 |

| | | | | |
|---------|------------------|---------|--|---|
| Outil | R1 | | |  |
| Date | 12/01/2023 | Version | | |
| Feuille | Feuille 1 | | | |

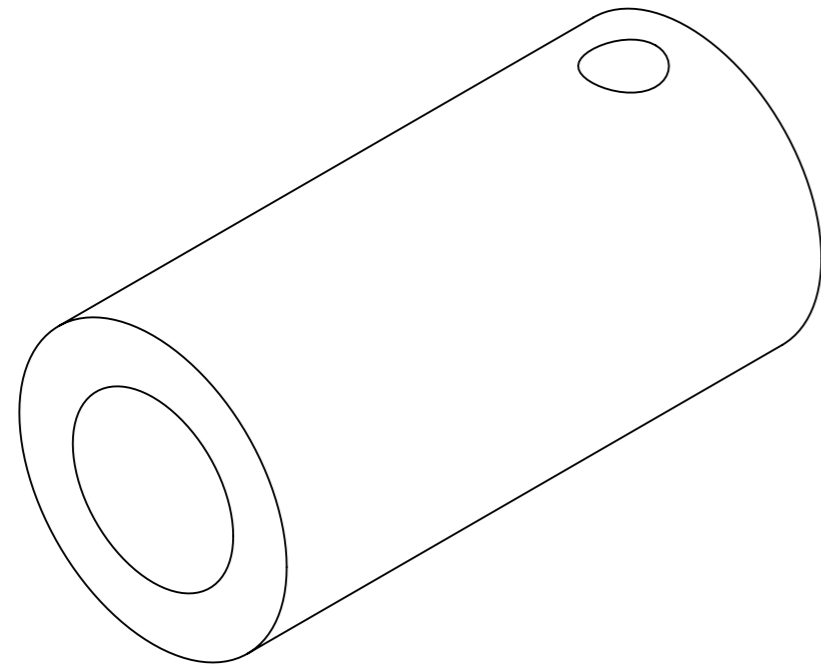
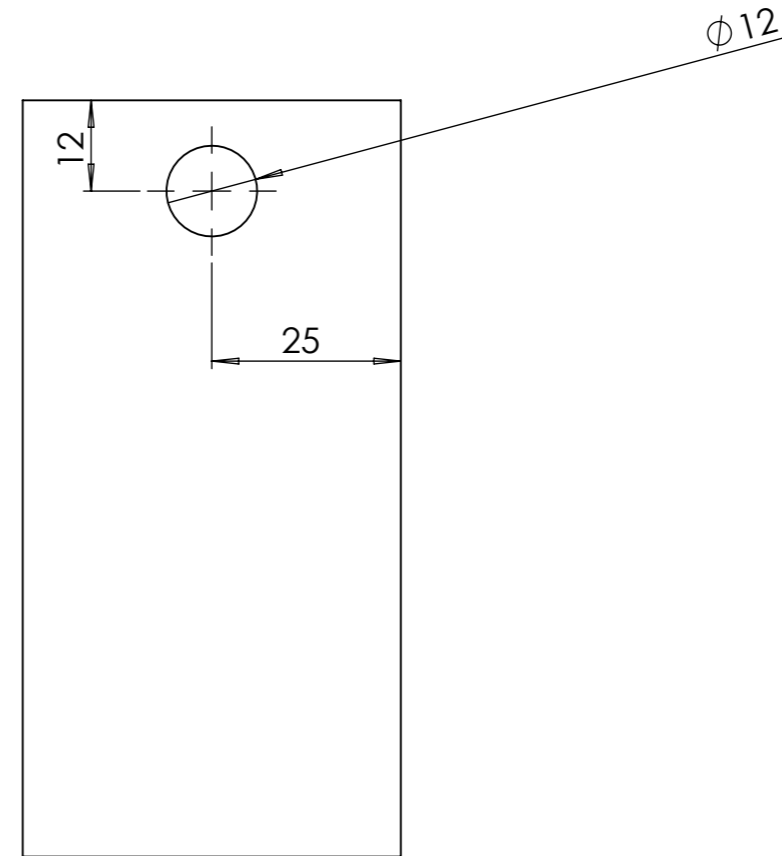
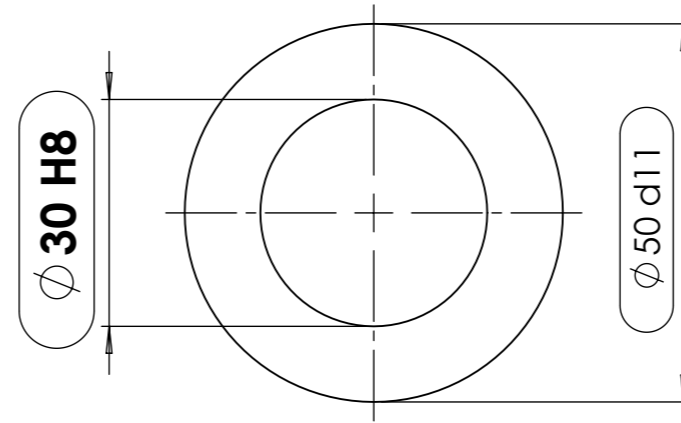

| repère | Désignation | ANGLE1 | ANGLE2 | p | LONGUEUR | Epaisseur de tôlerie | Matériau | Quantité |
|--------|---------------------|--------|--------|----------------------|----------|----------------------|----------|----------|
| R1 | R1 épandeur compost | | | 1x Ø30 ; 2x Ø12 ; | | | | 1 |

| | | | | |
|---------|------------|---------|--|---|
| Outil | R2 | | |  |
| Date | 19/10/2021 | Version | | |
| Feuille | Feuille 1 | | | |

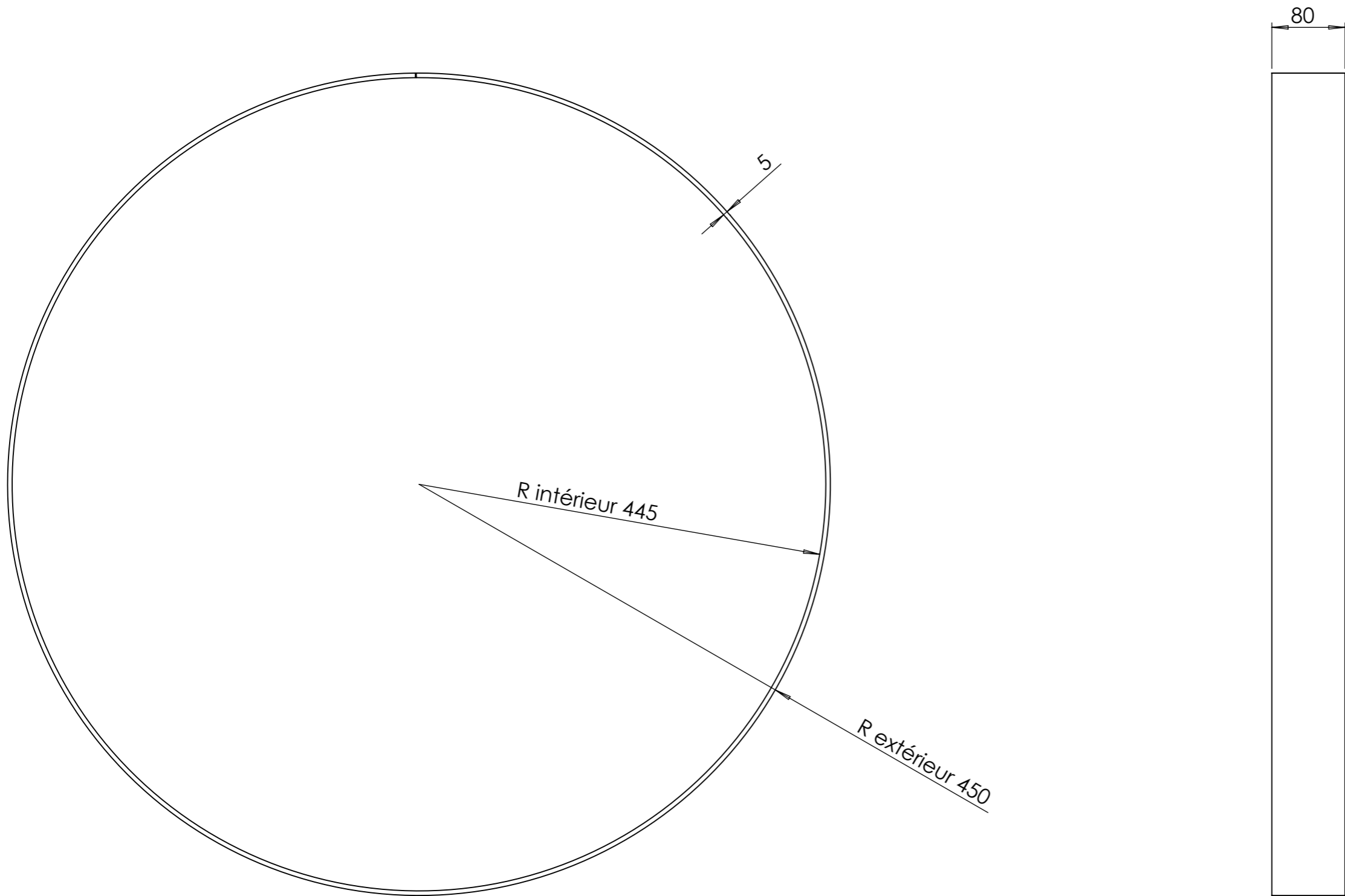

| repère | Désignation | ANGLE1 | ANGLE2 | p | LONGUEUR | Quantité |
|--------|-----------------|--------|--------|---|----------|----------|
| R2 | Fer plat 80 x 5 | 0° | 0° | | 2810.731 | 1 |

| | | | | |
|---------|------------------|---------|--|---|
| Outil | R3 | | |  |
| Date | 19/10/2021 | Version | | |
| Feuille | Feuille 1 | | | |

