

## Nomenclature générale pour largeur 50cm

repère	Désignation	ANGLE1	ANGLE2	p	LONGUEUR	Quantité
Vis Hexagonale	Vis hexagonale M12 x 30					2
Ecrou	Ecrou M12 autofreiné					4
Rondelle	Rondelle Ø12 série MU					6
Manche Bois	manche bois					2
A5	étiré plat 20 x 10	75	-		320	5
A2	A2 - plaque pivot A - campagnole	28	-			2
A4	fer plat 40 x 5	0	0		30	2
B1-50	Cornière 50 x 50 x 5	0	0		510	1
B3	Cornière 50 x 50 x 5	0	0		270	2
B5	étiré rond Ø14	0	-		320	4
B2	B2 - plaque pivot B - campagnole	-	0			2
B4	B4 - plaque support roue - campagnole	0	0			2
Vis Hexagonale	Vis hexagonale M12 x 60 PF					2
A3	tube rond 48 x 3	0	0		100	2
A1-50	Cornière 50 x 50 x 5	0	0		498	1
roue	Roue en plastique Ø180, L=46mm, roulements Øint 12mm					2

50cm

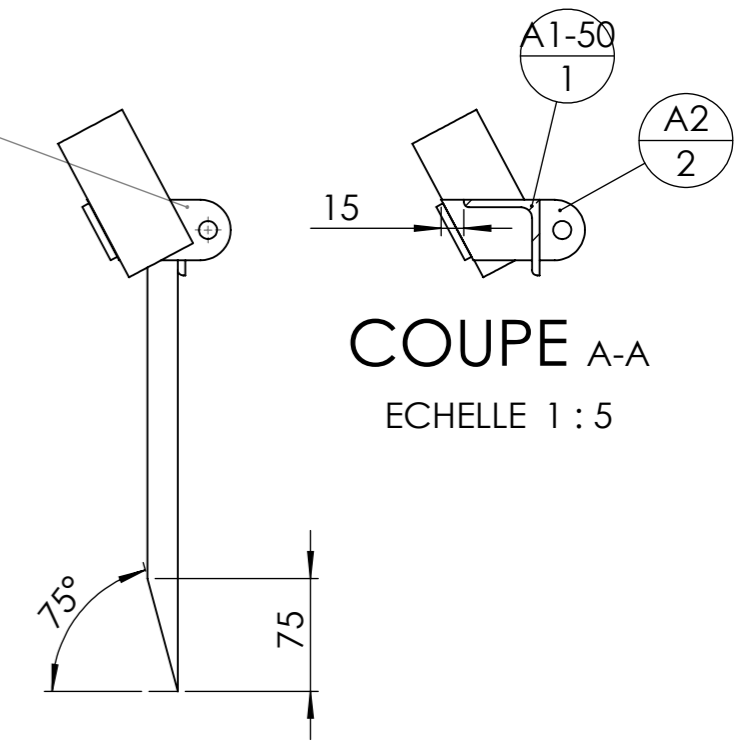
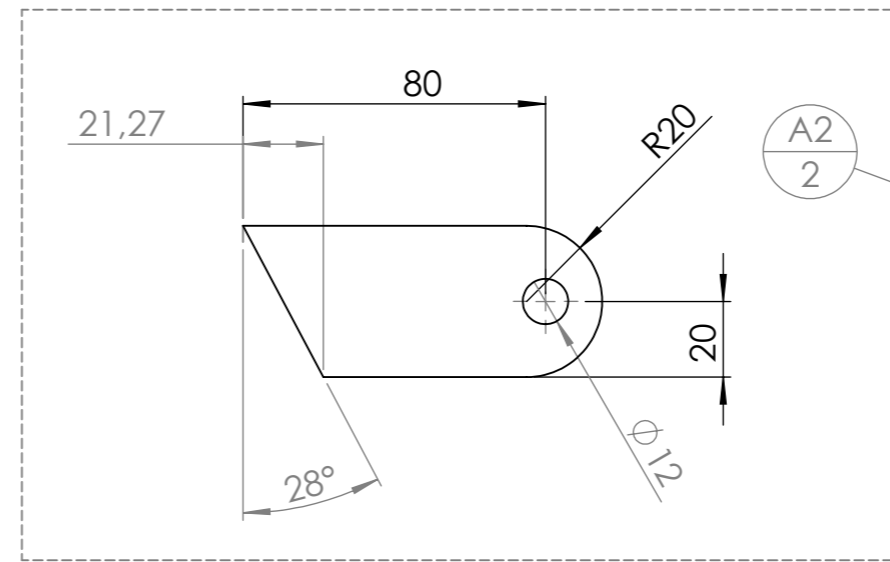
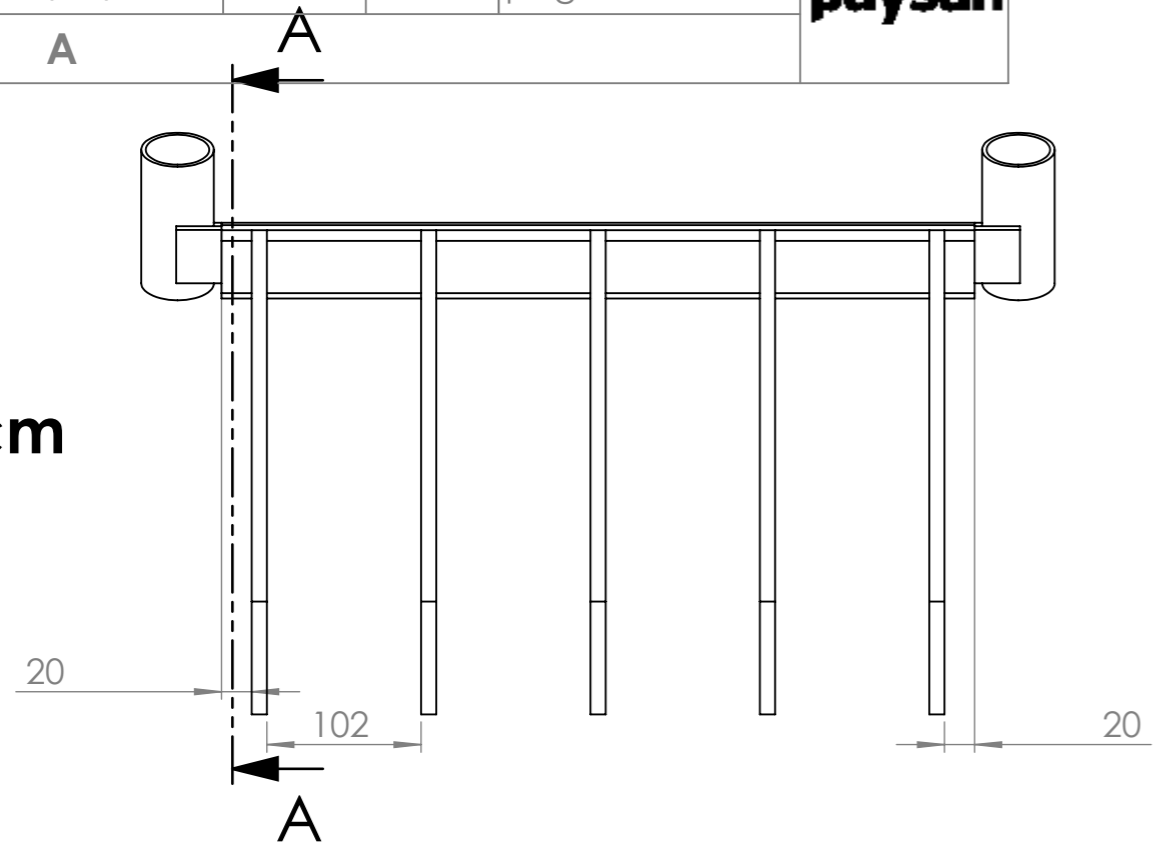

Autres largeurs

60cm

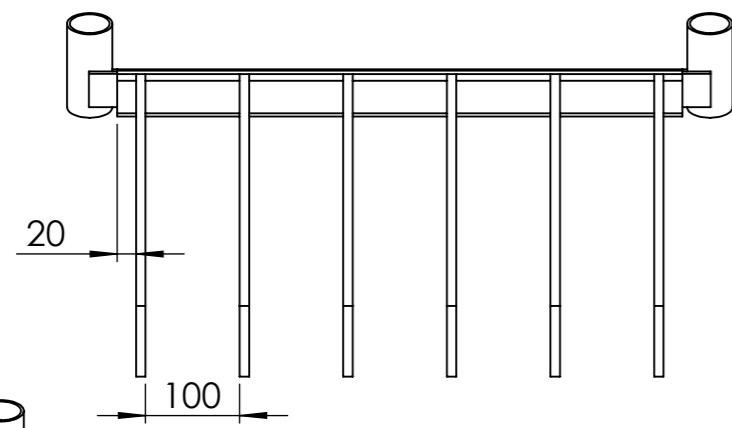

80cm

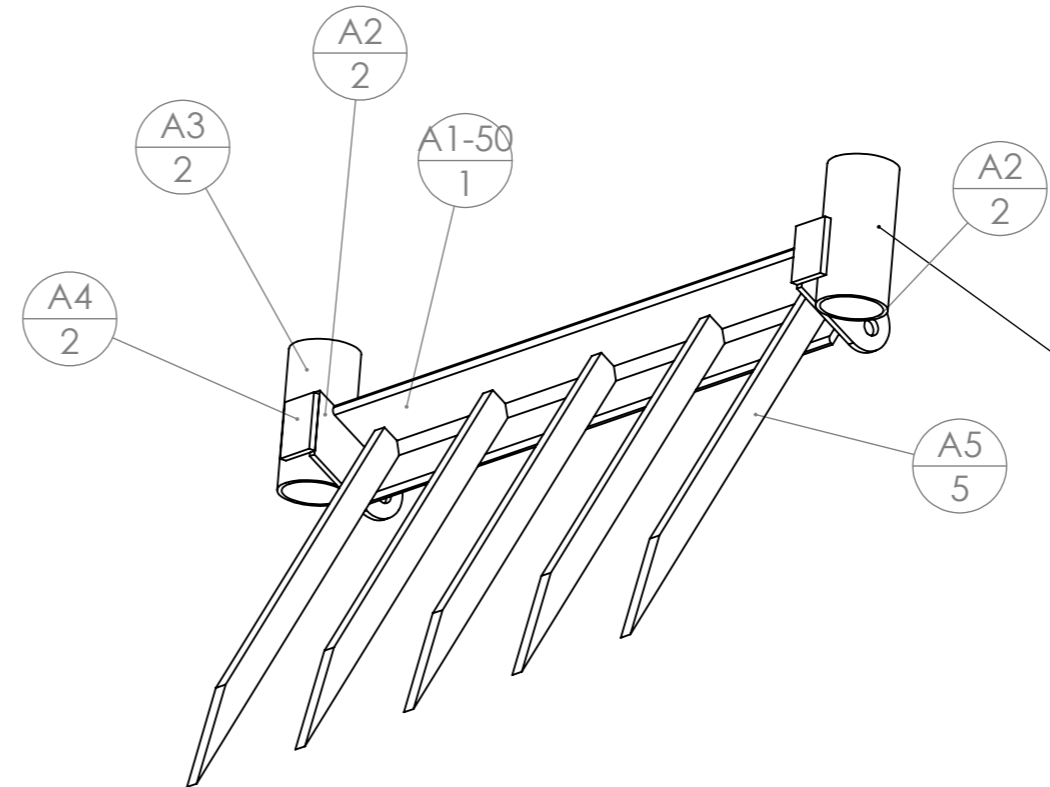
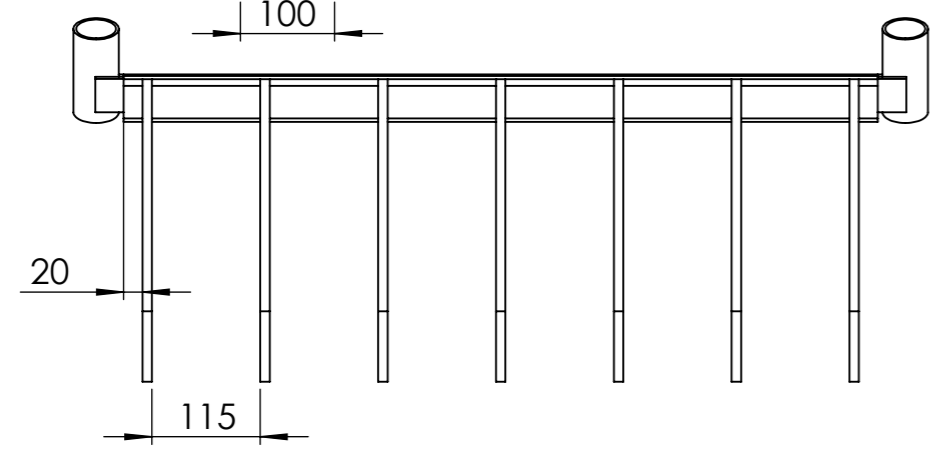

Les tubes ronds recevant les manches doivent être formés en cônes adaptés aux manches.

repère	Désignation	ANGLE1	ANGLE2	p	LONGUEUR	Quantité
A1-50	Cornière 50 x 50 x 5	0	0		498	1
A5	étiré plat 20 x 10	75	-		320	5
A2	A2 - plaque pivot A - campagnole	28	-			2
A3	tube rond 48 x 3	0	0		100	2
A4	fer plat 40 x 5	0	0		30	2

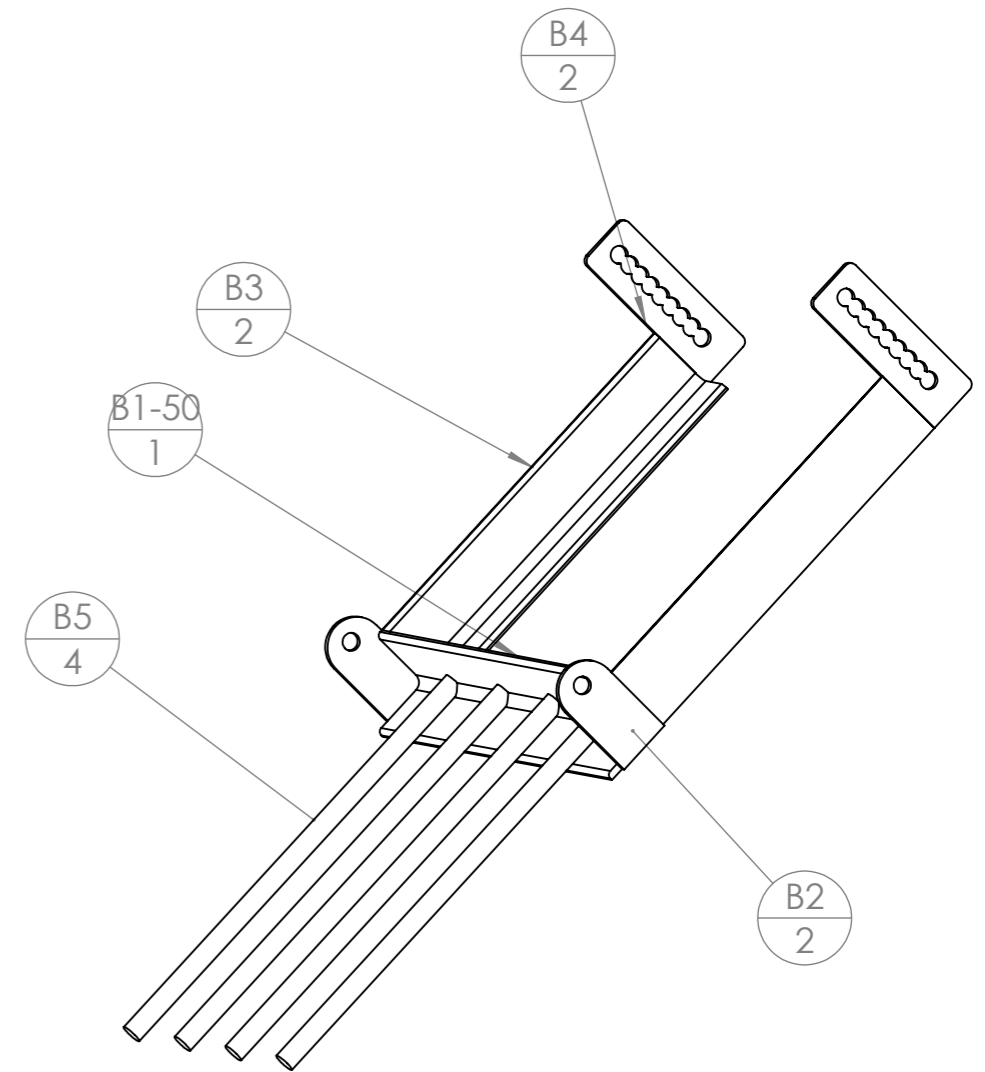
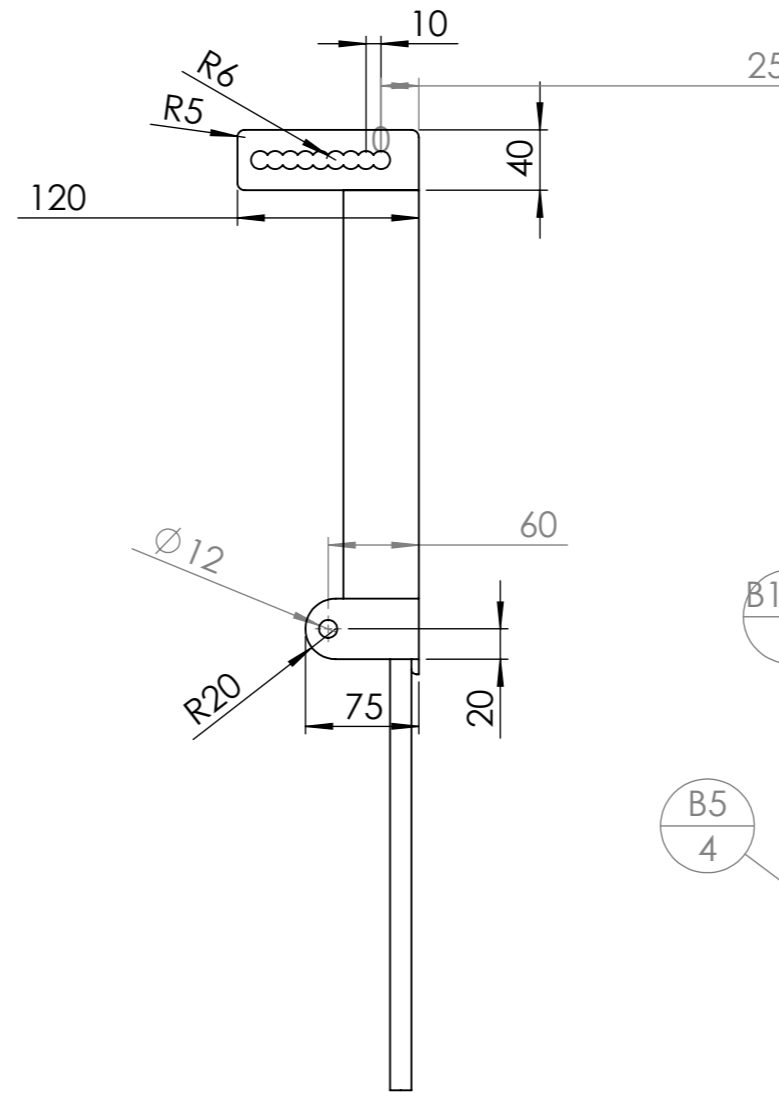
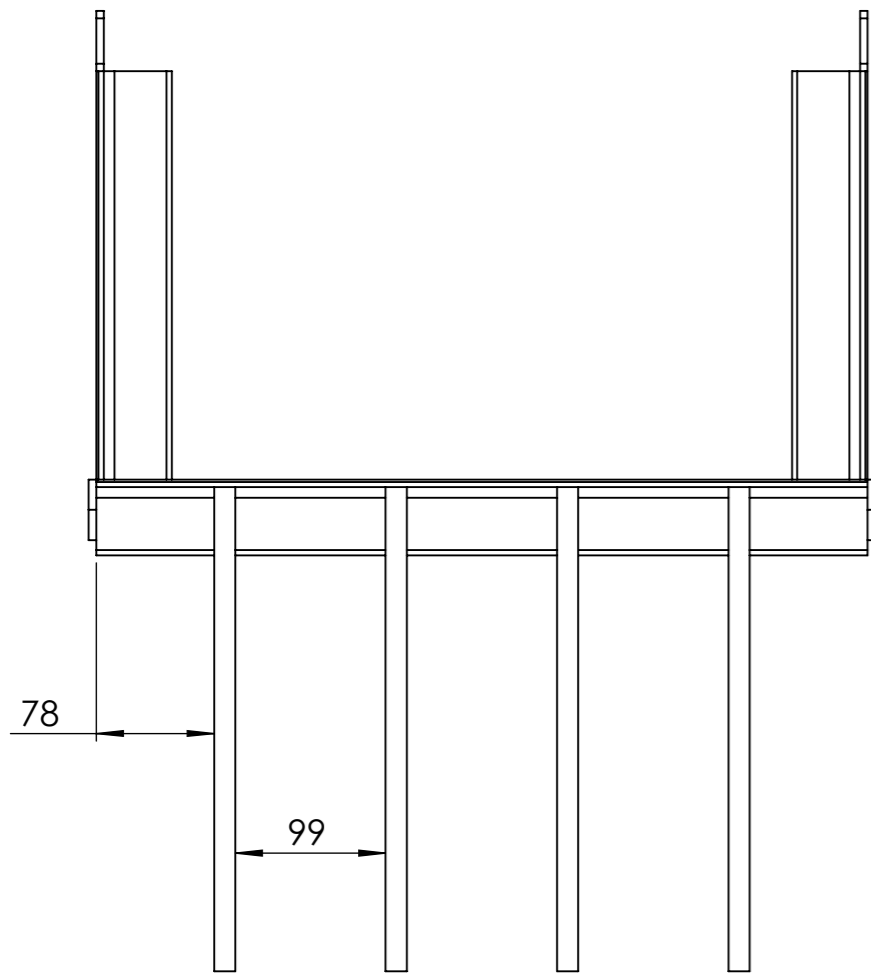

### Autres largeurs

**60cm**

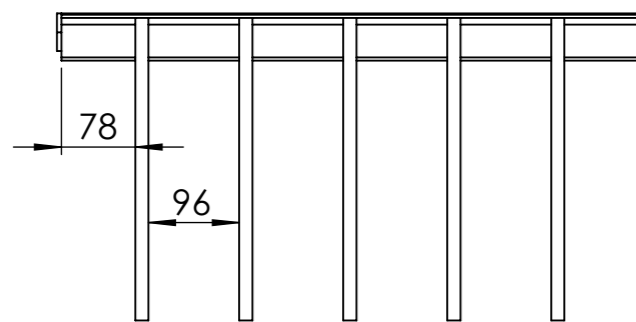

**80cm**

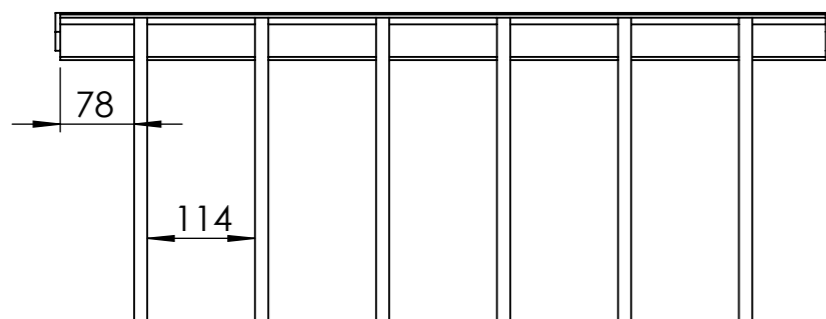

repère	Désignation	ANGLE1	ANGLE2	p	LONGUEUR	Quantité
B1-50	Cornière 50 x 50 x 5	0	0		510	1
B3	Cornière 50 x 50 x 5	0	0		270	2
B5	étiré rond Ø14	0	0		320	4
B2	B2 - plaque pivot B - campagnole	0	-			2
B4	B4 - plaque support roue - campagnole	-	0			2

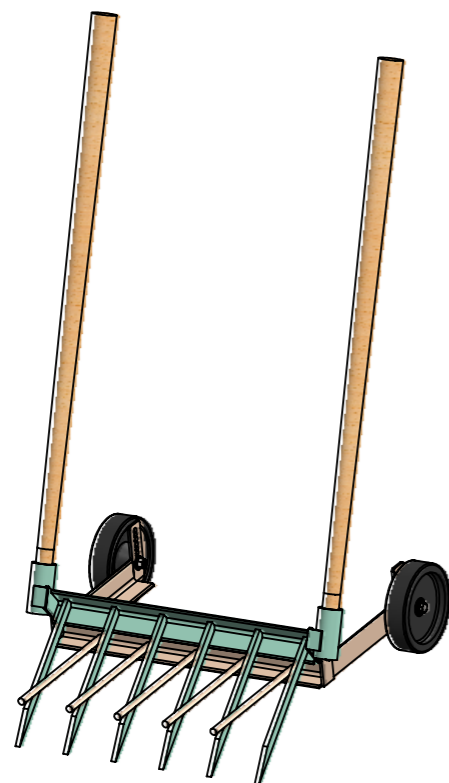

**Version 60cm**

repère	Désignation	ANGLE1	ANGLE2	p	LONGUEUR	Quantité
Vis Hexagonale	Vis hexagonale M12 x 30					2
Ecrou	Ecrou M12 autofreiné					4
Vis Hexagonale	Vis hexagonale M12 x 60 PF					2
Rondelle	Rondelle Ø12 série MU					6
Manche Bois	manche bois					2
A1-80	Cornière 50 x 50 x 5	0	0		798	1
A5	étiré plat 20 x 10	75	-		320	7
A2	A2 - plaque pivot A - campagnole	28	-			2
A3	tube rond 48 x 3	0	0		100	2
A4	fer plat 40 x 5	0	0		30	2
B1-80	Cornière 50 x 50 x 5	0	0		810	1
B3	Cornière 50 x 50 x 5	0	0		270	2
B5	étiré rond Ø14	0	-		320	6
B2	B2 - plaque pivot B - campagnole	-	0			2
B4	B4 - plaque support roue - campagnole	0	0			2
roue	Roue en plastique Ø180, L=46mm, roulements Øint 12mm					2

**Version 80cm**

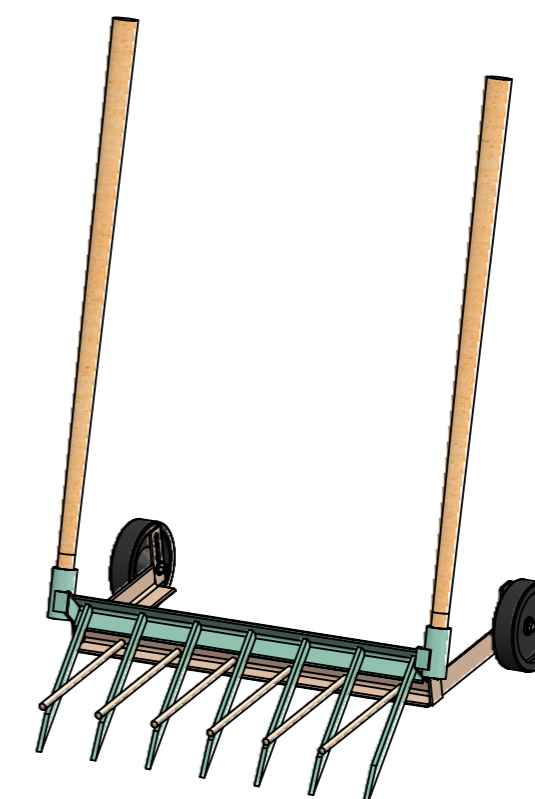

repère	Désignation	ANGLE1	ANGLE2	p	LONGUEUR	Quantité
Vis Hexagonale	Vis hexagonale M12 x 30					2
Ecrou	Ecrou M12 autofreiné					4
Vis Hexagonale	Vis hexagonale M12 x 60 PF					2
Rondelle	Rondelle Ø12 série MU					6
Manche Bois	manche bois					2
B1-60	Cornière 50 x 50 x 5	0	0		610	1
B3	Cornière 50 x 50 x 5	0	0		270	2
B5	étiré rond Ø14	0	-		320	5
B2	B2 - plaque pivot B - campagnole	-	0			2
B4	B4 - plaque support roue - campagnole	0	0			2
A1-60	Cornière 50 x 50 x 5	0	0		598	1
A5	étiré plat 20 x 10	75	-		320	6
A2	A2 - plaque pivot A - campagnole	28	-			2
A3	tube rond 48 x 3	0	0		100	2
A4	fer plat 40 x 5	0	0		30	2
roue	Roue en plastique Ø180, L=46mm, roulements Øint 12mm					2