

N°	Désignation	Quantité
SB	SB - Bielle parallélogramme	2
SC	SC - partie inf. parallélogramme	1
SD	SD - Bras dent latérale	2
SE	SE - support roue parallélogramme	1
SA	SA - Partie sup parallélogramme	1
SP ressort traction	Ressort traction 3,43 x 25,40 x 127	1
Rondelle	Rondelle Ø14 série MU	8
SF	F - Dent de binage + soc 140mm	2
Ecrou	Ecrou M14 autofreiné	6
Vis Hexagonale	Vis Hexagonale M14 x 100 PF	4
Ecrou	Ecrou M14 Zingué	6
Vis Hexagonale	Vis hexagonale M14 x 30	6
Vis Hexagonale	Vis hexagonale M14 x 60	6
SF	F - Dent de binage + soc 200mm	1
Vis Hexagonale	Vis hexagonale M14 x 140	1
Vis M14 x 140 coupée	Vis hexagonale M14 x 140	1
R		1
Palier lisse à collerette	Palier lisse à collerette Iglidur® Øint 14 - Øext 16 - L21	2
SG		1
Vis Hexagonale	Vis hexagonale M14 x 30	1

Outil	Parallélogramme BPO		
Date	21/04/2020	Version	1.6
	page n° 2 / 8		
Pièce	Encombrement	Qté	1

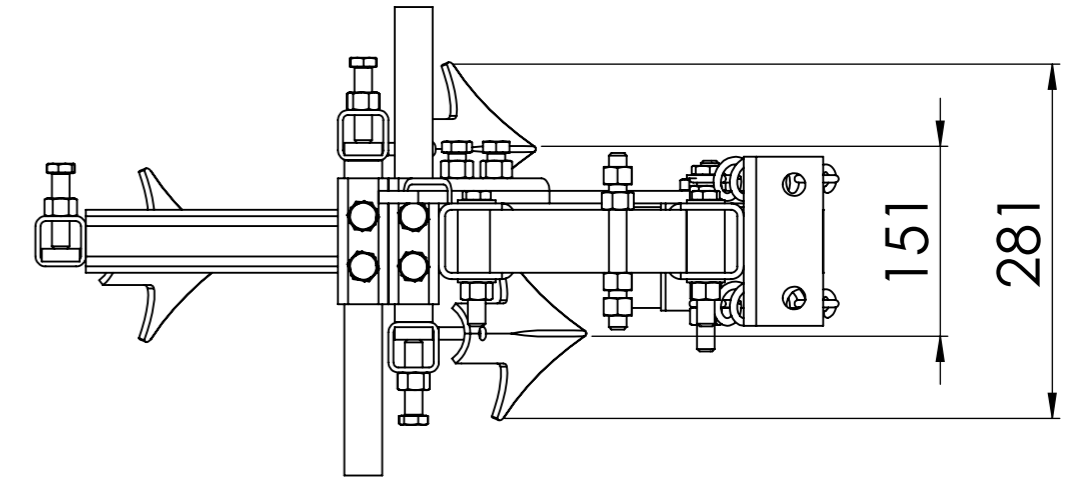

Outil	Parallélogramme BPO		
Date	21/04/2020	Version	1.6
Pièce	SA	Qté	1

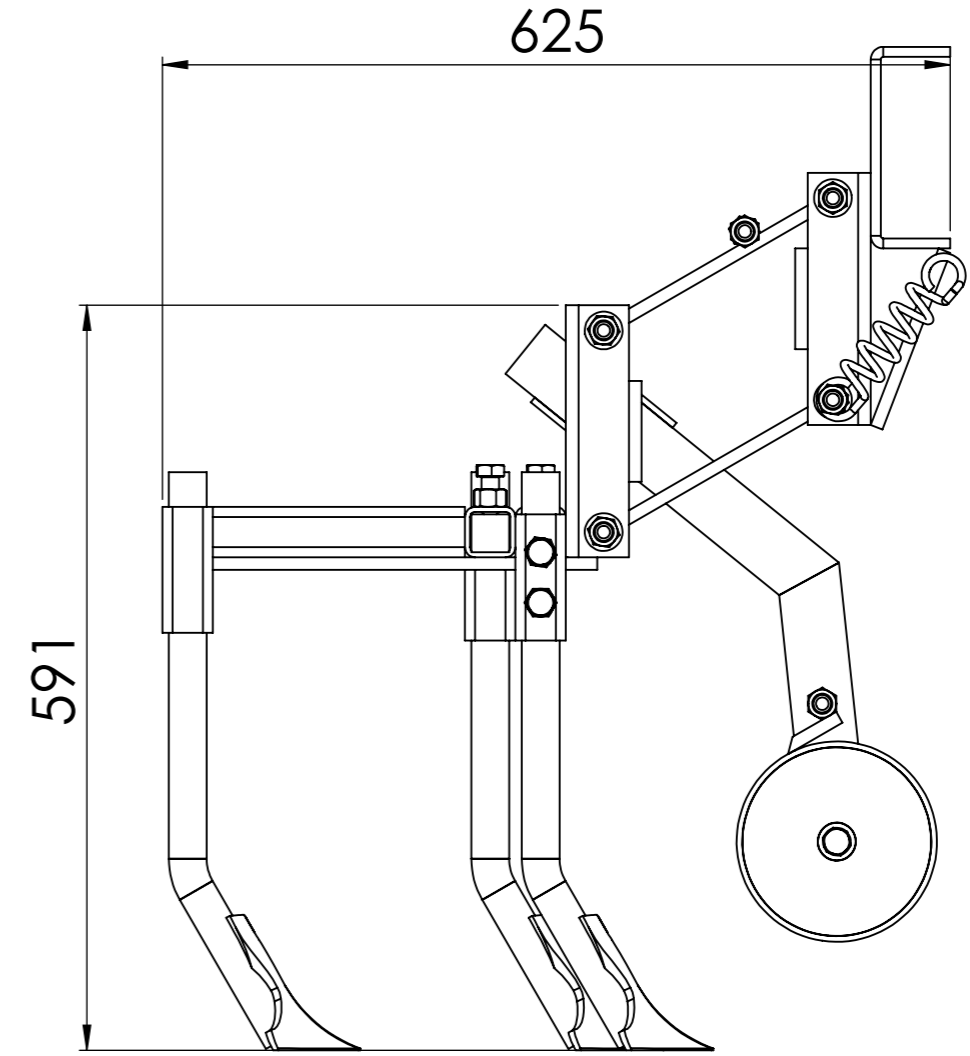
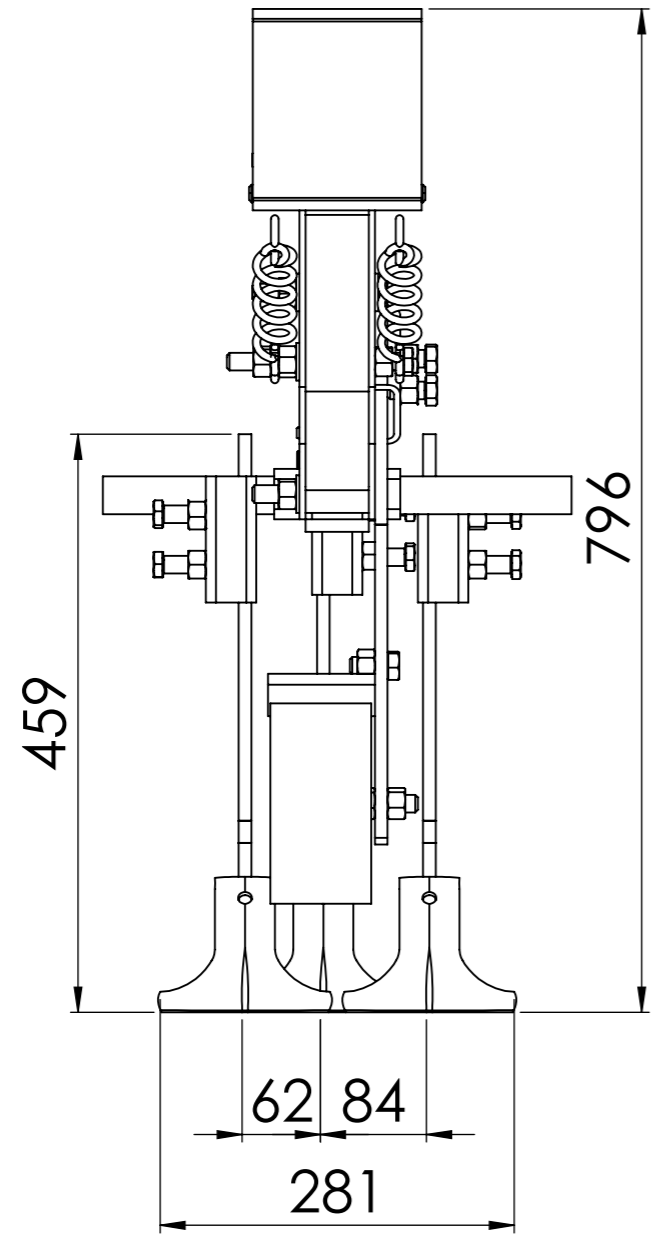
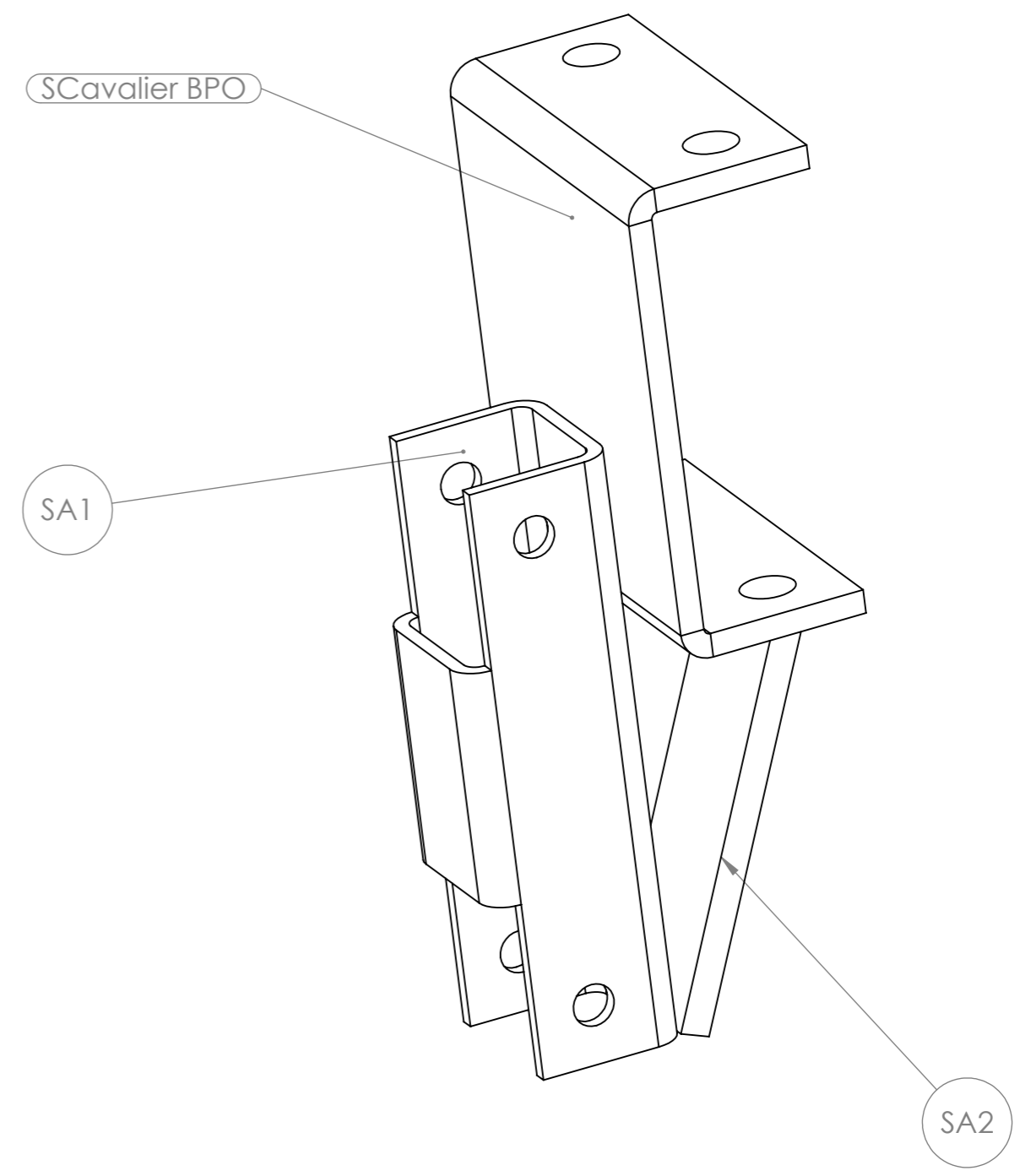
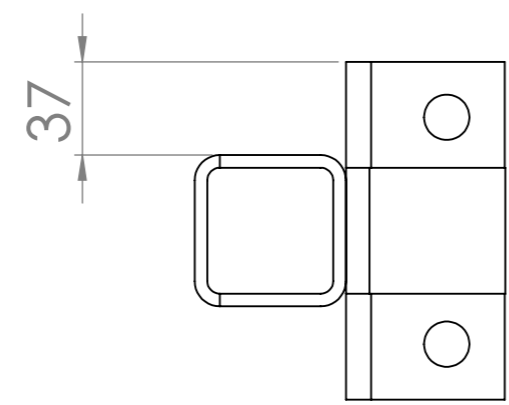
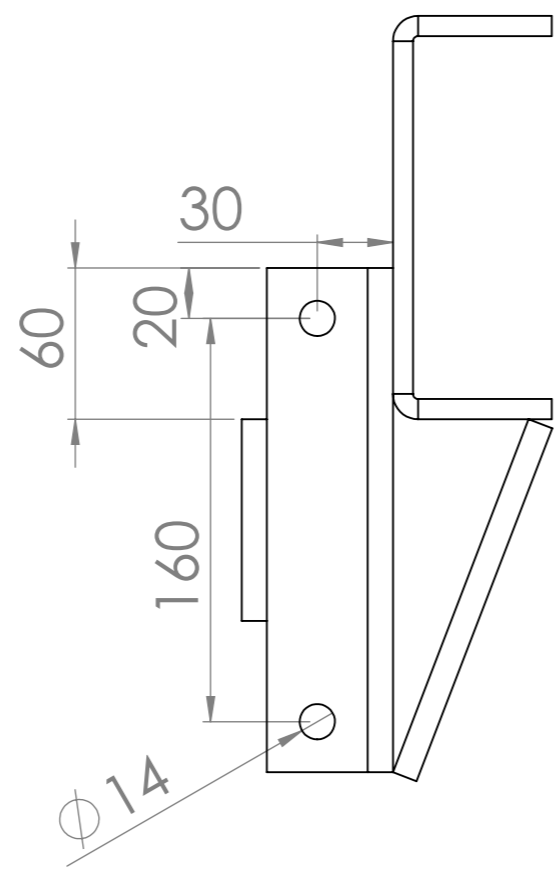
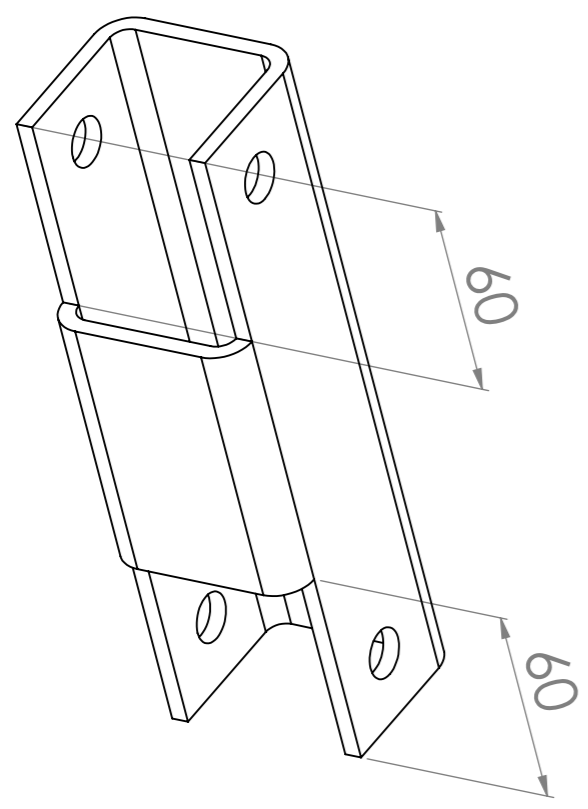

Couper une face du tube carré SA1 sur 60mm

N°	Désignation	Longueur	Qté
SA1	tube carré 60 x 5	200	1
SA2	Fer plat 50 x 10	150	1
SCavalier BPO	Cavalier BPO		1

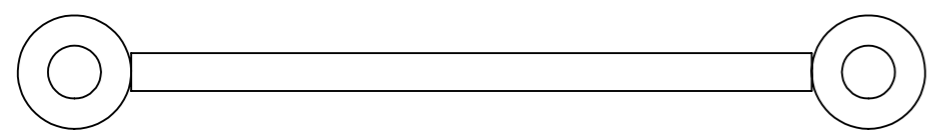
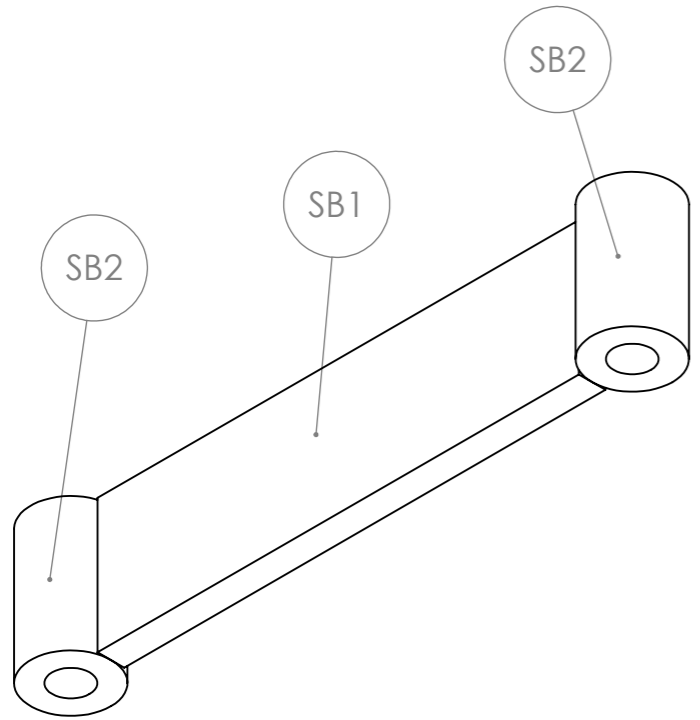

La coaxialité des tubes SB2 est primordiale

Nom	SB - Bielle parallélogramme	Qté	2
-----	-----------------------------	-----	---

N°	Désignation	Longueur	Qté
SB1	Fer plat 50 x 10	180	1
SB2	Douille tournée Øint14/Øext30/l=49mm		2

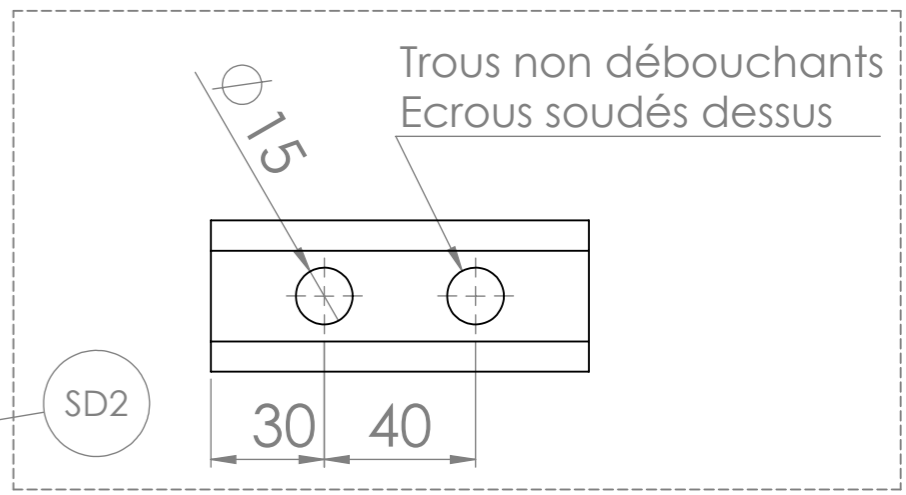
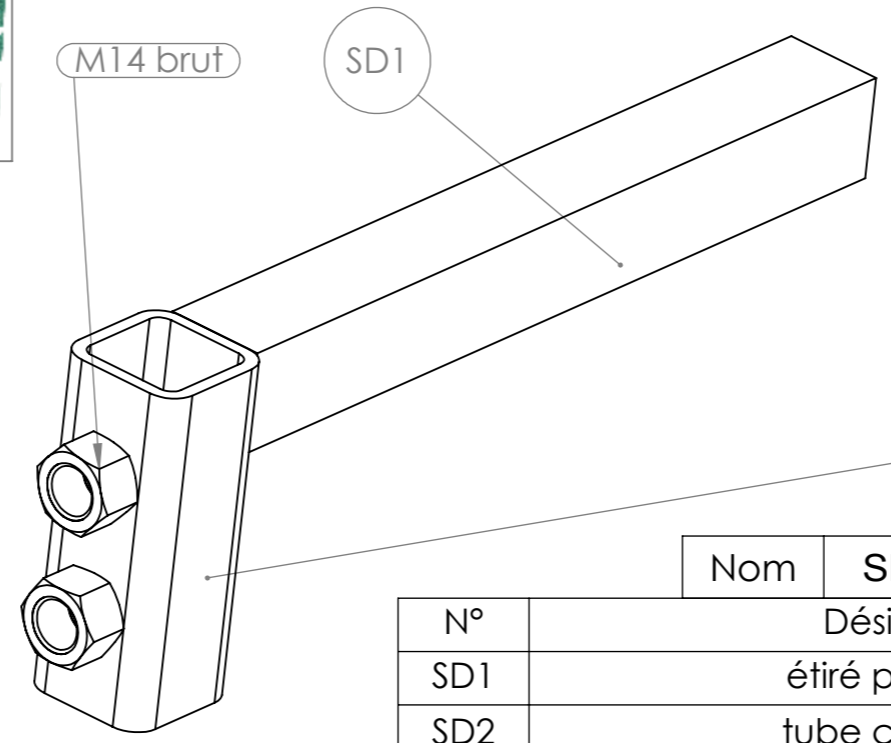

Nom	SD - Bras dent latérale	Qté	2
-----	-------------------------	-----	---

N°	Désignation	Longueur	Qté
SD1	étiré plat 30 x 30	250	1
SD2	tube carré 40 x 4	100	1
Ecrou	Ecrou M14 brut		2

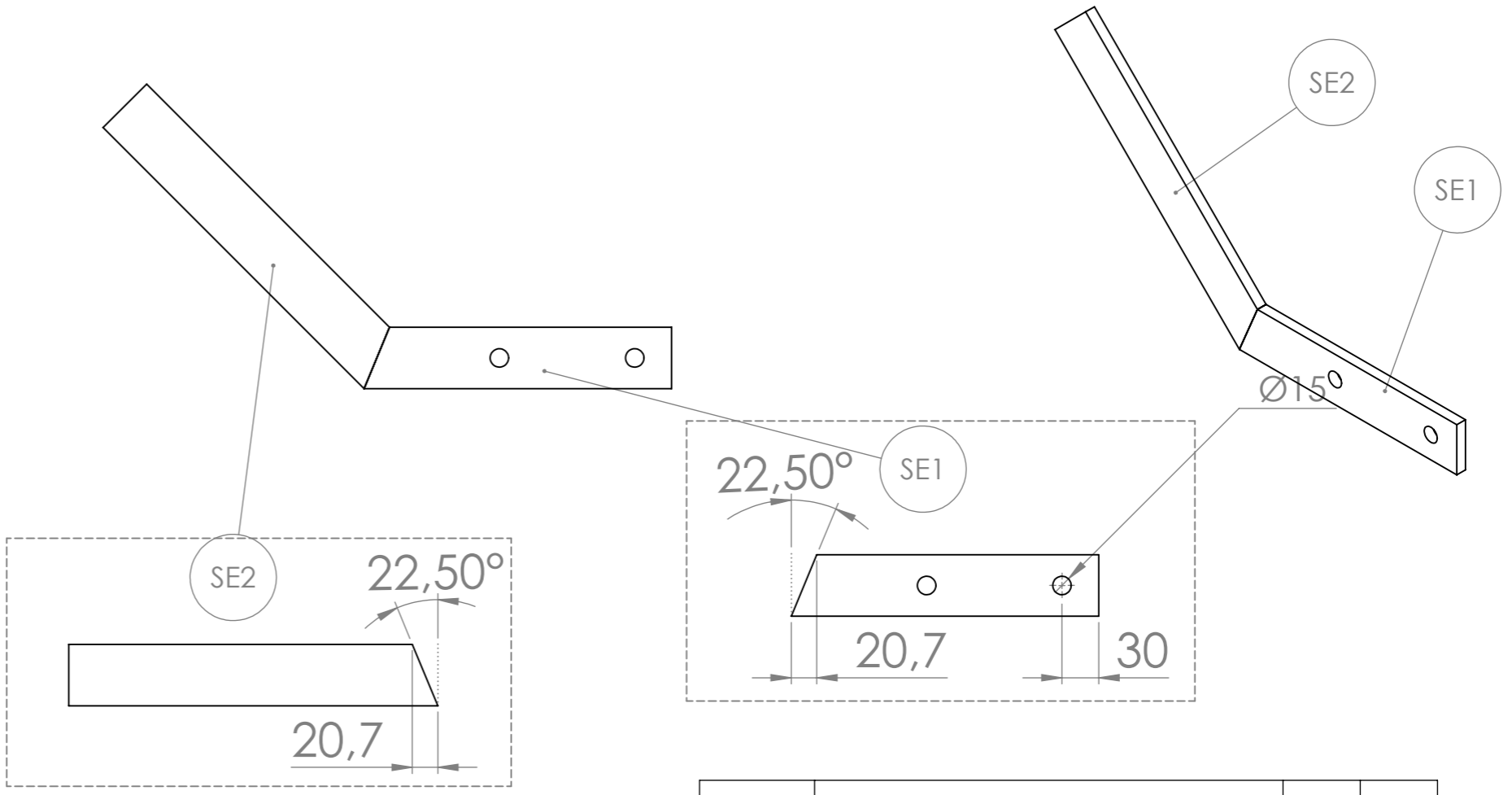

Nom	SE - Support de roue	Qté	1
-----	----------------------	-----	---

N°	Désignation	Longueur	Qté
SE1	Fer plat 50 x 10	250	1
SE2	Fer plat 50 x 10	300	1



SC1 est identique à SA1

N°	Désignation	Longueur	Qté
SC1	tube carré 60 x 5	200	1
SC3	tube carré 40 x 4	100	3
SC4	tube carré 40 x 4	200	1
SC6	Fer plat 50 x 10	305	1
SC5	tube carré 60 x 5	100	1
Ecrou	Ecrou M14 brut		8

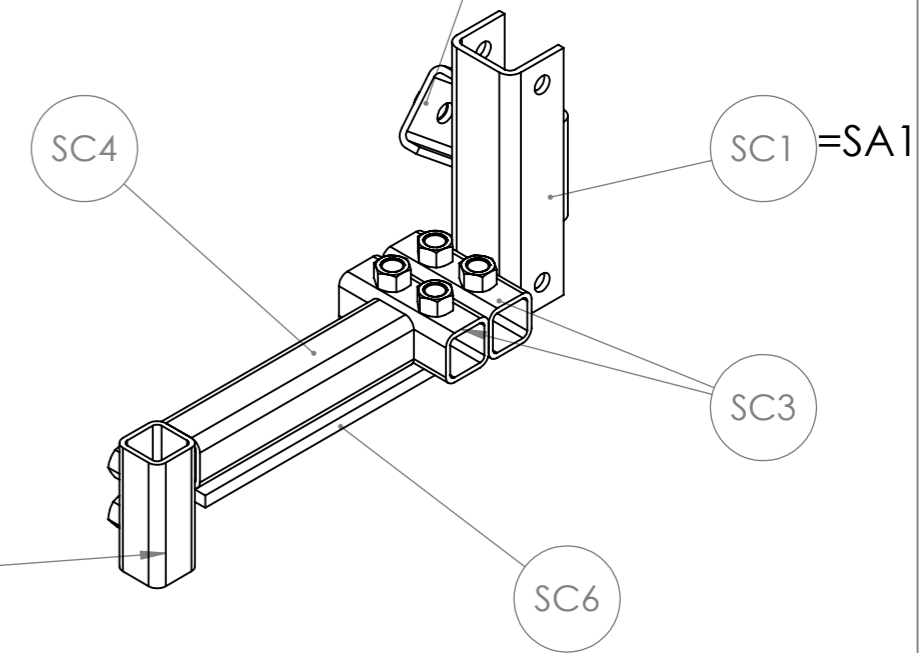
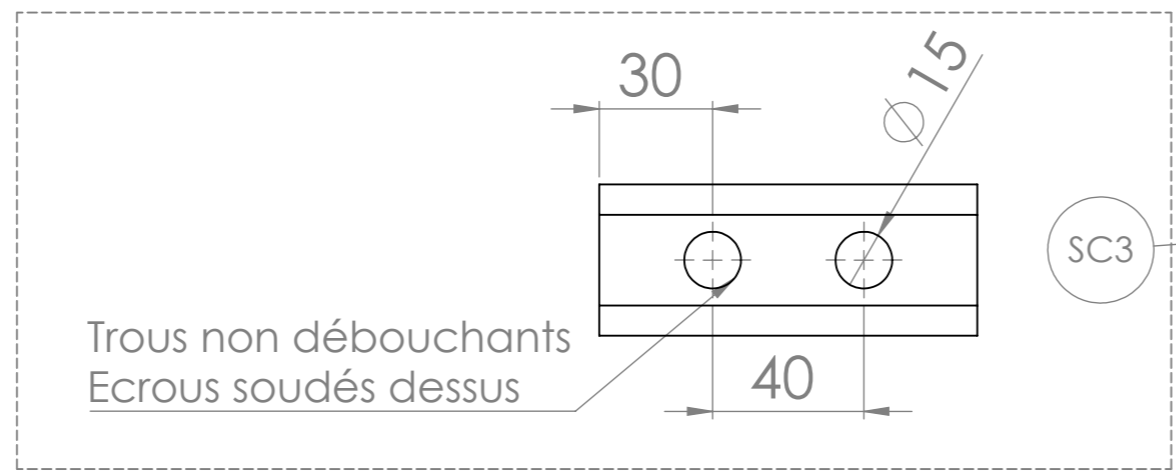
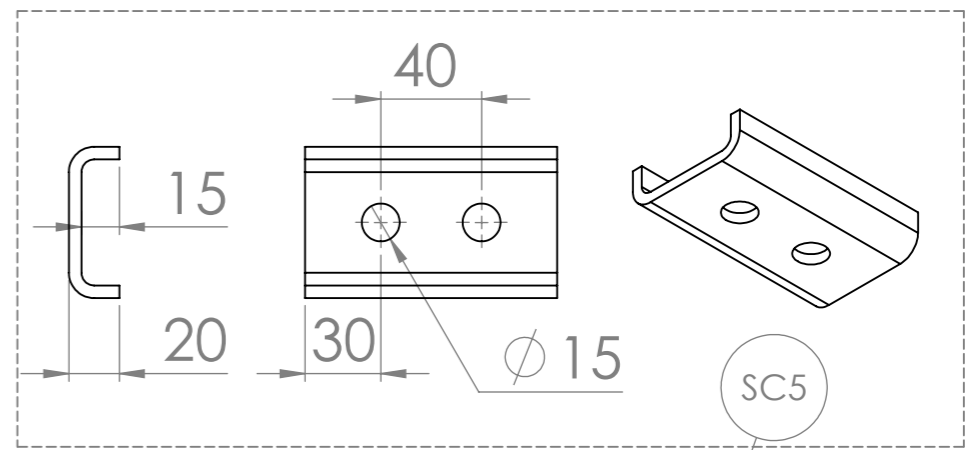
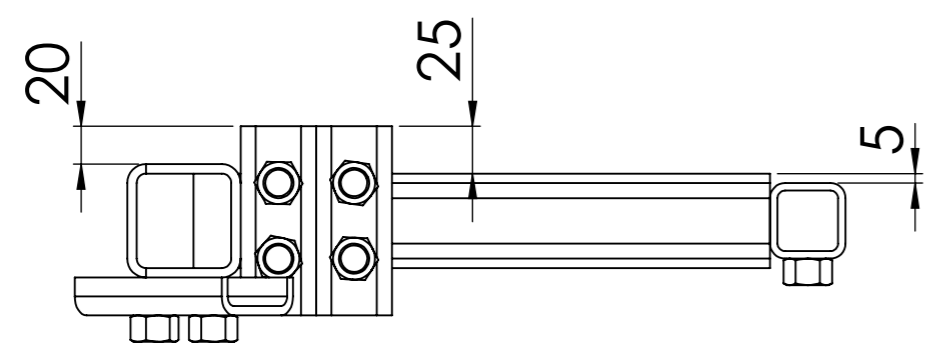
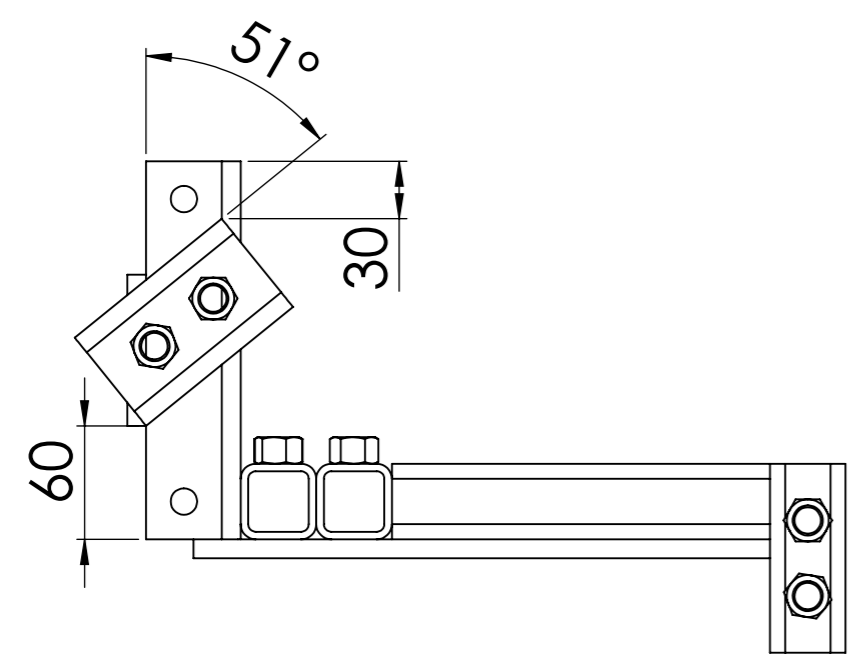

Outil	Parallélogramme BPO		
Date	21/04/2020	Version	1.6
		page n°	6 / 8
Pièce	SG - décroeur	Qté	1

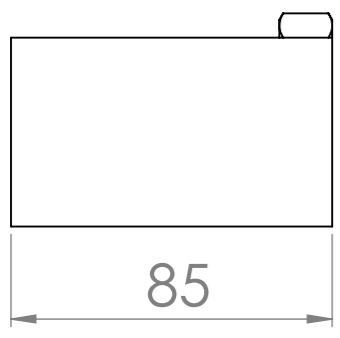
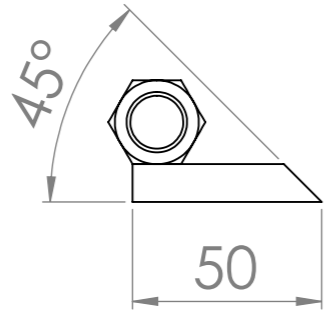
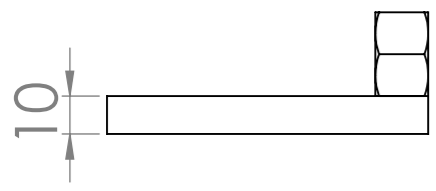
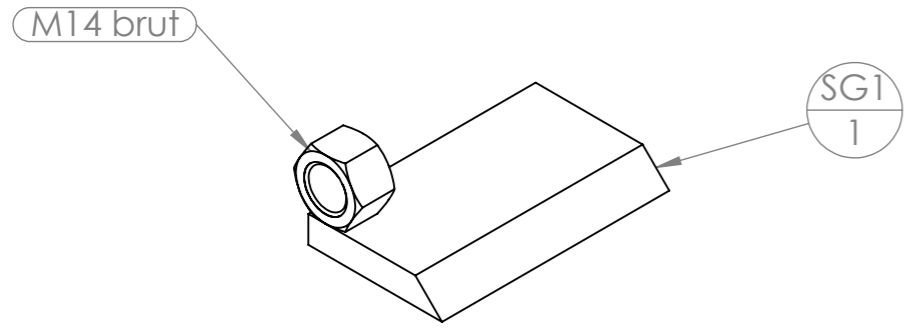

c	Désignation	Longueur	Qté
SG1	Fer plat 50 x 10	85	1
ecrou2	Ecrou M14 brut		1

Outil	Parallélogramme BPO		
Date	21/04/2020	Version	1.6 page n° 7 / 8
Pièce	Montage parallélogramme	Qté	1



Monter les bras B dans B1 et C1 avec des vis M14x100

Couper la tête d'une vis M14x140, et la souder sur le fer plat

Coincer l'extrémité du ressort sur cette vis entre deux écrous M14

Coincer ce côté du ressort dans la vis M14x100

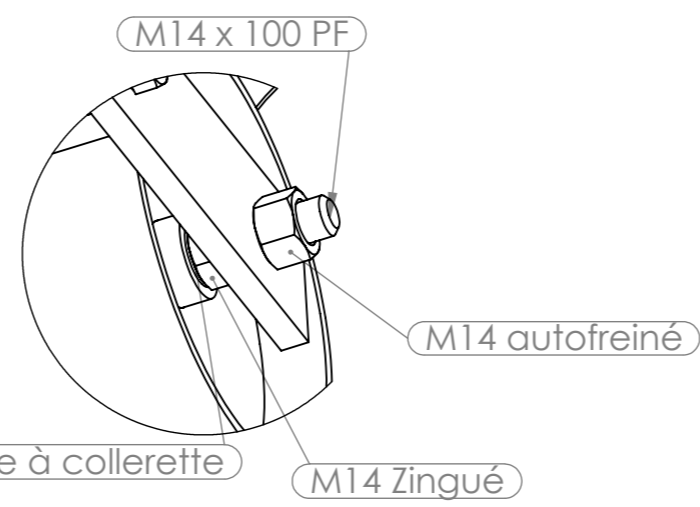
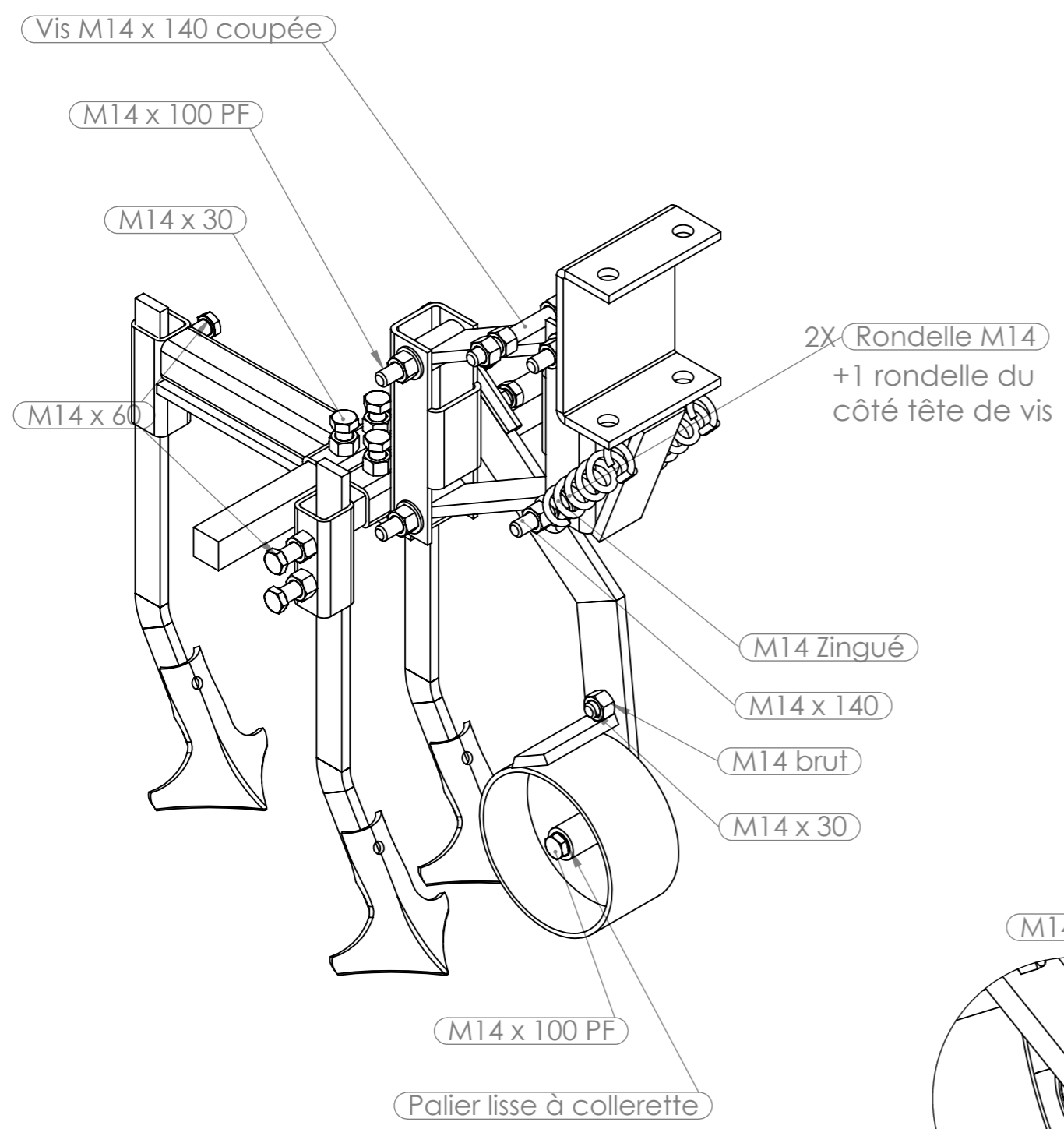

DÉTAIL A  
ECHELLE 2 : 5  
Fixation de la roue

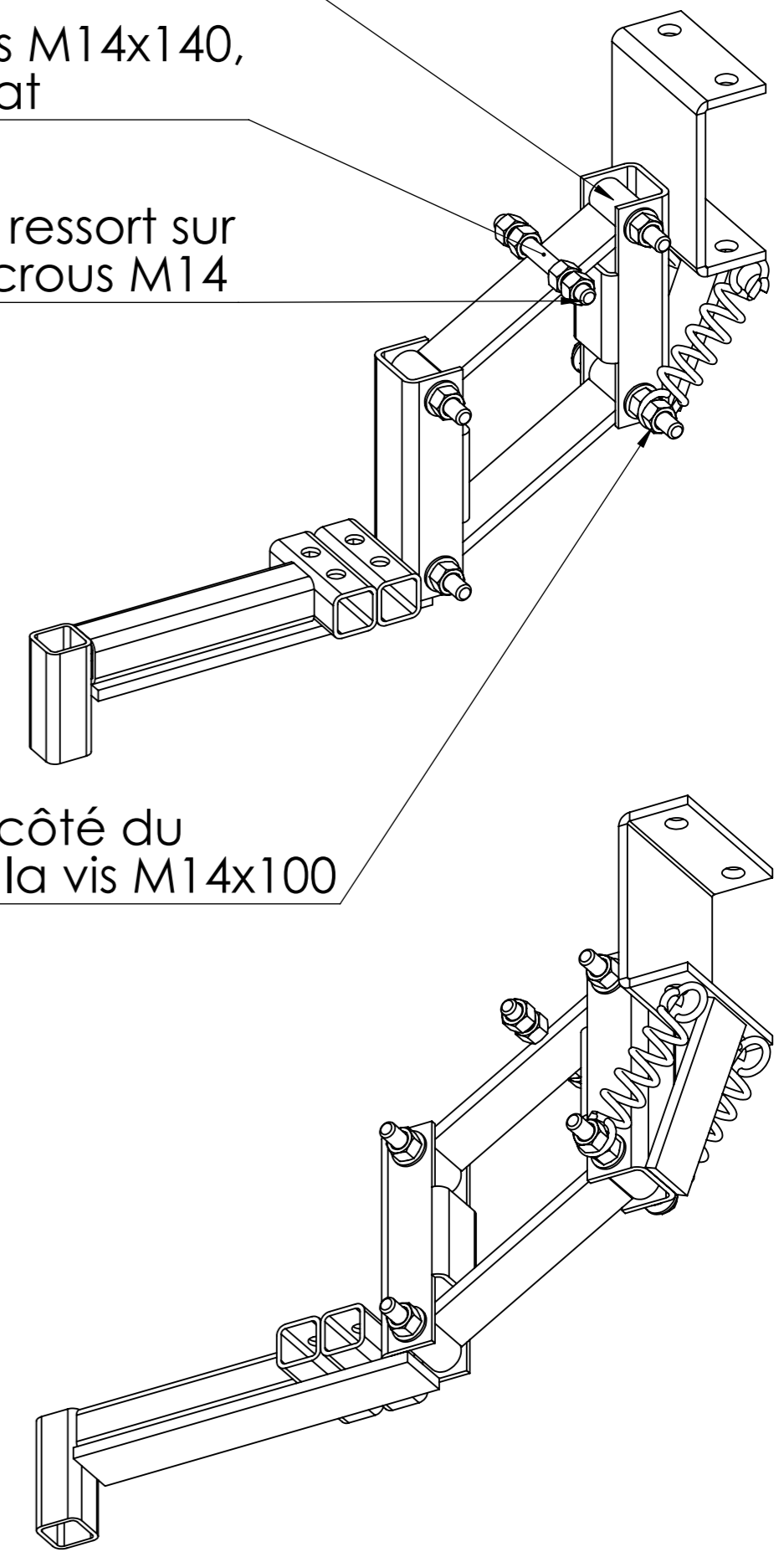

Outil	Parallélogramme BPO				
Date	21/04/2020	Version	1.6	page n° 8 / 8	
Pièce	Nomenclature générale		Qté	1	

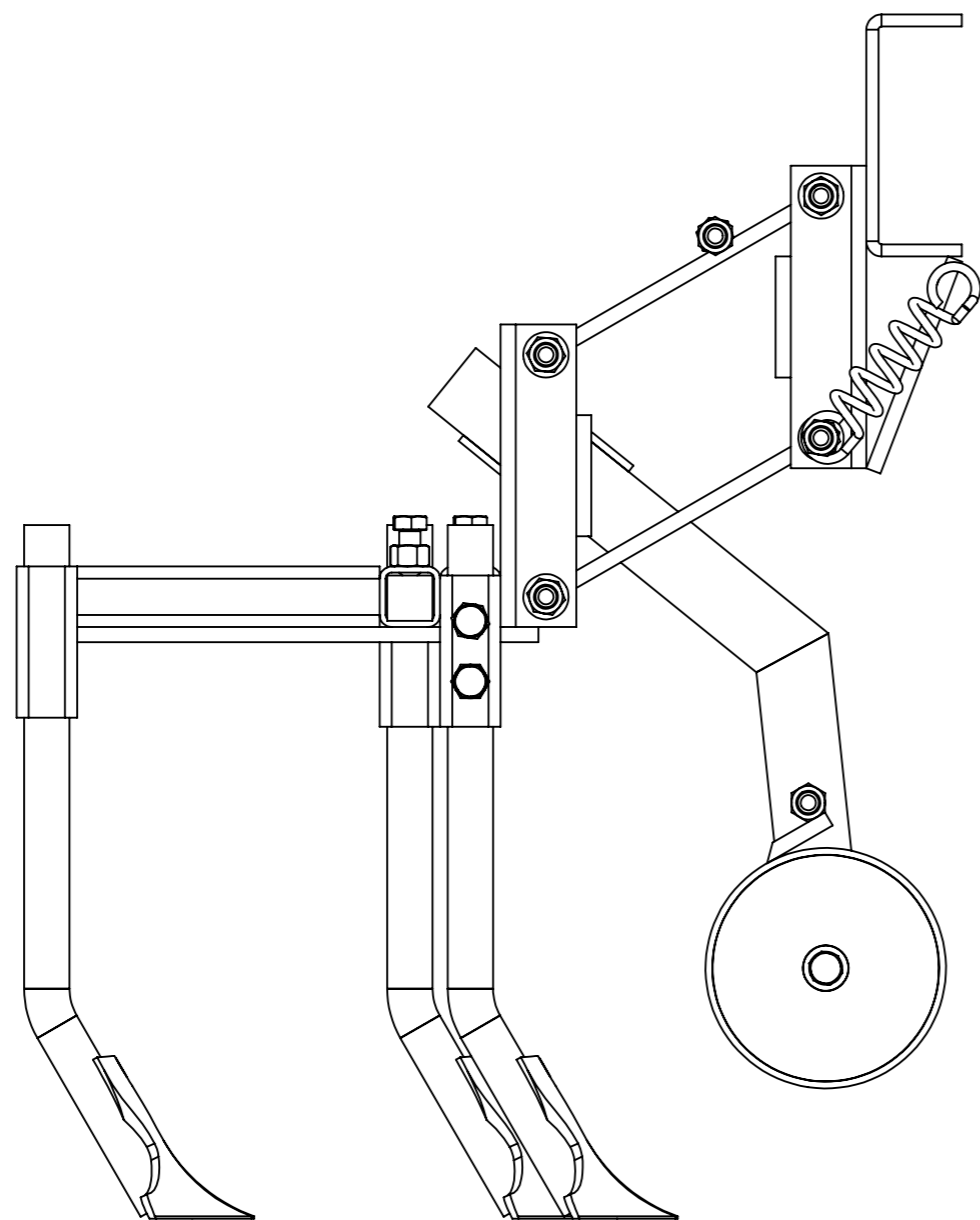

Les socs sont soudés aux dents

N°	Désignation	Longueur	Qté
SCavalier BPO	Cavalier BPO		1
Ecrou	Ecrou M14 autofreiné		6
SB1	Fer plat 50 x 10	180	2
SC6	Fer plat 50 x 10	305	1
SA2	Fer plat 50 x 10	150	1
SE1	Fer plat 50 x 10	250	1
SE2	Fer plat 50 x 10	300	1
SF1	Tige 30x10 pour dent bineuse		3
Rondelle	Rondelle Ø14 série MU		8
SP ressort traction	Ressort traction 3,43 x 25,40 x 127		2
SC3	tube carré 40 x 4	100	3
SC4	tube carré 40 x 4	200	1
SD2	tube carré 40 x 4	100	2
SC1	tube carré 60 x 5	200	1
SC5	tube carré 60 x 5	100	1
SA1	tube carré 60 x 5	200	1
SB2	Douille tournée Øint14/Øext30/l=49mm		4
SD1	étiré plat 30 x 30	250	2
Soc patte d'oie	Soc patte d'oie vibroplanche		3
Vis Hexagonale	Vis Hexagonale M14 x 100 PF		4
Ecrou	Ecrou M14 Zingué		6
Vis Hexagonale	Vis hexagonale M14 x 30		6
Vis Hexagonale	Vis hexagonale M14 x 60		6
Ecrou	Ecrou M14 brut		12
Vis Hexagonale	Vis hexagonale M14 x 140		1
Vis M14 x 140 coupée	Vis hexagonale M14 x 140		1
R1	R1 Flasque roue de jauge		1
R2	Tube rond 159 x 4,5	80	1
Bague tournée	bague tournée Øint 16 - Øext 30 - L 50		1
Palier lisse à collerette	Palier lisse à collerette Iglidur® Øint 14 - Øext 16 - L21		2
SG1	Fer plat 50 x 10	85	1
ecrou2	Ecrou M14 brut		1
Vis Hexagonale	Vis hexagonale M14 x 30		1