

Outil	Pièces sous traitées			
Date	17/06/2021	Version	page n° 7 / 28	
Feuille	B3			

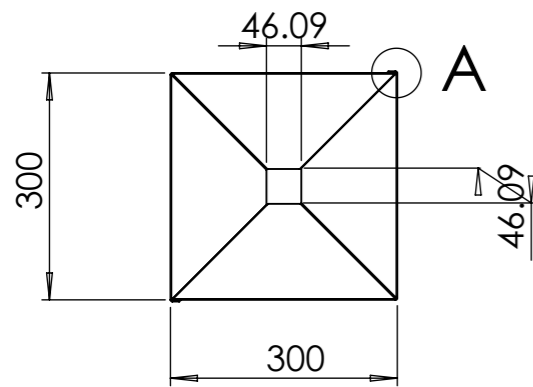

DÉTAIL A
ECHELLE 1 : 1

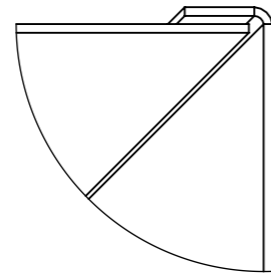
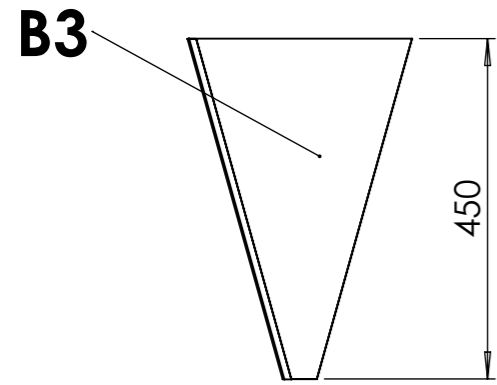
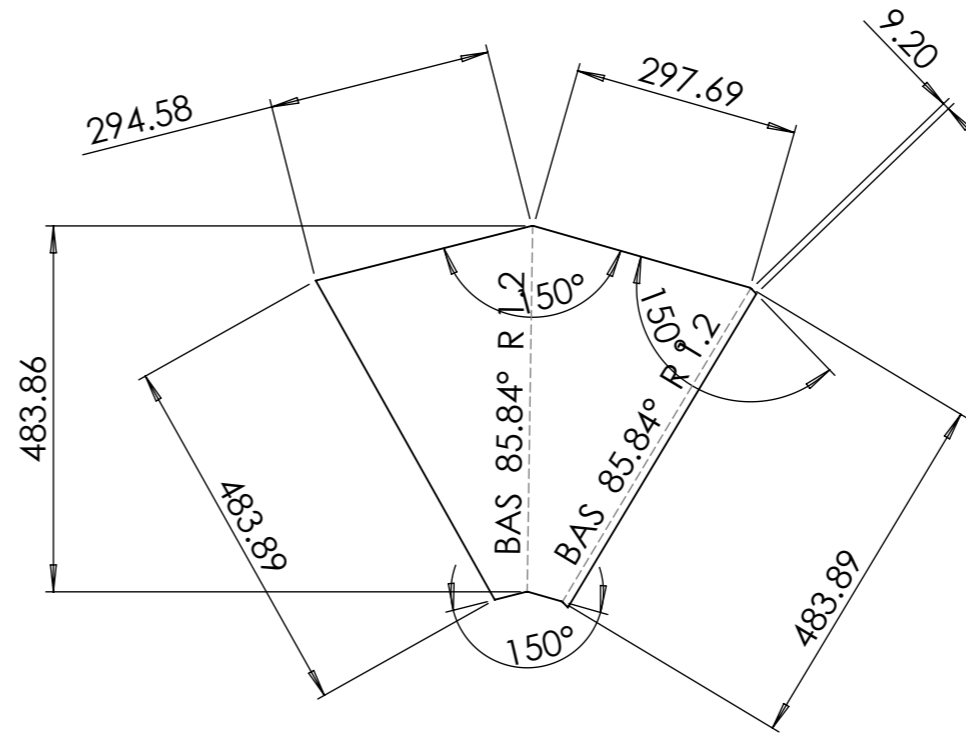

1.20

Matériau <non spécifié>