

Outil	Four à pain Ø1000				
Date	26/06/2019	Version	5.2	page n° 13 / 31	
Pièce	C - Châssis			Qté	

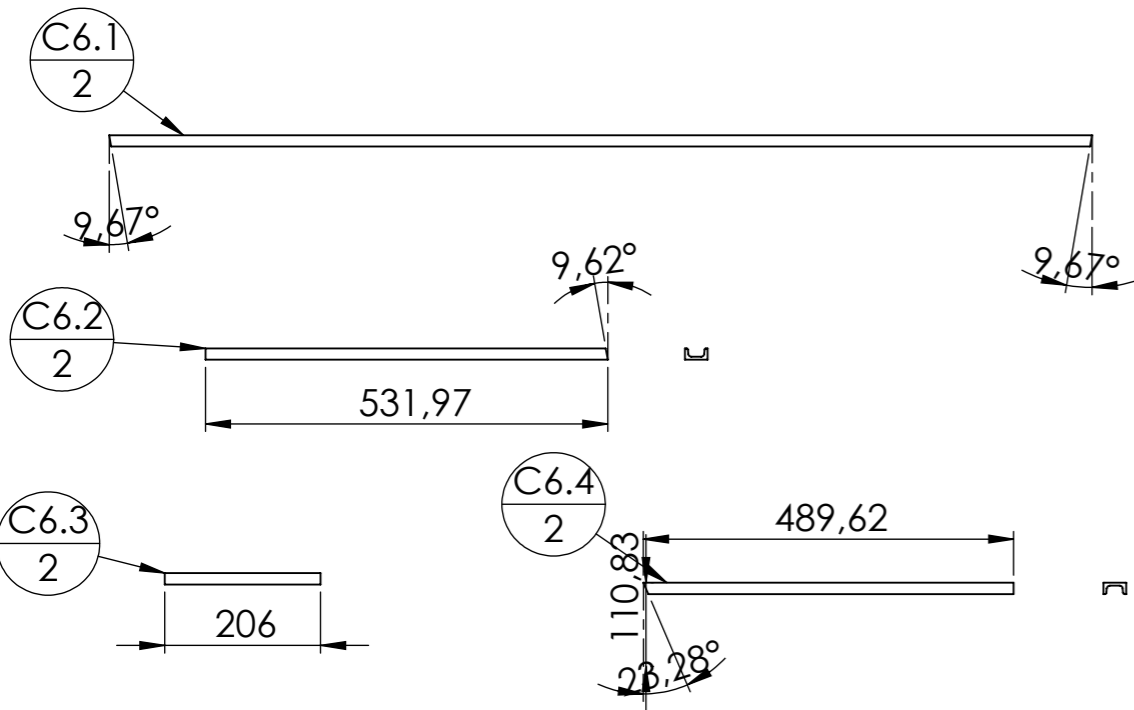

repère	Désignation	ANGLE1	ANGLE2	p	LONGUEUR	Quantité
C6.2	fer U 30 x 15 x 4	0.00	0.00		531.97	2
C6.3	fer U 30 x 15 x 4	9.67	9.67		206	2
C6.1	fer U 30 x 15 x 4	0.00	23.28		1299.78	2
C6.4	fer U 30 x 15 x 4	0.00	9.62		489.62	2

Position des pates C16 à ajuster en fonction de la poignée

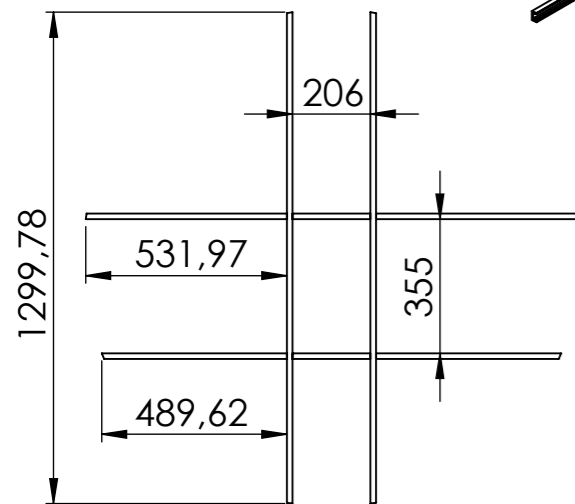
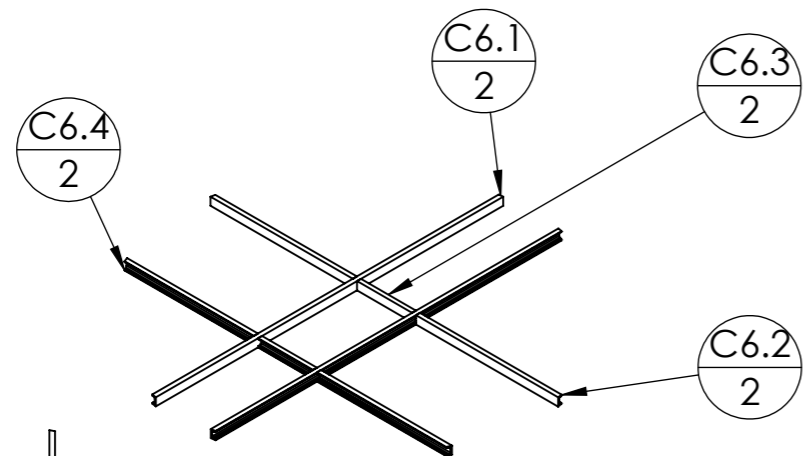
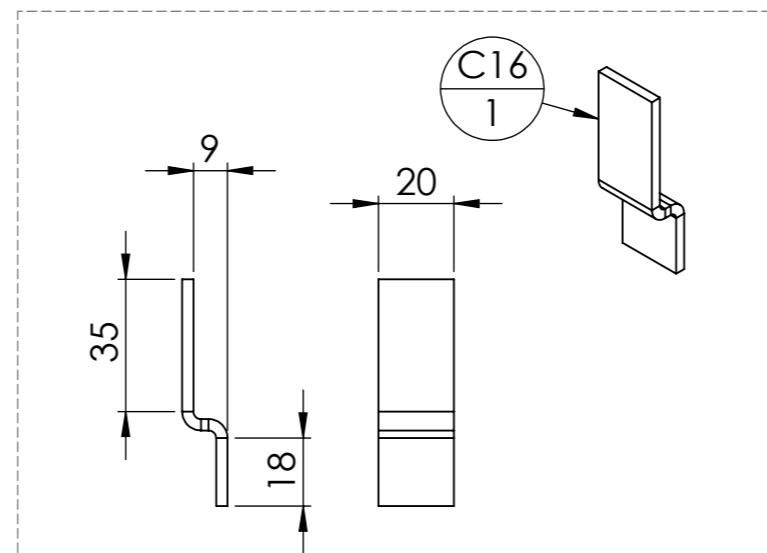
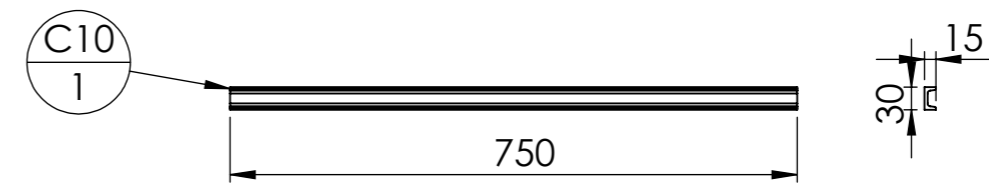
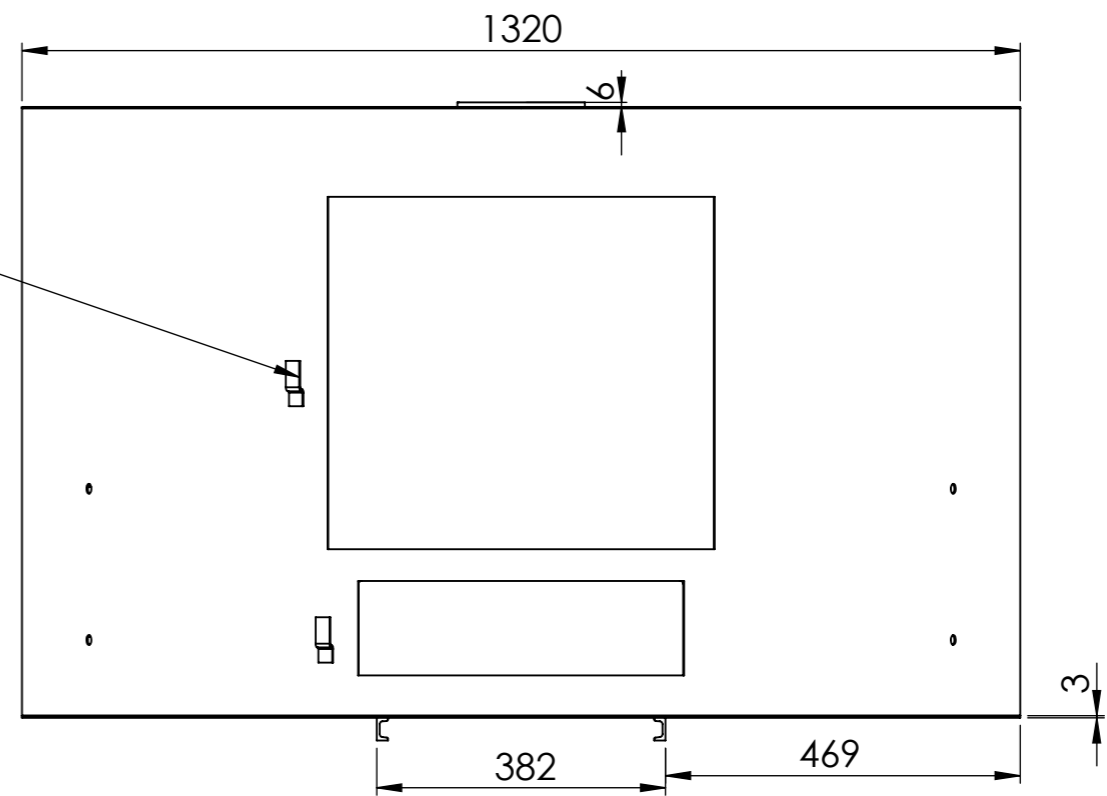

Repère	Désignation	Longueur	Qté
C16	Fer plat 20 x 3	70	1

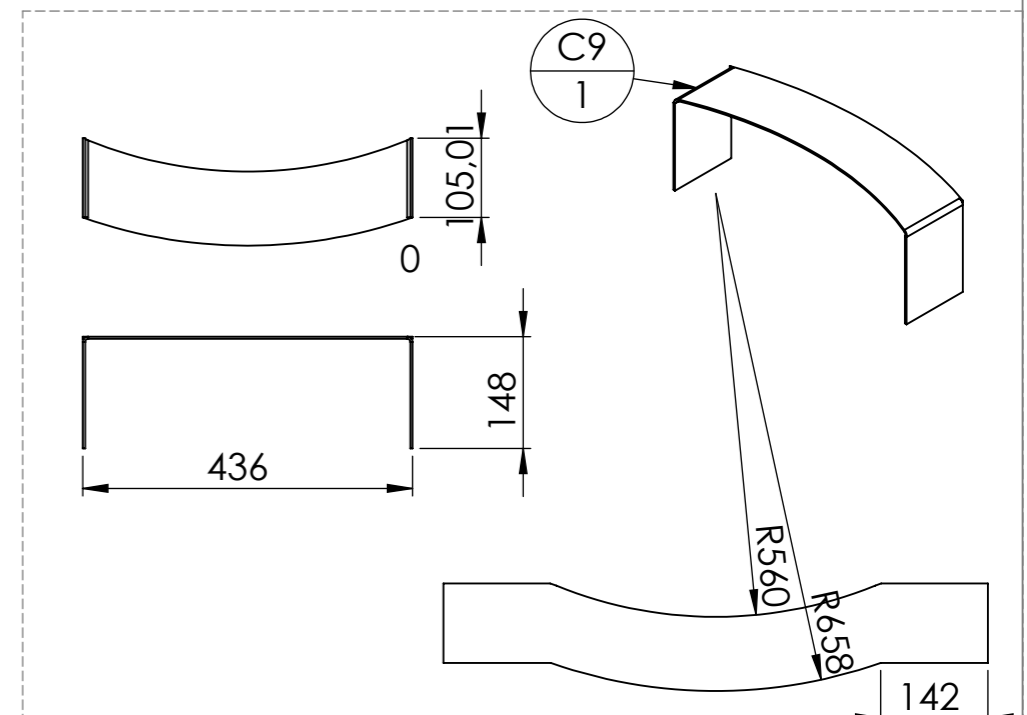

Repère	Désignation	Longueur	Qté
C9	Tôle ep3 pliée Embouchure C9		1