

Outil	Chtit-bine				
Date	18/02/2018	Version	2.0	page n° 23 / 23	
Pièce	Tournage			Qté 1	

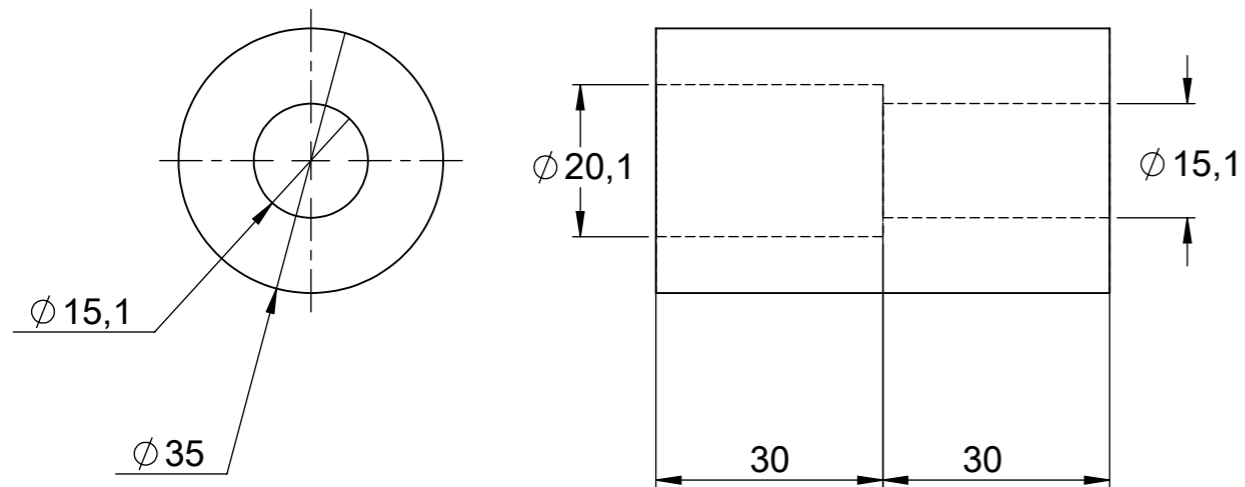

Douille  $\varnothing_{int}15$ ,  $\varnothing_{int}20$ ,  $\varnothing_{ext} 35$ ,  $l=60$   
Lien entrée boîte de vitesse <-> Axe pignon triple



Douille  $\varnothing_{int}20$ ,  $\varnothing_{ext} 35$ ,  $l=40$   
A souder sur W1

