

Outil	<b>Rouleau Faca Béton</b>				
Date	12/12/2015	Version	1.0		page n° 10 / 23
Pièce	<b>G - H - I</b>		Qté		1
N°	Désignation		Qté		
G	Machoire basse		1		

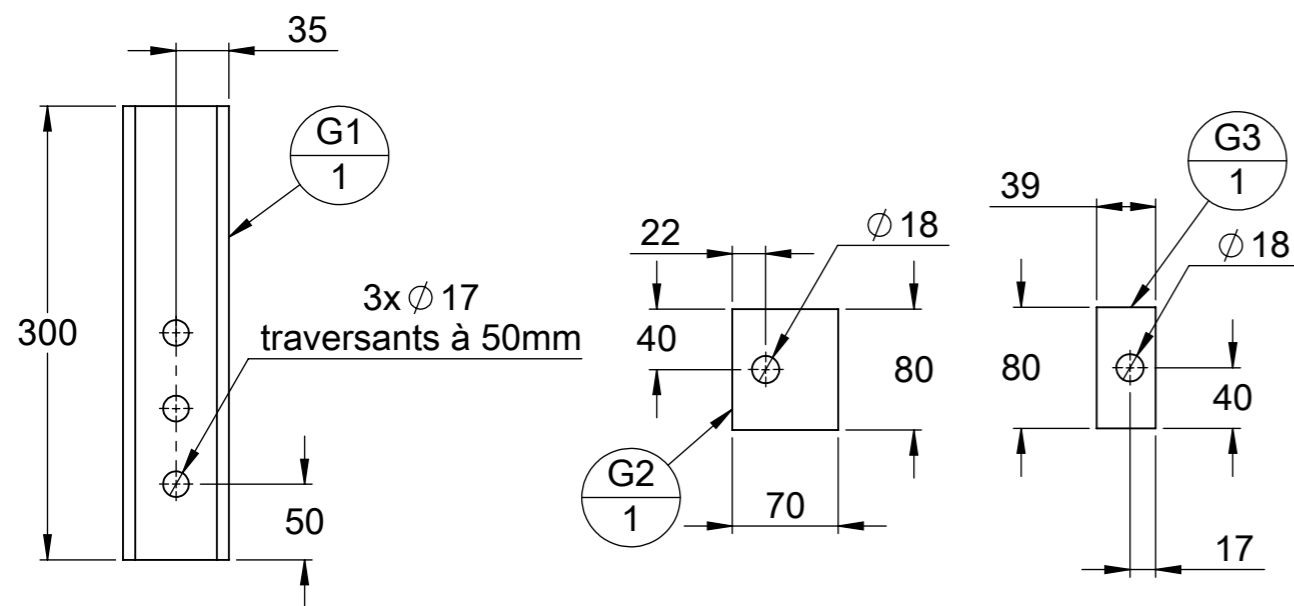

N°	Désignation	LONGUEUR	Qté
G1	tube carré 70 x 4	300	1
G2	fer plat 80 x 15	70	1
G3	fer plat 80 x 15	39	1
G4	étiré rond Ø16	80	1
G5	UPN 80 x 45	83	1
G6	Tige filetée M16	185	1

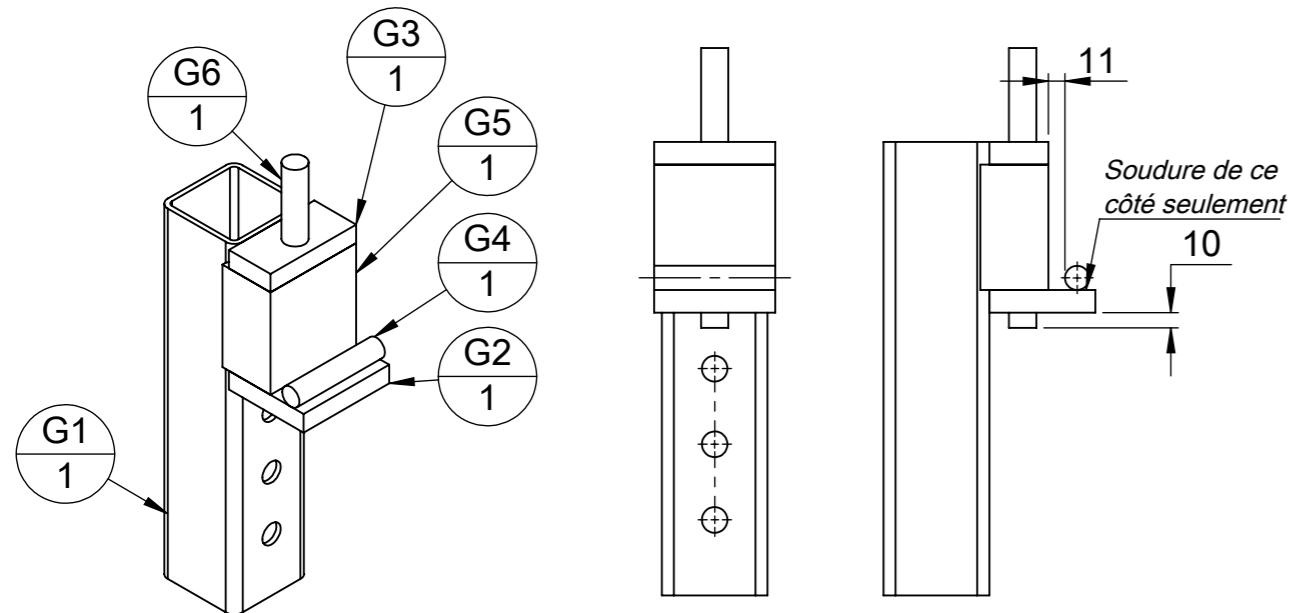
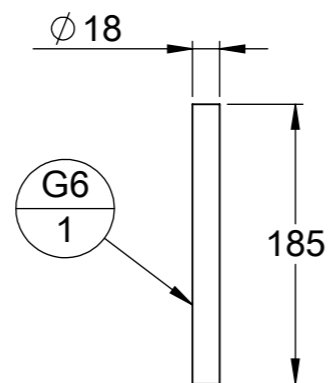

N°	Désignation	Qté
H	Machoire haute	1

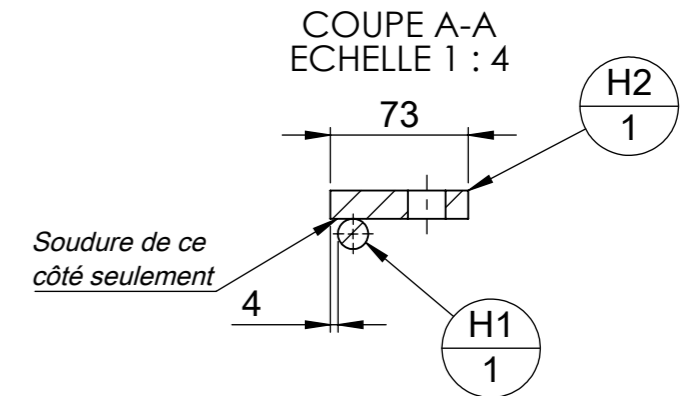
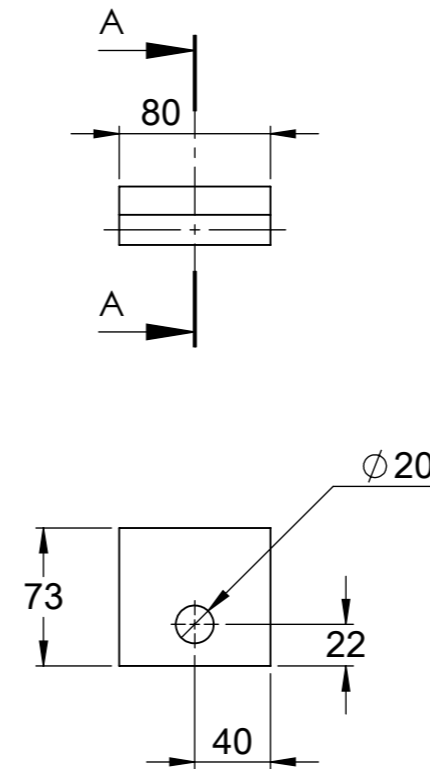
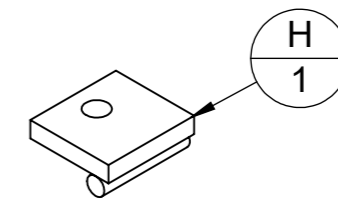

N°	Désignation	Longueur	Qté
H1	étiré rond Ø16	80	1
H2	fer plat 80 x 15	73	1

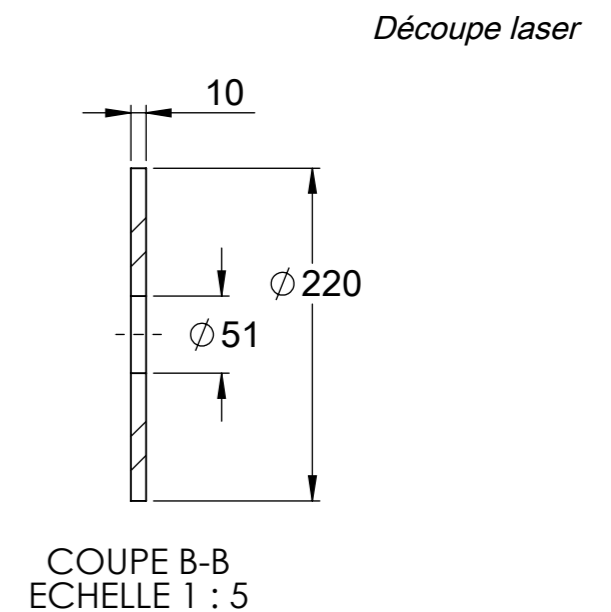
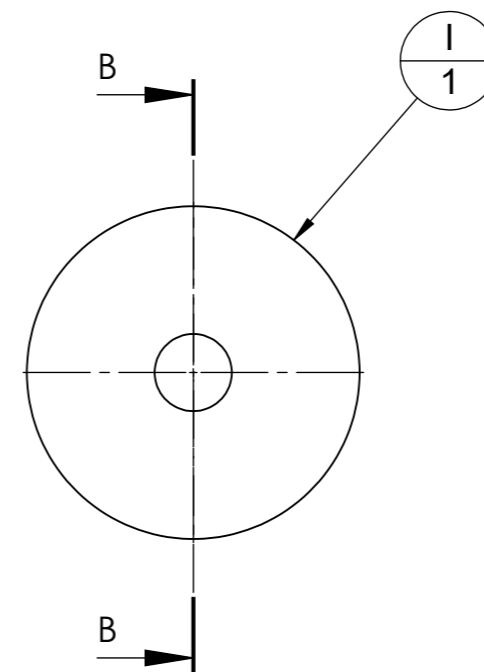

N°	Désignation	Qté
I	Rondelle rouleaux	1